



Air Preparation Products
Global Air Preparation Series

| | |
|---------------------------------|-------------------------|
| Introduction | B2-B7 |
| Particulate Filters | B8-B13 |
| Coalescing Filters | B14-B19 |
| Regulators | B20-B29 |
| Proportional Regulators | B30-B39 |
| Filter / Regulators | B40-B45 |
| Lubricators | B46-B51 |
| Combinations | B52-B55 |
| Dump Valves / Soft Start Valves | B56-B61 |
| Safety Exhaust Valve | B62-B65 |
| Accessories | B66-B76 |



| |
|------------------------|
| B |
| Global Air Preparation |
| Introduction |
| Filters |
| Coalescers |
| Regulators |
| Filter / Regulators |
| Lubricators |
| Combinations |
| Accessories and Kits |



DECLARATION OF COMPLIANCE (ROHS)

European Directive 2011/65/EU – RoHS (Restriction of certain Hazardous Substances in electrical and electronic equipment), restricts the use of the 6 substances in the manufacture of specified electrical equipment.

Lead: Product containing lead and its compound (except for applications of lead as an alloying element by weight in steel up to 0.35%, in aluminium up to 0.4% and in copper alloys up to 4% and in circuit board solder) must not exceed 0.1% by weight

Mercury: The concentration level must not exceed 0.1% by volume

Cadmium: The concentration level must not exceed 0.01% by volume

Hexavalent Chromium:
This is a corrosive protective finish used on our product line. Where this finish is utilized the Chromate solution is Hexavalent (Chrome 6) free.

Polybrominated Biphenyls (PBB):
The concentration level must not exceed 0.1% by weight. This substance is not known to be in any of our products.

Polybrominated Diphenyl Esters (PBDE):
The concentration level must not exceed 0.1% by weight. This substance is not known to be in any of our products.



Global Air Preparation products supplied by Parker Hannifin have been designed and manufactured in accordance with "sound engineering practice", as defined by Article 3 of Pressure Equipment Directive 97/23/EC.



Global Air Preparation product range is in compliance with REACH to ensure continued compliance additions to the list of SVHC (Substance of Very High Concern) are reviewed periodically.

Global Air Preparation product range has been third party Shock & Vibration tested independently in accordance to EN 61373 : 1999, Category 2



Following Ignition Hazard Assessments performed on the non-electrical Global Air Preparation products they are in accordance with the requirements of EN 13463-1:2009, it was considered that the equipment does not contain its own source of ignition, and therefore is not within the scope of directive 94/9/EC.

The products can be used in a Group II Category 2 environment assuming that the ATEX Directive and the following conditions are complied with:

- Installation and maintenance of the product must be undertaken by qualified personnel.
- Do not mount the products in an area where impact may occur.
- Filters must be used to limit the introduction of particles and to capture particles generated in service.
- Supply air quality must be within ISO 8573-1:2010 Class 1.4.2.
- Maximum working temperature to be as stated on product label.
- WARNING – pulsating pressure and/or a closed circuit can generate heat.
- Deposits of dust on the product must not exceed 5mm thickness.
Refer to technical file for surface areas of plastics. The unit must be earthed via the compressed air supply line.
- The unit must not come into contact with liquid solvents, acids or alkalis
Refer to technical file for chemicals known to be incompatible. Product cleaning must be undertaken using a method complying with the specifications of the ATEX zone, preferably by using mild soap and water or antistatic products.
- Regulators, Filter Regulators:
Do not use Regulators or Filter Regulators within systems that can create vibration within the Regulator / Filter Regulator unit.
- Solenoid Operated Valves:
Are suitable for use in an ATEX environment, (Group II Category 2) providing ATEX approved solenoids are fitted.
- Technical file available on request.



Global Air Preparation product range has been designed and tested in accordance with ISO flow testing, envelope integrity, and catalog data presented.

- Filters – ISO 5782-1 & ISO 5782-2: 1997
- Regulators- ISO 6953-1 & ISO 6953-2: 2000
- Lubricators- ISO 6301-1 & ISO 6301-2: 2009





Parker Global Air Preparation System

**Global.
Modular.**



*Performance you need,
wherever you need it.*

Full featured particulate and coalescing filters, regulators, filter/regulators, and lubricators are available with a wide range of standard options to meet air preparation needs.

The comprehensive Global Air Preparation System is available in three body sizes with either BSPP, BSPT, or NPT to accommodate thread type requirements.

Individual units can easily be assembled into various combinations, utilizing patented modular lightweight body connectors.

www.parker.com/globalfrl

B

Global Air Preparation

Introduction

Filters

Coalescers

Regulators

Filter /
Regulators

Lubricators

Combinations

Accessories
and Kits



A completely modular air preparation system

B

Global Air Preparation

Introduction

Filters

Coalescers

Regulators

Filter / Regulators

Lubricators

Combinations

Accessories and Kits

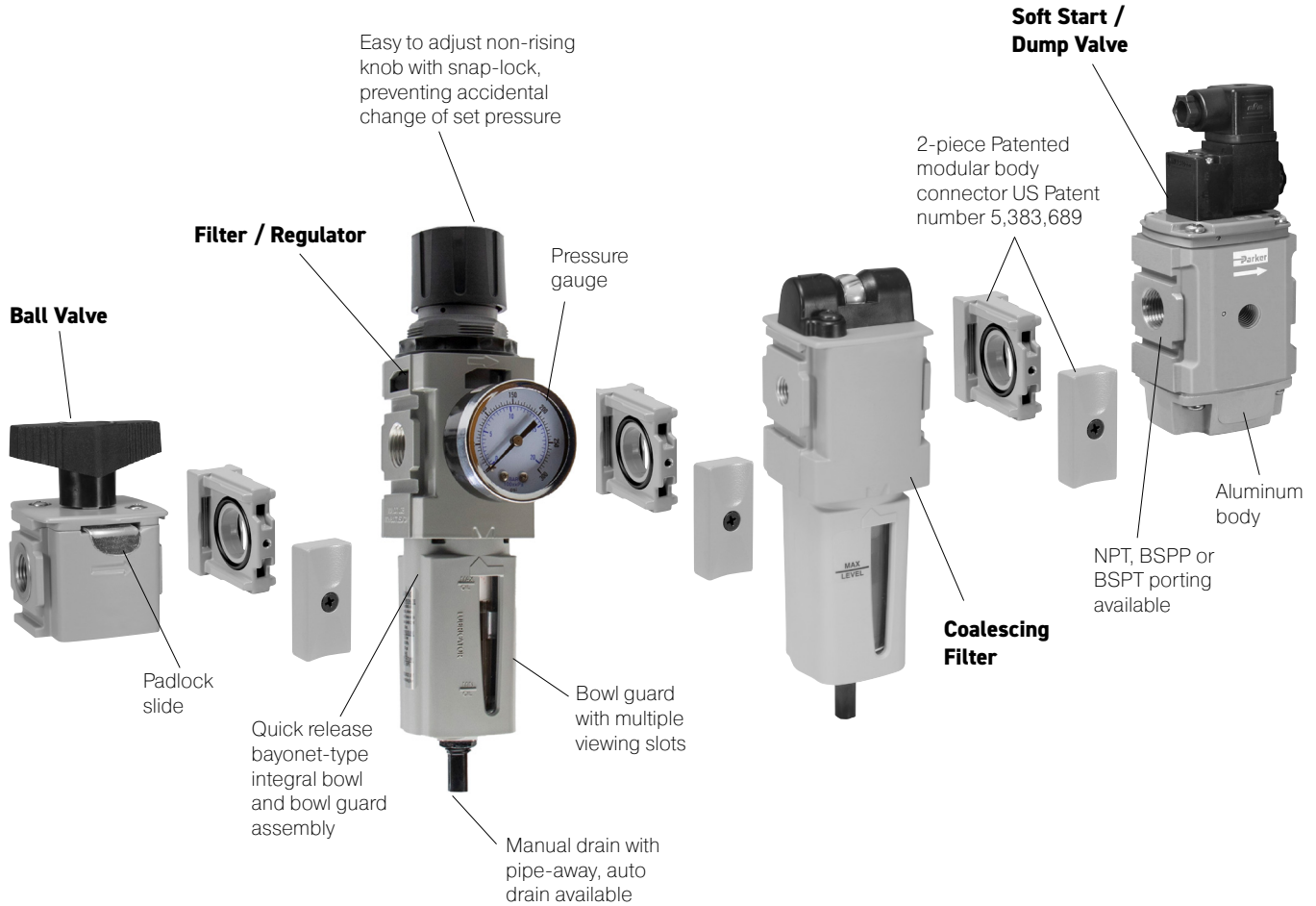

Comprehensive Offering



P31 Mini Series
1/4" ports
40mm body width



P32 Compact Series
1/4", 3/8" and 1/2"
60mm body width



P33 Standard Series
1/2" and 3/4"
73mm body width



Filters

- 5 μ particulate, 1.0 μ and 0.01 μ coalescing, and adsorber available as standard
- Transparent or metal bowl with manual or auto float drains standard



Regulators

- Available as stand alone, common port and electronic proportional
- Both relieving and non-relieving versions available



Filter / Regulators

- Compact design for space savings
- Available with all the same standard options as the filters and regulators



Lubricators

- Proportional oil delivery over a wide range of air flows
- Fill under pressure



Combinations

- Compact design for space savings
- Easily assembled
- Many configurations available

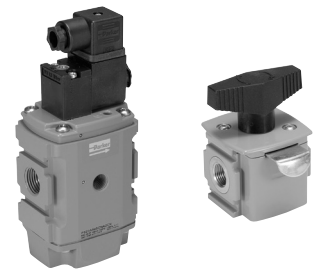

Accessories

- Solenoid operated soft start, quick dump, and soft start/quick dump valves
- Manifold blocks
- Ball style lockout / shutoff valve
- Repair kits, gauges, etc.

B

Global Air Preparation

Introduction

Filters

Coalescers

Regulators

Filter / Regulators

Lubricators

Combinations

Accessories and Kits



Air Preparation

P31 Mini Series

40mm body width
1/4" Ported

| Flows up to: | scfm (dm ³ /s, ANR) | |
|------------------|--------------------------------|-------|
| Filter | 25 | (12) |
| Coalescer | 7.5 | (3.6) |
| Regulator | 73 | (34) |
| Filter/Regulator | 22 | (10) |
| Lubricator | 52 | (25) |

Features:

- Space saving integral gauge
- Manifold style regulators available
- OSHA compliant shut-off valves
- Soft-Start & Quick Dump valves
- Electronic Proportional Regulator



P32 Compact Series

60mm body width
1/4", 3/8", & 1/2" Ported

| Flows up to: | scfm (dm ³ /s, ANR) | |
|------------------|--------------------------------|------|
| Filter | 82 | (39) |
| Coalescer | 36 | (17) |
| Regulator | 201 | (94) |
| Filter/Regulator | 178 | (84) |
| Lubricator | 90 | (42) |

Features:

- Manifold style regulators available
- OSHA Compliant shut-off valves
- Soft-Start & Quick Dump valves
- Electronic Proportional Regulator



P33 Standard Series

73mm body width
1/2" & 3/4" Ported

| Flows up to: | scfm (dm ³ /s, ANR) | |
|------------------|--------------------------------|-------|
| Filter | 85 | (40) |
| Coalescer | 72 | (34) |
| Regulator | 233 | (111) |
| Filter/Regulator | 230 | (108) |
| Lubricator | 150 | (71) |

Features:

- OSHA Compliant shut-off valves
- Soft-Start & Quick Dump valves (Utilizes P32 size only)
- Electronic proportional regulator (Utilizes P32 size only)



| | |
|----------------------|------------------------|
| B | Global Air Preparation |
| | Introduction |
| Filters | Coalescers |
| Regulators | Filter / Regulators |
| Lubricators | Combinations |
| Accessories and Kits | |



Complete Pneumatic System

Common Port Manifold Regulators

- Multiple output pressures (P2, P3, P4, etc.) with common inlet (P1)
- Available in two sizes P31 and P32
- Balanced valve design for accurate pressure regulation
- Outlet pressure ports in front and rear of unit.
- Multiple spring ranges available



Electronic Proportional Regulator

- Electro-Pneumatic regulator
- Integrated systems control
- Accurate output pressure
- Micro parameter settings
- Selectable I/O parameters
- Quick, full flow exhaust
- LED display indicates output pressure
- No air consumption in steady state
- Multiple mounting options
- Protection to IP65



P31P Mini Series



P32P Compact Series

Optional Tamperproof Kits

- Hinged black part clamps over control knob and is locked in place after sliding yellow cover over it
- Other allows for removable lockout/tagout tamperproofing
 - Four pad lock location holes tagout
 - Hinged locking clamp secures over existing knob via yellow cover which is slid over into place



Mini Particulate Filters

P31 Particulate Filter - Mini

- Integral 1/4" ports (NPT, BSPP & BSPT)
- High efficiency 5 micron element as standard
- Excellent water removal efficiency
- Robust but lightweight aluminum construction
- One hand operation for easy element cartridge removal
- Positive bayonet latch to ensure correct & safe fitting

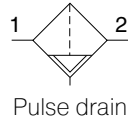
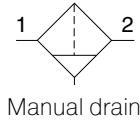

Operating information

| | |
|------------------------|--------------------------------------|
| Supply pressure (max): | |
| Plastic bowl | 150 psig (10 bar) |
| Metal bowl | 250 psig (17 bar) |
| Operating temperature: | |
| Plastic bowl | 14°F to 125°F (-10°C to 52°C) |
| Metal bowl | 14°F to 150°F (-10°C to 65.5°C) |
| Standard filtration: | 5 micron |
| Flow capacity*: | 25 scfm (12 dm ³ /s, ANR) |
| Useful retention†: | 0.4 US oz. (12 cm ³) |
| Weight: | 0.24 lb (0.11 kg) |

* Inlet pressure 91.3 psig (6.3 bar). Pressure drop 4.9 psig (0.34 bar).
† Useful retention refers to volume below the quiet zone baffle.

Air quality:
Within ISO 8573-1: 1991 Class 3 (Particulates)
Within ISO 8573-1: 2001 Class 6 (Particulates)

| Port Size | Description † | Part Number |
|-----------|--------------------------|--------------------|
| 1/4" | Poly Bowl, Manual Drain | P31FB92EGMN |
| 1/4" | Poly Bowl, Pulse Drain | P31FB92EGBN |
| 1/4" | Metal Bowl, Manual Drain | P31FB92EMMN |
| 1/4" | Metal Bowl, Pulse Drain | P31FB92EMBN |

† For polycarbonate bowl, see caution in Engineering Section A.

Ordering information:

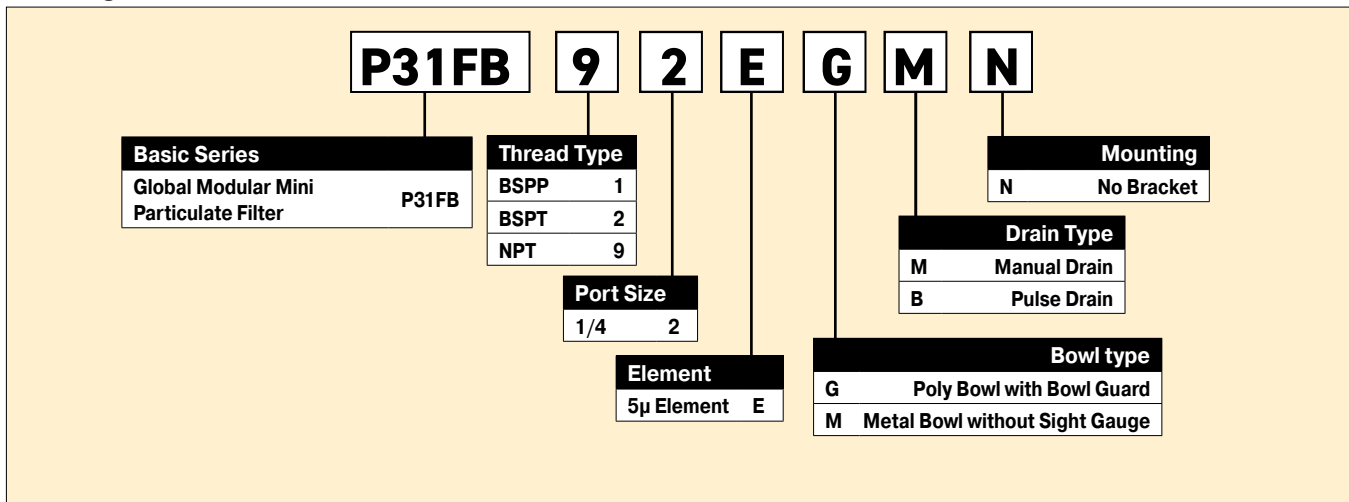

Most popular.

B
Global Air Preparation

Introduction

Filters

Coalescers

Regulators

Filter / Regulators

Lubricators

Combinations

Accessories and Kits



Mini Particulate Filters

Material Specifications

| | |
|-----------------------------|---------------|
| Body | Aluminum |
| Body cap | ABS |
| Plastic bowl | Polycarbonate |
| Metal bowl | Aluminum |
| Bowl guard | Nylon |
| Element retainer | Acetal |
| Baffle | Acetal |
| Filter element polyethylene | Sintered |
| Seals | Nitrile |

Repair and Service Kits

| | |
|--|-------------------|
| Plastic bowl / bowl guard, manual drain | P31KB00BGM |
| Metal bowl / w/o sight gauge, manual drain | P31KB00BMM |
| Plastic bowl / bowl guard, pulse drain | P31KB00BGB |
| Metal bowl / w/o sight gauge, pulse drain | P31KB00BMB |
| 5 μ particle filter element | P31KA00ESE |
| C-bracket (fits to body) | P31KA00MW |
| T-bracket with body connector | P31KA00MT |
| Body connector | P31KA00CB |

Flow Charts

P31FB 1/4" Filter

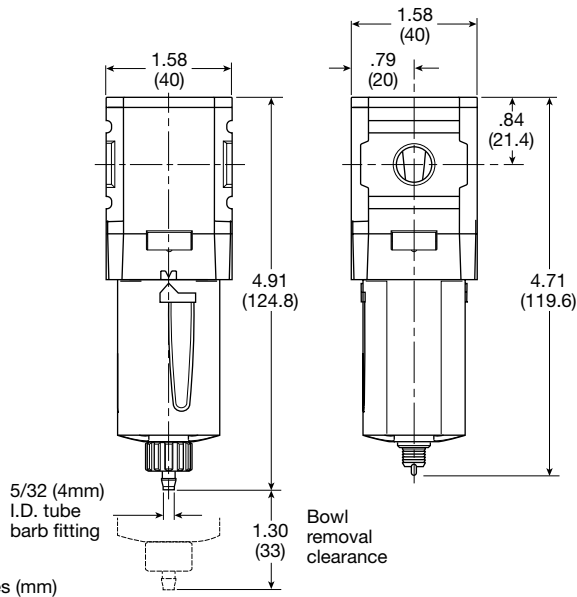
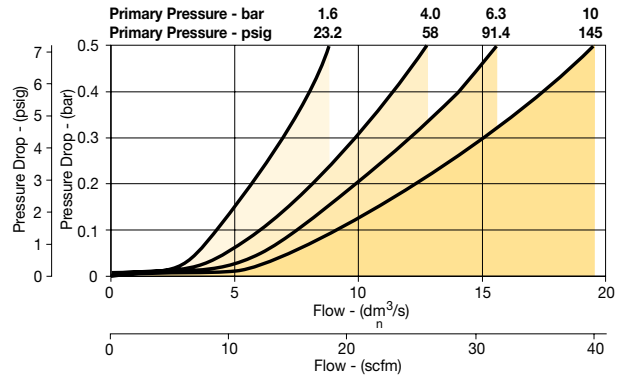

Manual Drain

Pulse Drain



Compact Particulate Filters

P32 Particulate Filter - Compact

- Integral 1/4", 3/8" or 1/2" ports (NPT, BSPP & BSPT)
- High efficiency 5 micron element as standard
- Excellent water removal efficiency
- Robust but lightweight aluminum construction
- Positive bayonet latch to ensure correct & safe fitting

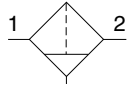

Manual drain

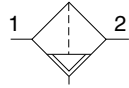

Auto drain

| Port Size | Description † | Part Number |
|-----------|--------------------------|--------------------|
| 1/4" | Poly Bowl, Manual Drain | P32FB92EGMN |
| 1/4" | Poly Bowl, Auto Drain | P32FB92EGAN |
| 1/4" | Metal Bowl, Manual Drain | P32FB92ESMN |
| 1/4" | Metal Bowl, Auto Drain | P32FB92ESAN |
| 3/8" | Poly Bowl, Manual Drain | P32FB93EGMN |
| 3/8" | Poly Bowl, Auto Drain | P32FB93EGAN |
| 3/8" | Metal Bowl, Manual Drain | P32FB93ESMN |
| 3/8" | Metal Bowl, Auto Drain | P32FB93ESAN |
| 1/2" | Poly Bowl, Manual Drain | P32FB94EGMN |
| 1/2" | Poly Bowl, Auto Drain | P32FB94EGAN |
| 1/2" | Metal Bowl, Manual Drain | P32FB94ESMN |
| 1/2" | Metal Bowl, Auto Drain | P32FB94ESAN |

† For polycarbonate bowl, see caution in Engineering Section A.

Operating information

| | |
|------------------------|--------------------------------------|
| Supply pressure (max): | |
| Plastic bowl | 150 psig (10 bar) |
| Metal bowl | 250 psig (17 bar) |
| Operating temperature: | |
| Plastic bowl | -13°F to 125°F (-25°C to 52°C) |
| Metal bowl | -13°F to 150°F (-25°C to 65.5°C) |
| Standard filtration: | 5 micron |
| Flow capacity*: | |
| 1/4" | 50 scfm (24 dm ³ /s, ANR) |
| 3/8" | 78 scfm (37 dm ³ /s, ANR) |
| 1/2" | 82 scfm (39 dm ³ /s, ANR) |
| Useful retention†: | 1.7 US oz. (51 cm ³) |
| Weight: | 0.62 lb (0.28 kg) |

* Inlet pressure 91.3 psig (6.3 bar). Pressure drop 4.9 psig (0.34 bar).
† Useful retention refers to volume below the quiet zone baffle.

Air quality:
Within ISO 8573-1: 1991 Class 3 (Particulates)
Within ISO 8573-1: 2001 Class 6 (Particulates)

Ordering Information:

P32FB 9 2 E G M N

| | | | | | | |
|---|---|---|--------------------------------|---------------------------------|---|--|
| Basic Series Global Modular Compact Particulate Filter P32FB | Thread Type BSPP 1 BSPT 2 NPT 9 | Port Size 1/4 2 3/8 3 1/2 4 | Element 5µ Element E | Mounting N No Bracket | Drain Type M Manual Drain A Auto Drain | Bowl Type G Poly Bowl with Bowl Guard M Metal Bowl without Sight Gauge S Metal Bowl with Sight Gauge |
|---|---|---|--------------------------------|---------------------------------|---|--|

Most popular.



Compact Particulate Filters

Material Specifications

| | |
|-----------------------------|---------------|
| Body | Aluminum |
| Body cap | ABS |
| Plastic bowl | Polycarbonate |
| Metal bowl | Aluminum |
| Bowl guard | Nylon |
| Deflector | Polypropylene |
| Element retainer / Baffle | Acetal |
| Filter element polyethylene | Sintered |
| Seals | Nitrile |
| Sight gauge | Nylon |

Repair and Service Kits

| | |
|---|-------------------|
| Plastic bowl / bowl guard, manual drain | P32KB00BGM |
| Metal bowl / sight gauge, manual drain | P32KB00BSM |
| Auto drain | P32KA00DA |
| 5 μ particle filter element | P32KA00ESE |
| L-bracket (fits to body) | P32KA00ML |
| T-bracket (fits to body connector) | P32KA00MB |
| T-bracket with body connector | P32KA00MT |
| Body connector | P32KA00CB |

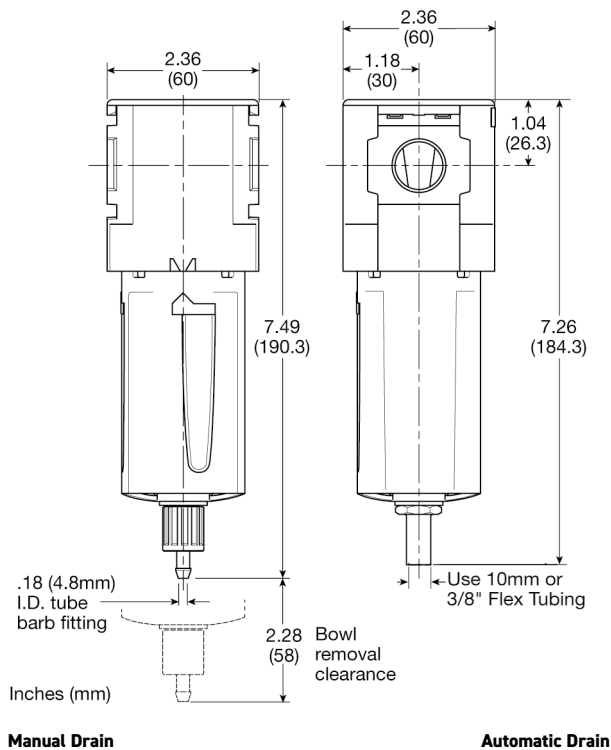

Air Preparation Products Global Air Preparation

Flow Charts

P32FB 1/4" Filter

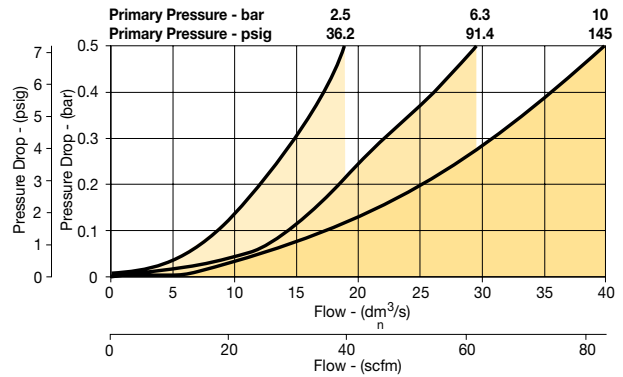

P32FB 3/8" Filter

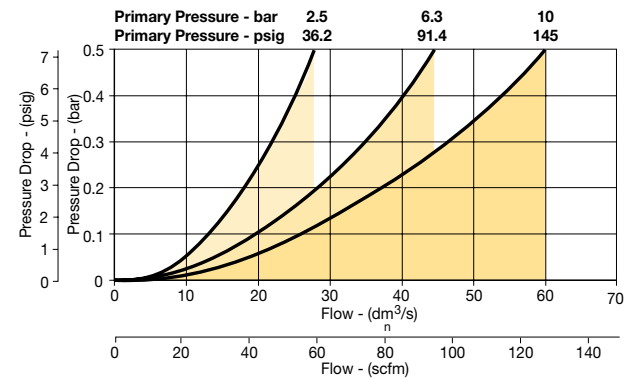

P32FB 1/2" Filter

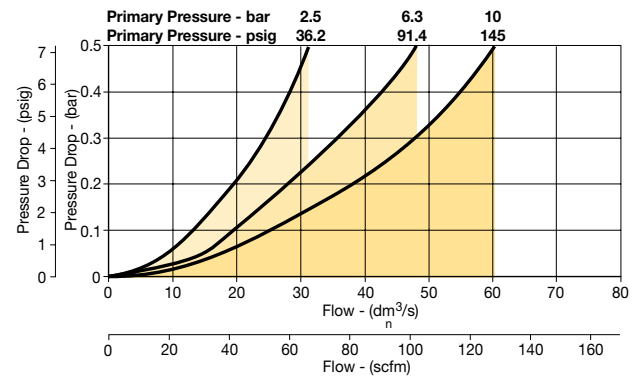

B

Global Air Preparation

Introduction

Filters

Coalescers

Regulators

Filter / Regulators

Lubricators

Combinations

Accessories and Kits



P33 Particulate Filter - Standard

- Integral 1/2" or 3/4" ports (NPT, BSPP & BSPT)
- High efficiency 5 micron element as standard
- Excellent water removal efficiency
- Robust but lightweight aluminum construction
- Positive bayonet latch to ensure correct & safe fitting

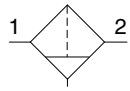

Manual drain

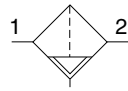

Auto drain

| Port Size | Description † | Part Number |
|-----------|--------------------------|--------------------|
| 1/2" | Poly Bowl, Manual Drain | P33FA94EGMN |
| 1/2" | Poly Bowl, Auto Drain | P33FA94EGAN |
| 1/2" | Metal Bowl, Manual Drain | P33FA94ESMN |
| 1/2" | Metal Bowl, Auto Drain | P33FA94ESAN |
| 3/4" | Poly Bowl, Manual Drain | P33FA96EGMN |
| 3/4" | Poly Bowl, Auto Drain | P33FA96EGAN |
| 3/4" | Metal Bowl, Manual Drain | P33FA96ESMN |
| 3/4" | Metal Bowl, Auto Drain | P33FA96ESAN |

† For polycarbonate bowl, see caution in Engineering Section A.

Operating information

| | |
|--|----------------------------------|
| Supply pressure (max): | |
| Plastic bowl | 150 psig (10 bar) |
| Metal bowl | 250 psig (17 bar) |
| Operating temperature: | |
| Plastic bowl | -13°F to 125°F (-25°C to 52°C) |
| Metal bowl | -13°F to 150°F (-25°C to 65.5°C) |
| Standard filtration: | 5 micron |
| Flow capacity*: | 1/2 85 scfm (40 dm³/s, ANR) |
| | 3/4 102 scfm (48 dm³/s, ANR) |
| Useful retention†: | 2.8 US oz. (85 cm³) |
| Weight: | 1.01 lb (0.46 kg) |
| * Inlet pressure 91.3 psig (6.3 bar). Pressure drop 4.9 psig (0.34 bar). | |
| † Useful retention refers to volume below the quiet zone baffle. | |

Air quality:
Within ISO 8573-1: 1991 Class 3 (Particulates)
Within ISO 8573-1: 2001 Class 6 (Particulates)

Ordering Information:

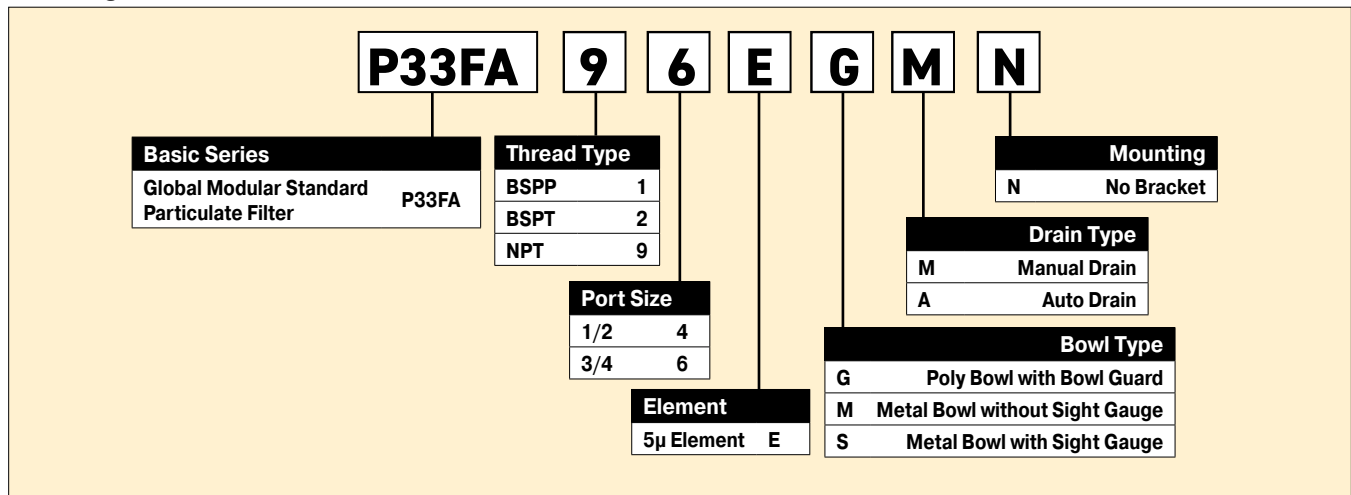

Most popular.



Standard Particulate Filters

Material Specifications

| | |
|-----------------------------|---------------|
| Body | Aluminum |
| Bowl cap | ABS |
| Plastic bowl | Polycarbonate |
| Metal bowl | Aluminum |
| Bowl guard | Nylon |
| Deflector | Polypropylene |
| Element retainer / Baffle | Acetal |
| Filter element polyethylene | Sintered |
| Seals | Nitrile |
| Sight gauge | Nylon |

Repair and Service Kits

| | |
|---|-------------------|
| Plastic bowl / bowl guard, manual drain | P33KA00BGM |
| Metal bowl / sight gauge, manual drain | P33KA00BSM |
| Auto drain | P32KA00DA |
| 5 μ particle filter element | P33KA00ESE |
| L-bracket (fits to body) | P33KA00ML |
| T-bracket (fits to body connector) | P32KA00MB |
| T-bracket with body connector | P32KA00MT |
| Body connector | P32KA00CB |

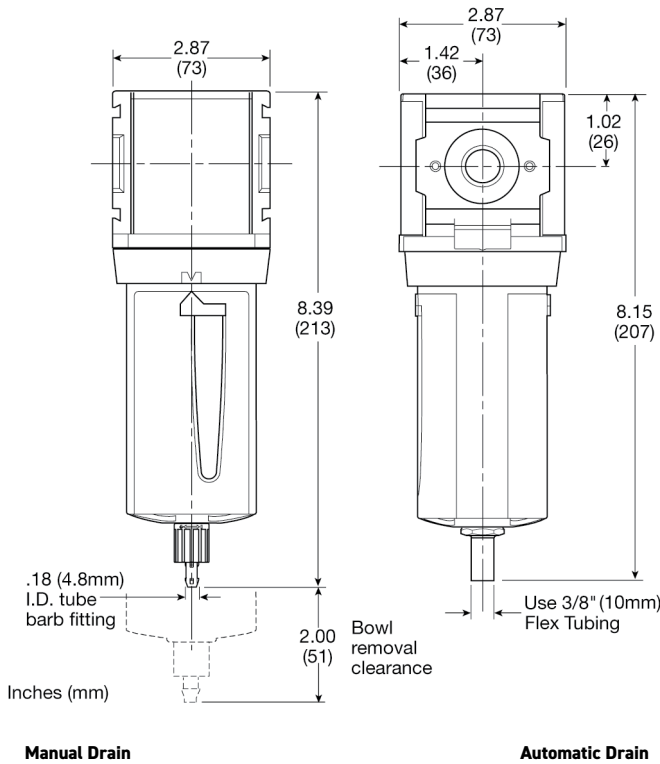

Air Preparation Products Global Air Preparation

Flow Charts

P33FA 1/2" Filter

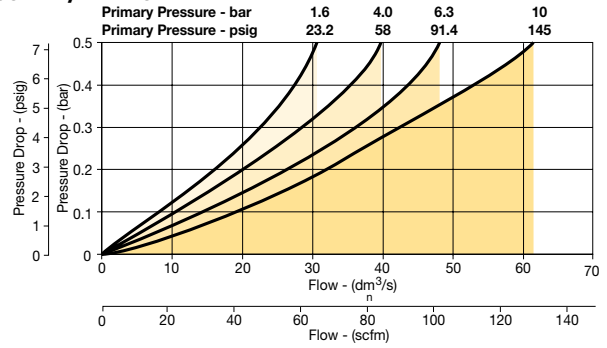

P33FA 3/4" Filter

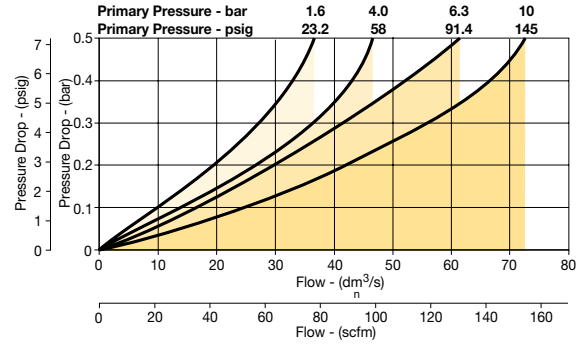

P31 Coalescing and Adsorber Filters - Mini

- Integral 1/4" ports (NPT, BSPP & BSPT)
- Removes liquid aerosols and sub micron particles
- Oil free air for critical applications, such as air gauging, pneumatic instrumentation and control
- Positive bayonet latch to ensure correct and safe fitting
- Adsorbing activated carbon element removes oil vapors and most hydrocarbons



Note: To optimize the life of coalescing element, it is advisable to install a P31F pre-filter with a 5 micron element upstream of the coalescing filter.

To optimize the life of an Adsorber it is advisable to install a P31 Coalescing Filter upstream of the Adsorber. Adsorber element should be replaced approximately every 1000 hours of service.

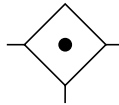

| Port Size | Description * | Element | Part Number |
|-----------|--------------------------|-------------|--------------------|
| 1/4" | Poly Bowl, Manual Drain | 0.01 micron | P31FB92DGMN |
| 1/4" | Poly Bowl, Pulse Drain | 0.01 micron | P31FB92DGBN |
| 1/4" | Metal Bowl, Manual Drain | 0.01 micron | P31FB92DMMN |
| 1/4" | Metal Bowl, Pulse Drain | 0.01 micron | P31FB92DMBN |

* For polycarbonate bowl, see caution in Engineering Section A.

Operating information

| | |
|---------------------------------|---|
| Supply pressure (max): | |
| Poly bowl | 150 psig (10 bar) |
| Metal bowl w/ DPI | 150 psig (10 bar) |
| Metal bowl w/o DPI | 250 psig (17 bar) |
| Operating temperature: | |
| Plastic bowl | 14°F to 125°F (-10°C to 52°C) |
| Metal bowl | 14°F to 150°F (-10°C to 65.5°C) |
| Standard filtration: | 1.0 and 0.01 micron |
| Adsorber | Max. oil carryover (ppm w/w) 0.003 @ 70°F (21°C) |
| Flow capacity*: | |
| 1.0 micron coalescing | 12 scfm (5.5 dm ³ /s, ANR) |
| 0.01 micron coalescing | 7.5 scfm (3.6 dm ³ /s, ANR) |
| Activated carbon adsorber | 12.7 scfm (6 dm ³ /s, ANR) |
| Useful retention [†] : | 0.4 US oz. (12 cm ³) |
| Weight: | 0.24 lb (0.11 kg) |

* Inlet pressure 91.3 psig (6.3 bar). Pressure drop 3 psig (0.2 bar), saturated element.

[†] Useful retention refers to volume below the quiet zone baffle.

Ordering Information:

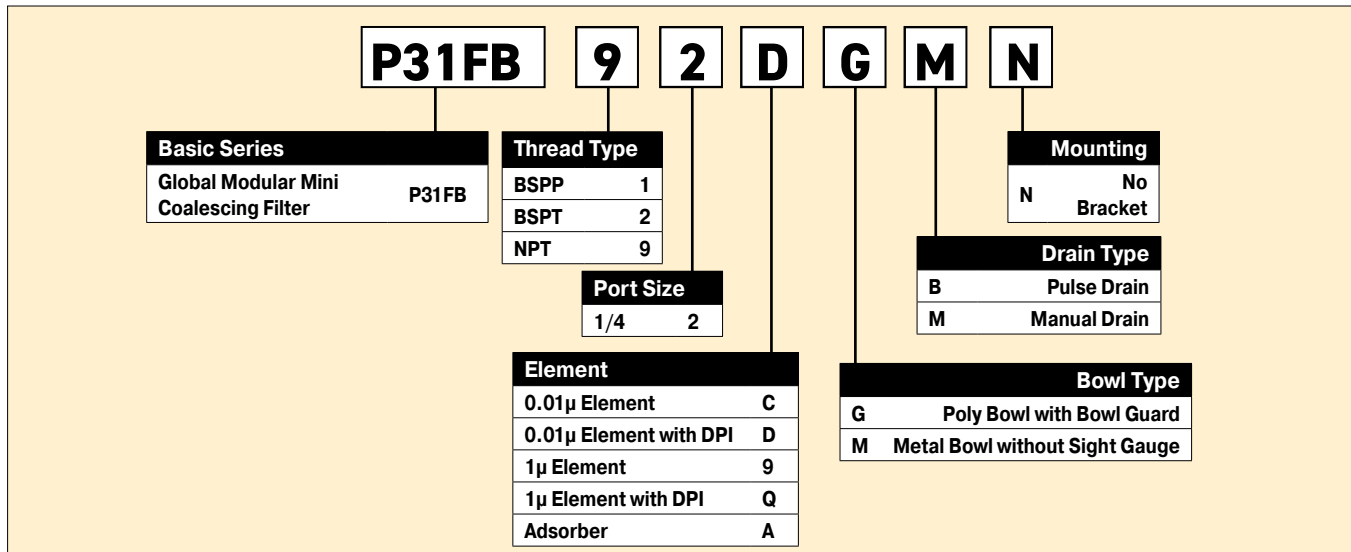

Most popular.

Global Air Preparation

Introduction

Filters

Coalescers

Regulators

Filter / Regulators

Lubricators

Combinations

Accessories and Kits



Mini Coalescing and Adsorber Filters

Air Preparation Products Global Air Preparation

Material Specifications

| | |
|------------------|--------------------|
| Body | Aluminum |
| Body cap | ABS |
| Plastic bowl | Polycarbonate |
| Metal bowl | Aluminum |
| Filter element | Borosilicate cloth |
| Adsorber element | Activated carbon |
| Seals | Nitrile |

Repair and Service Kits

| | |
|---|-------------------|
| Plastic bowl / bowl guard, manual drain | P31KB00BGM |
| Metal bowl / w/o sight gauge, manual drain | P31KB00BMM |
| Plastic bowl / bowl guard, pulse drain | P31KB00BGB |
| Metal bowl / w/o sight gauge, pulse drain | P31KB00BMB |
| 1µ coalescing filter element | P31KA00ES9 |
| 0.01µ coalescing filter element | P31KA00ESC |
| Activated carbon adsorber filter element | P31KA00ESA |
| C-bracket (fits to body) | P31KA00MW |
| T-bracket with body connector | P31KA00MT |
| Body connector | P31KA00CB |
| Differential pressure indicator (replacement) | P31KB00RQ |

Flow Charts

P31FB - 1.0 micron flow

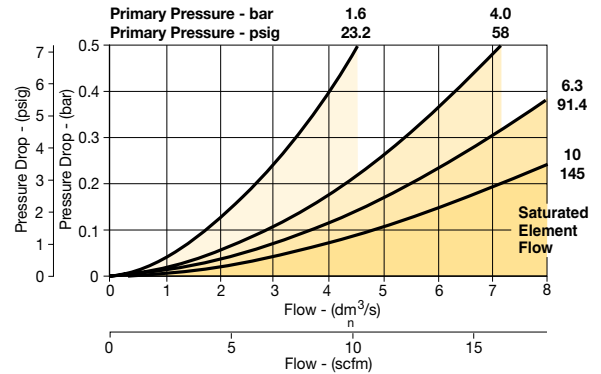

P31FB - 0.01 micron flow

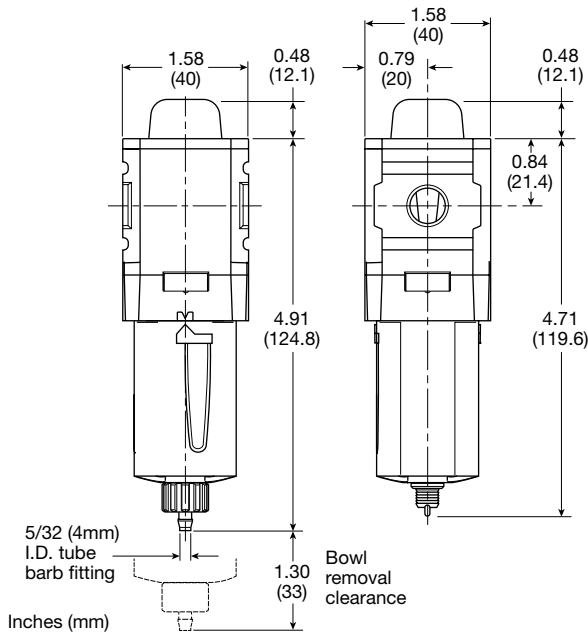
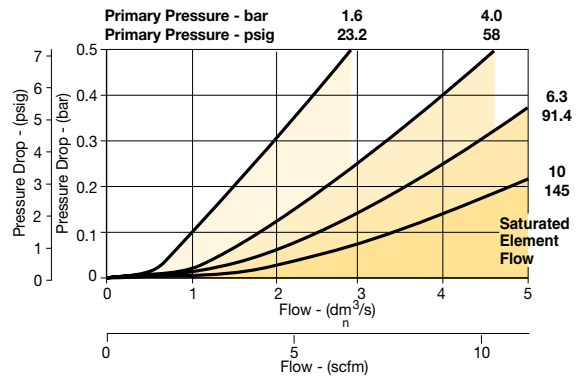

Manual Drain

Pulse Drain



P32 Coalescing and Adsorber Filters - Compact

- Integral 1/4", 3/8" or 1/2" ports (NPT, BSPP & BSPT)
- Removes liquid aerosols and sub micron particles
- Oil free air for critical applications, such as air gauging, pneumatic instrumentation and control
- Differential Pressure Indicator (DPI) standard on Coalescing Filters
- Positive bayonet latch to ensure correct & safe fitting
- Adsorbing activated carbon element removes oil vapors and most hydrocarbons

Note: To optimize the life of coalescing element, it is advisable to install a P32F pre-filter with a 5 micron element upstream of the coalescing filter.
To optimize the life of an Adsorber it is advisable to install a P32 Coalescing Filter upstream of the Adsorber. Adsorber element should be replaced approximately every 1000 hours of service.

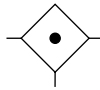

| Port Size | Description † | Element | Part Number |
|-----------|--------------------------|-------------|--------------------|
| 1/4" | Poly Bowl, Manual Drain | 0.01 micron | P32FB92DGMN |
| 1/4" | Poly Bowl, Auto Drain | 0.01 micron | P32FB92DGAN |
| 1/4" | Metal Bowl, Manual Drain | 0.01 micron | P32FB92DSMN |
| 1/4" | Metal Bowl, Auto Drain | 0.01 micron | P32FB92DSAN |
| 3/8" | Poly Bowl, Manual Drain | 0.01 micron | P32FB93DGMN |
| 3/8" | Poly Bowl, Auto Drain | 0.01 micron | P32FB93DGAN |
| 3/8" | Metal Bowl, Manual Drain | 0.01 micron | P32FB93DSMN |
| 3/8" | Metal Bowl, Auto Drain | 0.01 micron | P32FB93DSAN |
| 1/2" | Poly Bowl, Manual Drain | 0.01 micron | P32FB94DGMN |
| 1/2" | Poly Bowl, Auto Drain | 0.01 micron | P32FB94DGAN |
| 1/2" | Metal Bowl, Manual Drain | 0.01 micron | P32FB94DSMN |
| 1/2" | Metal Bowl, Auto Drain | 0.01 micron | P32FB94DSAN |

† For polycarbonate bowl, see caution in Engineering Section A.

Operating information

| | |
|---------------------------|---|
| Supply pressure (max): | |
| Poly bowl | 150 psig (10 bar) |
| Metal bowl w/ DPI | 150 psig (10 bar) |
| Metal bowl w/o DPI | 250 psig (17 bar) |
| Operating temperature: | |
| Plastic bowl | -13°F to 125°F (-25°C to 52°C) |
| Metal bowl | -13°F to 150°F (-25°C to 65.5°C) |
| Standard filtration: | 1.0 and 0.01 micron |
| Adsorber | Max. oil carryover (ppm w/w) 0.003 @ 70°F (21°C) |
| Flow capacity*: | |
| 1.0 micron coalescing | 53 scfm (25 dm³/s, ANR) |
| 0.01 micron coalescing | 36 scfm (17 dm³/s, ANR) |
| Activated carbon adsorber | 85 scfm (40 dm³/s, ANR) |
| Useful retention†: | 1.7 US oz. (51 cm³) |
| Weight: | 0.71 lb (0.32 kg) |

* Inlet pressure 91.3 psig (6.3 bar). Pressure drop 3 psig (0.2 bar), saturated element.

† Useful retention refers to volume below the quiet zone baffle.

Ordering Information:

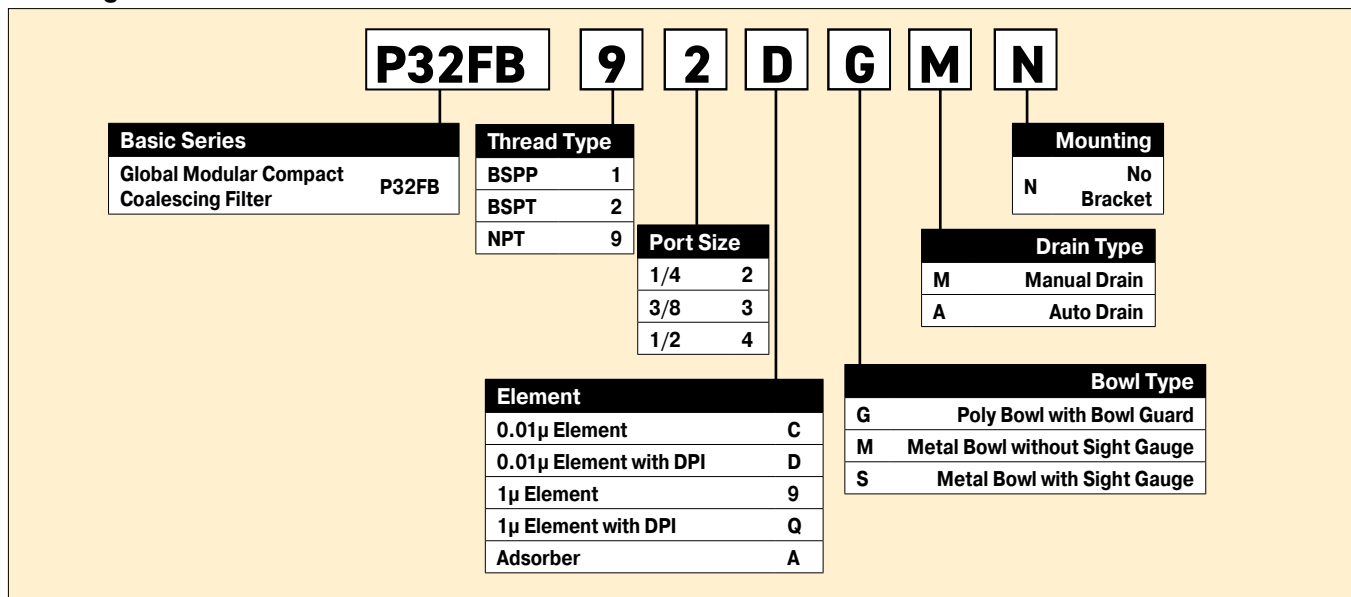

Most popular.



Compact Coalescing and Adsorber Filters

Air Preparation Products Global Air Preparation

Material Specifications

| | |
|----------------|--------------------|
| Body | Aluminum |
| Body cap | ABS |
| Plastic bowl | Polycarbonate |
| Metal bowl | Aluminum |
| Filter element | Borosilicate cloth |
| Adsorber | Activated carbon |
| Seals | Nitrile |
| Sight gauge | Nylon |

Repair and Service Kits

| | |
|---|-------------------|
| Plastic bowl / bowl guard, manual drain | P32KB00BGM |
| Metal bowl / sight gauge, manual drain | P32KB00BSM |
| Auto drain | P32KA00DA |
| 1 μ coalescing filter element | P32KA00ES9 |
| 0.01 μ coalescing filter element | P32KA00ESC |
| Activated carbon adsorber filter element | P32KA00ESA |
| L-bracket (fits to body) | P32KA00ML |
| T-bracket (fits to body connector) | P32KA00MB |
| T-bracket with body connector | P32KA00MT |
| Body connector | P32KA00CB |
| Differential pressure indicator (replacement) | P32KA00RQ |

Flow Charts

P32FB - 1.0 micron flow

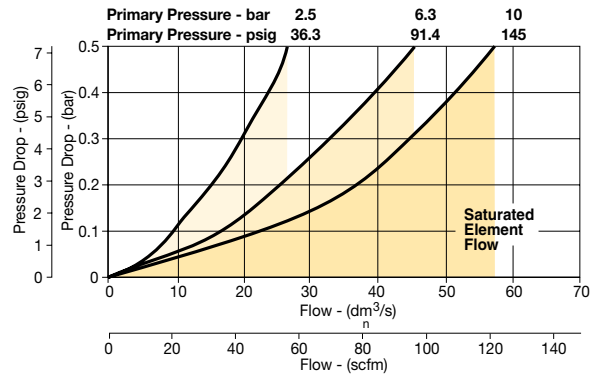

P32FB - 0.01 micron flow

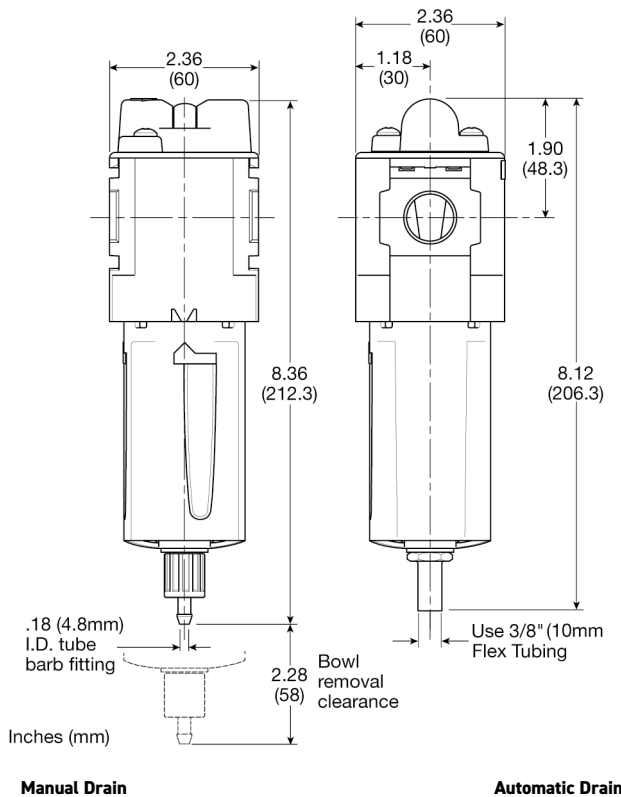
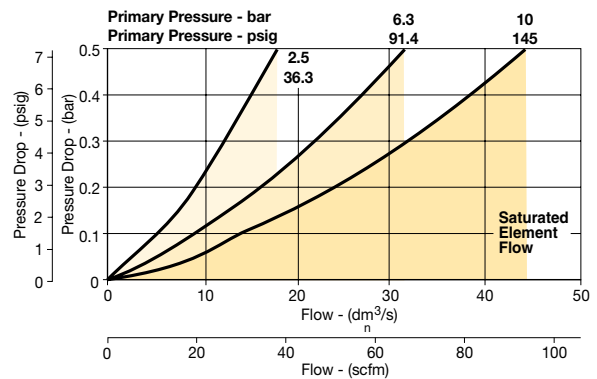

P33 Coalescing and Adsorber Filters - Standard

- Integral 1/2" or 3/4" ports (NPT, BSPP & BSPT)
- Removes liquid aerosols and sub micron particles
- Oil free air for critical applications, such as air gauging, pneumatic instrumentation and control
- Differential Pressure Indicator (DPI) standard on Coalescing Filters
- Positive bayonet latch to ensure correct & safe fitting
- Adsorbing activated carbon element removes oil vapors and most hydrocarbons



Note: To optimize the life of coalescing element, it is advisable to install a P33F pre-filter with a 5 micron element upstream of the coalescing filter.

To optimize the life of an Adsorber it is advisable to install a P33 Coalescing Filter upstream of the Adsorber. Adsorber element should be replaced approximately every 1000 hours of service.

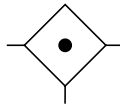

| Port Size | Description † | Element | Part Number |
|-----------|--------------------------|-------------|--------------------|
| 1/2" | Poly Bowl, Manual Drain | 0.01 micron | P33FA94DGMN |
| 1/2" | Poly Bowl, Auto Drain | 0.01 micron | P33FA94DGAN |
| 1/2" | Metal Bowl, Manual Drain | 0.01 micron | P33FA94DSMN |
| 1/2" | Metal Bowl, Auto Drain | 0.01 micron | P33FA94DSAN |
| 3/4" | Poly Bowl, Manual Drain | 0.01 micron | P33FA96DGMN |
| 3/4" | Poly Bowl, Auto Drain | 0.01 micron | P33FA96DGAN |
| 3/4" | Metal Bowl, Manual Drain | 0.01 micron | P33FA96DSMN |
| 3/4" | Metal Bowl, Auto Drain | 0.01 micron | P33FA96DSAN |

† For polycarbonate bowl, see caution in Engineering Section A.

Operating information

| | |
|---------------------------|---|
| Supply pressure (max): | |
| Poly bowl | 150 psig (10 bar) |
| Metal bowl w/ DPI | 150 psig (10 bar) |
| Metal bowl w/o DPI | 250 psig (17 bar) |
| Operating temperature: | |
| Plastic bowl | -13°F to 125°F (-25°C to 52°C) |
| Metal bowl | -13°F to 150°F (-25°C to 65.6°C) |
| Standard filtration: | 1.0 and 0.01 micron |
| Adsorber | Max. oil carryover (ppm w/w) 0.003 @ 70°F (21°C) |
| Flow capacity*: | |
| 1.0 micron coalescing | 68 scfm (32 dm³/s, ANR) |
| 0.01 micron coalescing | 42 scfm (20 dm³/s, ANR) |
| Activated carbon adsorber | 72 scfm (34 dm³/s, ANR) |
| Useful retention†: | 2.8 US oz. (85 cm³) |
| Weight: | 1.10 lb (0.50 kg) |

* Inlet pressure 91.3 psig (6.3 bar). Pressure drop 3 psig (0.2 bar), saturated element.

† Useful retention refers to volume below the quiet zone baffle.

Ordering information:

P33FA 9 6 D G M N

| | | | | | | |
|--|---|------------------------------------|--|---------------------------------|---|--|
| Basic Series Global Modular Standard Coalescing Filter P33FA | Thread Type BSPP 1 BSPT 2 NPT 9 | Port Size 1/2 4 3/4 6 | Element 0.01µ Element C 0.01µ Element with DPI D 1µ Element 9 1µ Element with DPI Q Adsorber A | Mounting N No Bracket | Drain Type M Manual Drain A Auto Drain | Bowl Type G Poly Bowl with Bowl Guard M Metal Bowl without Sight Gauge S Metal Bowl with Sight Gauge |
|--|---|------------------------------------|--|---------------------------------|---|--|

Most popular.



Standard Coalescing and Adsorber Filters

Air Preparation Products Global Air Preparation

Material Specifications

| | |
|----------------|--------------------|
| Body | Aluminum |
| Body cap | ABS |
| Plastic bowl | Polycarbonate |
| Metal bowl | Aluminum |
| Filter element | Borosilicate cloth |
| Adsorber | Activated carbon |
| Seals | Nitrile |
| Sight gauge | Nylon |

Repair and Service Kits

| | |
|---|-------------------|
| Plastic bowl / bowl guard, manual drain | P33KA00BGM |
| Metal bowl / sight gauge, manual drain | P33KA00BSM |
| Auto drain | P32KA00DA |
| 1 μ coalescing filter element | P33KA00ES9 |
| 0.01 μ coalescing filter element | P33KA00ESC |
| Activated carbon adsorber filter element | P33KA00ESA |
| L-bracket (fits to body) | P33KA00ML |
| T-bracket (fits to body connector) | P32KA00MB |
| T-bracket with body connector | P32KA00MT |
| Body connector | P32KA00CB |
| Differential pressure indicator (replacement) | P32KA00RQ |

Flow Charts

P33FA - 1.0 micron flow

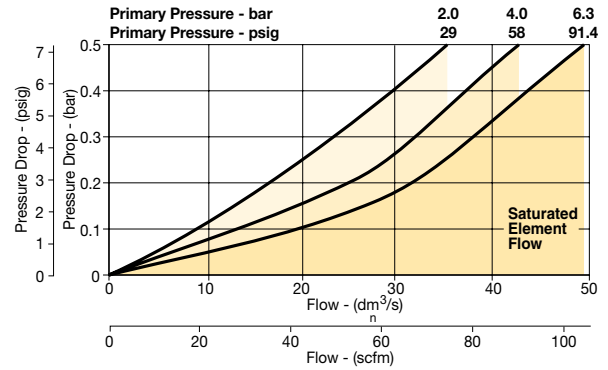

P33FA - 0.01 micron flow

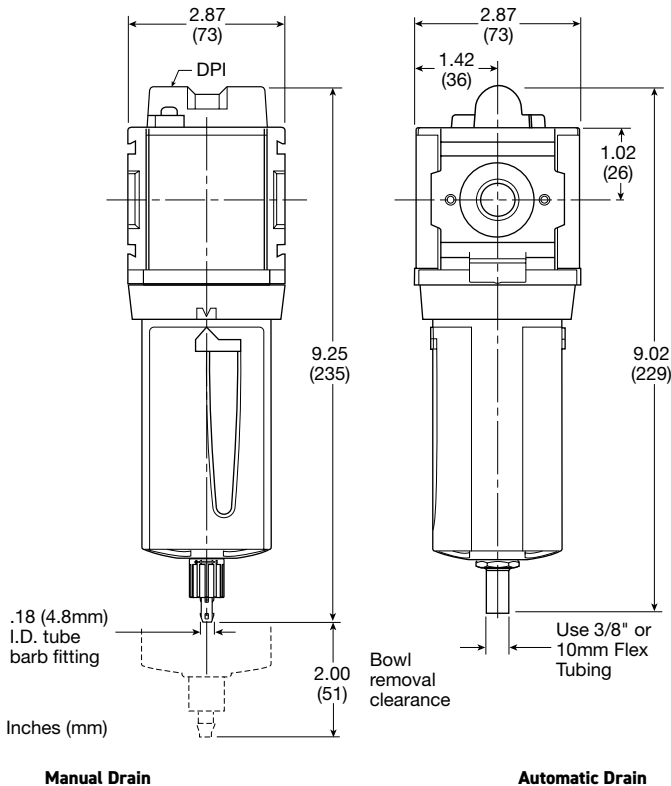
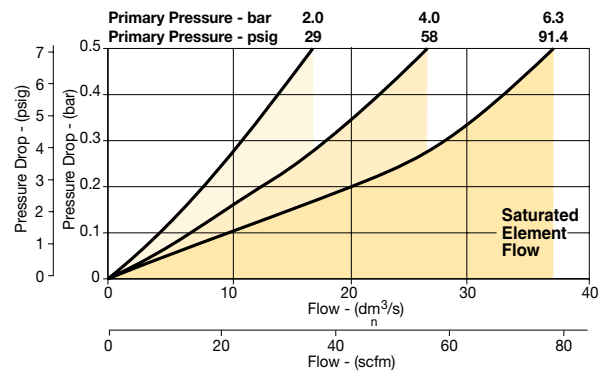

Mini Regulators

P31 Regulators - Mini

- Integral 1/4" ports (NPT, BSPP & BSPT)
- Robust but lightweight aluminum construction
- Secondary pressure ranges
- Secondary aspiration plus balanced poppet provides quick response and accurate pressure regulation.
- Relieving & non-relieving types
- Non-rising knob

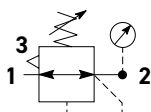

Self relieving regulator with gauge

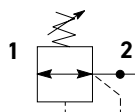

Non-relieving regulator

Operating information

| | | |
|---------------------------|-----|---|
| Flow capacity*: | 1/4 | 73 scfm (34 dm ³ /s, ANR) |
| Operating temperature†: | | -4°F to 150°F (-20°C to 65.5°C) |
| Supply pressure (max): | | 300 psig (20 bar) |
| Adjusting range pressure: | | 30 psig (0-2 bar) 60 psig (0-4 bar) 125 psig (0-8 bar) 232 psig (0-16 bar) |
| Weight: | | 0.37 lb (0.17 kg) |

* Inlet pressure 145 psig (10 bar). Secondary pressure 100 psig (6.9 bar) and 14.5 psig (1 bar) pressure drop.
† Units with square gauges: 5°F to 150°F (-15°C to 65.5°C)

Gauge supplied with every part. Gauge can be installed on the front or back of the regulator. If no gauge is installed, both seal screws must be installed.

| Port Size | Description (Relieving) | Gauge | Part Number |
|-----------|-------------------------|--------|--------------------|
| 1/4" | 125 psig (8 bar) | Square | P31RB92BN5P |

Ordering Information:

P31RB 9 2 B N 5 P

| Basic Series Global Modular Mini Regulator P31RB | Thread Type BSPP 1 BSPT 2 NPT 9 | Port Size 1/4 2 | Relief Relieving B Non-Relieving N Reverse Flow - Relieving R | Mounting P Plastic Panel Mount Nut | Adjustment Range With Square Gauge | | | | | | | | | | | | | | | |
|--|---|---------------------------|---|--|--|------|-----|-----|---------|--------|----------|--------|-------|---------|---------|-------|---------|---------|--------|---------|
| | | | | | <table border="1"> <thead> <tr> <th>psig</th> <th>Bar</th> <th>MPa</th> </tr> </thead> <tbody> <tr> <td>1 = 30*</td> <td>V = 2*</td> <td>2 = 0.2*</td> </tr> <tr> <td>3 = 60</td> <td>S = 4</td> <td>4 = 0.4</td> </tr> <tr> <td>5 = 125</td> <td>T = 8</td> <td>6 = 0.8</td> </tr> <tr> <td>7 = 232</td> <td>W = 16</td> <td>8 = 1.6</td> </tr> </tbody> </table> | psig | Bar | MPa | 1 = 30* | V = 2* | 2 = 0.2* | 3 = 60 | S = 4 | 4 = 0.4 | 5 = 125 | T = 8 | 6 = 0.8 | 7 = 232 | W = 16 | 8 = 1.6 |
| psig | Bar | MPa | | | | | | | | | | | | | | | | | | |
| 1 = 30* | V = 2* | 2 = 0.2* | | | | | | | | | | | | | | | | | | |
| 3 = 60 | S = 4 | 4 = 0.4 | | | | | | | | | | | | | | | | | | |
| 5 = 125 | T = 8 | 6 = 0.8 | | | | | | | | | | | | | | | | | | |
| 7 = 232 | W = 16 | 8 = 1.6 | | | | | | | | | | | | | | | | | | |
| | | | | Adjustment N Non-Rising Knob | | | | | | | | | | | | | | | | |

* Regulator comes with gauge respective to the adjustment range available.

Most popular.

B
 Global Air Preparation
 Introduction
 Filters
 Coalescers
 Regulators
 Filter / Regulators
 Lubricators
 Combinations
 Accessories and Kits

Air Preparation Products

Global Air Preparation

Mini Regulators

Material Specifications

| | |
|--------------------|---------------------------|
| Body | Aluminum |
| Adjustment knob | Acetal |
| Bonnet | Glass-filled nylon |
| Diaphragm assembly | Stainless steel / Nitrile |
| Valve assembly | Acetal/ Nitrile |
| Springs | Steel |
| Seals | Nitrile |
| Panel nut | Acetal |
| Bottom Cap | Glass-filled nylon |

Repair and Service Kits

| | |
|--|------------------|
| Panel mount nut - aluminum | P31KA00MM |
| Panel mount nut - plastic | P31KA00MP |
| Angle bracket (attaches via panel nut) | P31KB00MR |
| C-bracket (fits to body) | P31KA00MW |
| T-bracket with body connector | P31KA00MT |
| Body connector | P31KA00CB |

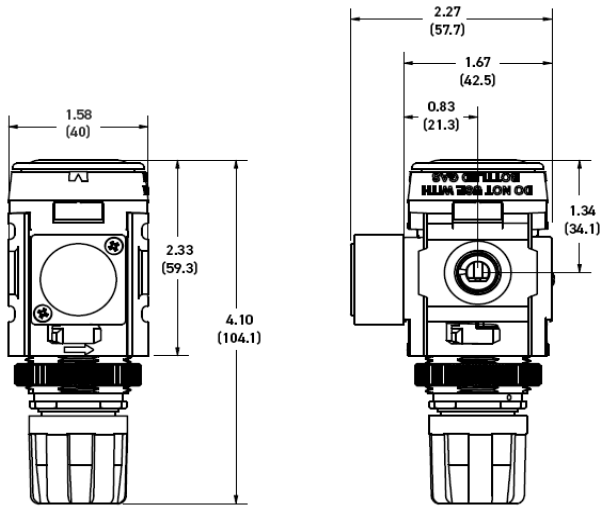

NOTE: 1.20 in. (30mm) hole required for panel nut mounting.

WARNING

**Product rupture can cause serious injury.
Do not connect regulator to bottled gas.
Do not exceed Maximum primary pressure rating.**

CAUTION:

REGULATOR PRESSURE ADJUSTMENT – The working range of knob adjustment is designed to permit outlet pressures within their full range. Pressure adjustment beyond this range is also possible because the knob is not a limiting device. This is a common characteristic of most industrial regulators, and limiting devices may be obtained only by special design. For best performance, regulated pressure should always be set by increasing the pressure up to the desired setting.

Flow Charts

P31RB 1/4" Regulator

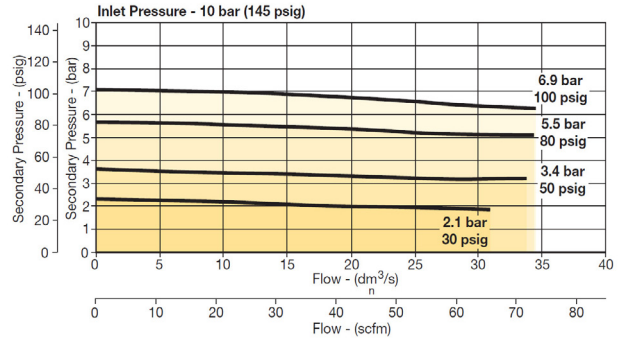

Gauges (*see note below)

| | | |
|---|-----------------------|--------------------|
| Square flush mount gauge | 0-060 psig | P31KA060XB |
| | 0-160 psig | P31KA160XB |
| | 0-290 psig | P31KA290XB |
| | 0-4 bar | P31KA04BXB |
| | 0-11 bar | P31KA11BXB |
| | 0-20 bar | P31KA20BXB |
| | 0-0.4 MPa | P31KA04MXB |
| Square flush mount gauge | 0-1.1 MPa | P31KA11MXB |
| | 0-2.0 MPa | P31KA20MXB |
| | 0-4 bar | K4511SCR04B |
| | 0-11 bar | K4511SCR11B |
| Square with adapter kit | 0-60 psig | K4511SCR060 |
| | 0-160 psig | K4511SCR160 |
| | 0-4 bar | P6G-PR10040 |
| | 0-11 bar | P6G-PR10110 |
| 1.00" Round 1/8" center back mount | 0-60 psig / 1-4 bar | K4510N18060 |
| | 0-160 psig / 0-11 bar | K4510N18160 |
| | 0-30 psig / 0-2 bar | K4515N18030 |
| | 0-60 psig / 0-4 bar | K4515N18060 |
| 40mm Round 1/8" center back mount (not for use with common port regulators) | 0-160 psig / 0-11 bar | K4515N18160 |

For best performance, regulated pressure should always be set by increasing the pressure up to the desired setting.

***For P31 Regulators with date code after November 2023 (4423 Date Code), please use these part numbers when ordering a replacement gauge.**



Mini Common P1 Regulators

P31 Common P1 Regulators - Mini

- Manifold style regulator with line pressure on both sides
- Pressure output is at front or rear
- Inlet port 1/4" (NPT, BSPP & BSPT)
- Working port 1/8"
- Robust construction
- Secondary pressure ranges
- Secondary aspiration plus balanced poppet provides quick response and accurate pressure regulation
- Relieving & non-relieving types
- Non-rising knob

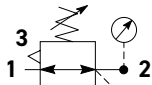
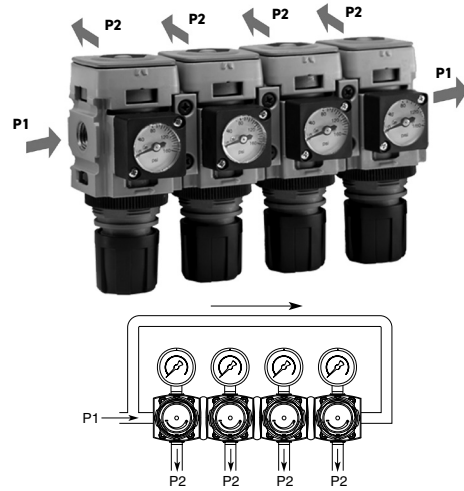

Self relieving regulator with gauge

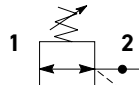

Non-relieving regulator

| Port Size | Description (Relieving) | Gauge | Part Number |
|-----------|-------------------------|--------|--------------------|
| 1/4" | 125 psig (8 bar) | Square | P31HB92BN5P |

Operating information

Flow capacity*: 1/4 64 scfm (31 dm³/s, ANR)
 Operating temperature: -4°F to 150°F (-20°C to 65.5°C)
 Supply pressure (max): 300 psig (20 bar)
 Adjusting range pressure: 30 psig (0-2 bar)
 60 psig (0-4 bar)
 125 psig (0-8 bar)
 232 psig (0-16 bar)
 P1 port size (inlet/outlet) 1/4 NPT, BSPP, BSPT
 P2 regulated ports (2 ea.) 1/8 NPT, BSPP, BSPT
 Weight: 0.66 lb (0.30 kg)
 * Inlet pressure 145 psig (10 bar). Secondary pressure 100 psig (6.9 bar) and 14.5 psig (1 bar) pressure drop.

Gauge supplied with every part. Gauge can be installed on the front or back of the regulator. If no gauge is installed, both seal screws must be installed.

Ordering Information:

P31HB 9 2 B N 5 P

| | | | | | |
|---|---|---|---|--|---|
| Basic Series Global Modular Mini Common Regulator P31HB | Thread Type BSPP 1 BSPT 2 NPT 9 | Port Size † 1/4 2 † Working port 1/8". | Relief Relieving B Non-Relieving N Reverse Flow - Relieving R | Mounting P Plastic Panel Mount Nut | Adjustment Range With Square Gauge |
|---|---|---|---|--|---|

| psig | Bar | MPa |
|---------|--------|----------|
| 1 = 30* | V = 2* | 2 = 0.2* |
| 3 = 60 | S = 4 | 4 = 0.4 |
| 5 = 125 | T = 8 | 6 = 0.8 |
| 7 = 232 | W = 16 | 8 = 1.6 |

* Regulator comes with gauge respective to the adjustment range available.

Adjustment
N Non-Rising Knob

Most popular.

P

Global Air Preparation

Introduction

Filters

Coalescers

Regulators

Filter / Regulators

Lubricators

Combinations

Accessories and Kits



Mini Common P1 Regulators

Materials of Construction

| | |
|--------------------|---------------------------|
| Body | Aluminum |
| Adjustment knob | Acetal |
| Bonnet | Glass-filled nylon |
| Diaphragm assembly | Stainless steel / Nitrile |
| Valve assembly | Acetal / Nitrile |

Repair and Service Kits

| | |
|--|------------------|
| Panel mount nut - aluminum | P31KA00MM |
| Panel mount nut - plastic | P31KA00MP |
| Angle bracket (attaches via panel nut) | P31KB00MR |
| T-bracket with body connector | P31KA00MT |
| Body connector | P31KA00CB |

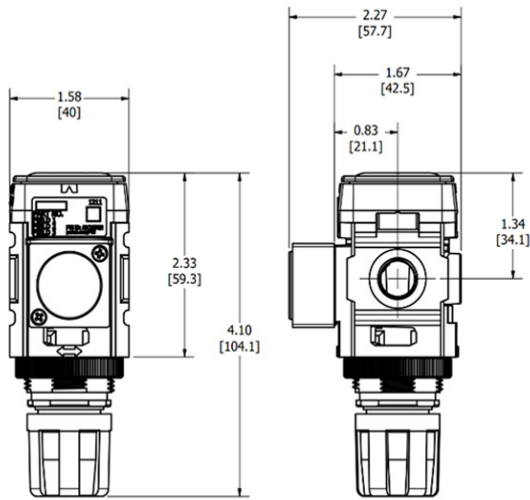

NOTE: 1.20 in. (30mm) hole required for panel nut mounting.



WARNING

**Product rupture can cause serious injury.
Do not connect regulator to bottled gas.
Do not exceed Maximum primary pressure rating.**

CAUTION:

REGULATOR PRESSURE ADJUSTMENT – The working range of knob adjustment is designed to permit outlet pressures within their full range. Pressure adjustment beyond this range is also possible because the knob is not a limiting device. This is a common characteristic of most industrial regulators, and limiting devices may be obtained only by special design. For best performance, regulated pressure should always be set by increasing the pressure up to the desired setting.

Air Preparation Products Global Air Preparation

Flow Charts

P31HB 1/4" Common Regulator

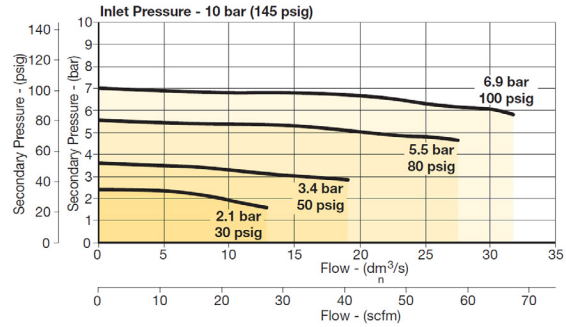

Gauges (*see note below)

| | | |
|--------------------------|-------------------------|--------------------|
| Square flush mount gauge | 0-160 psig | P31KA060XB |
| | 0-160 psig | P31KA160XB |
| | 0-290 psig | P31KA290XB |
| | 0-4 bar | P31KA04BXB |
| | 0-11 bar | P31KA11BXB |
| | 0-20 bar | P31KA20BXB |
| | 0-0.4 MPa | P31KA04MXB |
| Square flush mount gauge | 0-1.1 MPa | P31KA11MXB |
| | 0-2.0 MPa | P31KA20MXB |
| | 0-4 bar | K4511SCR04B |
| Square flush mount gauge | 0-11 bar | K4511SCR11B |
| | 0-60 psig | K4511SCR060 |
| | 0-160 psig | K4511SCR160 |
| | Square with adapter kit | 0-4 bar |
| 0-11 bar | | P6G-PR10110 |
| 0-60 psig | | P6G-PR90060 |
| 0-160 psig | | P6G-PR90160 |

| | | |
|------------------------------------|-----------------------|--------------------|
| 1.00" Round 1/8" center back mount | 0-60 psig / 1-4 bar | K4510N18060 |
| | 0-160 psig / 0-11 bar | K4510N18160 |

| | | |
|---|-----------------------|--------------------|
| 40mm Round 1/8" center back mount (not for use with common port regulators) | 0-30 psig / 0-2 bar | K4515N18030 |
| | 0-60 psig / 0-4 bar | K4515N18060 |
| | 0-160 psig / 0-11 bar | K4515N18160 |

For best performance, regulated pressure should always be set by increasing the pressure up to the desired setting.

***For P31 Regulators with date code after November 2023 (4423 Date Code), please use these part numbers when ordering a replacement gauge.**



Compact Regulators

P32 Regulators - Compact

- Integral 1/4", 3/8" or 1/2" ports (NPT, BSPP & BSPT)
- Robust but lightweight aluminum construction
- Secondary pressure ranges
- Secondary aspiration plus balanced poppet provides quick response and accurate pressure regulation
- Relieving & non-relieving types
- Regulator will reverse flow as standard
- Non-rising knob

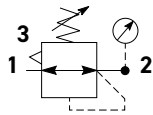

Self relieving regulator with gauge

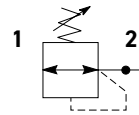

Non-relieving regulator

| Port Size | Description (Relieving) | Gauge | Part Number |
|-----------|-------------------------|-------|--------------------|
| 1/4" | 125 psig (8 bar) | None | P32RB92BNNP |
| 1/4" | 125 psig (8 bar) | Round | P32RB92BNGP |
| 3/8" | 125 psig (8 bar) | None | P32RB93BNNP |
| 3/8" | 125 psig (8 bar) | Round | P32RB93BNGP |
| 1/2" | 125 psig (8 bar) | None | P32RB94BNNP |
| 1/2" | 125 psig (8 bar) | Round | P32RB94BNGP |

Operating information

Flow capacity*:
 1/4 179 scfm (84 dm³/s, ANR)
 3/8, 1/2 201 scfm (94 dm³/s, ANR)

Operating temperature: -13°F to 150°F (-25°C to 65.5°C)

Supply pressure (max): 300 psig (20 bar)

Adjusting range pressure:
 30 psig (0-2 bar)
 60 psig (0-4 bar)
 125 psig (0-8 bar)
 250 psig (0-17 bar)

Gauge port (2 each) 1/4 NPT, BSPP, BSPT

Weight: 1.24 lb (0.56 kg)

* Inlet pressure 145 psig (10 bar). Secondary pressure 80.0 psig (5.5 bar)

Ordering Information:

P32RB 9 2 B N G P

| | | | | | | |
|--|---|---|---|--|--|--|
| Basic Series Global Modular Compact Regulator P32RB | Thread Type BSPP 1 BSPT 2 NPT 9 | Port Size 1/4 2 3/8 3 1/2 4 | Relief Relieving B Non-Relieving N | Adjustment N Non-Rising Knob | Mounting P Plastic Panel Mount Nut | Adjustment Range With Round Gauge Z 30 psig; 2 Bar; 0.2 MPa M 60 psig; 4 Bar; 0.4 MPa G 125 psig; 8 Bar; 0.8 MPa J 250 psig; 17 Bar; 1.7 MPa Without Gauge Y 30 psig; 2 Bar; 0.2 MPa L 60 psig; 4 Bar; 0.4 MPa N 125 psig; 8 Bar; 0.8 MPa H 250 psig; 17 Bar; 1.7 MPa |
|--|---|---|---|--|--|--|

* Regulator comes with gauge respective to the adjustment range selected.

Most popular.

B
Global Air Preparation
Introduction
Filters
Coalescers
Regulators
Filter / Regulators
Lubricators
Combinations
Accessories and Kits



Compact Regulators

Material Specifications

| | |
|--------------------|---------------------------|
| Body | Aluminum |
| Adjustment knob | Acetal |
| Bonnet | Glass-filled nylon |
| Diaphragm assembly | Nitrile / Stainless steel |
| Valve assembly | Acetal / Nitrile |
| Springs | Steel, stainless steel |
| Seals | Nitrile |
| Panel nut | Acetal |

Repair and Service Kits

| | |
|--|------------------|
| Panel mount nut - aluminum | P32KA00MM |
| Panel mount nut - plastic | P32KA00MP |
| Angle bracket (attaches via panel nut) | P32KB00MR |
| T-bracket with body connector | P32KA00MT |
| T-bracket | P32KA00MB |
| Body connector | P32KA00CB |

WARNING

**Product rupture can cause serious injury.
Do not connect regulator to bottled gas.
Do not exceed Maximum primary pressure rating.**

CAUTION:

REGULATOR PRESSURE ADJUSTMENT – The working range of knob adjustment is designed to permit outlet pressures within their full range. Pressure adjustment beyond this range is also possible because the knob is not a limiting device. This is a common characteristic of most industrial regulators, and limiting devices may be obtained only by special design. For best performance, regulated pressure should always be set by increasing the pressure up to the desired setting.

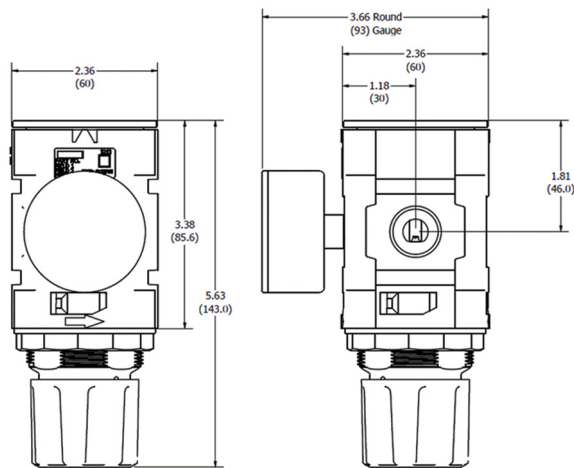

Inches (mm)

NOTE: 1.90 in. (48mm) hole required for panel nut mounting.

Air Preparation Products Global Air Preparation

Flow Charts

P32RB 1/4" Regulator

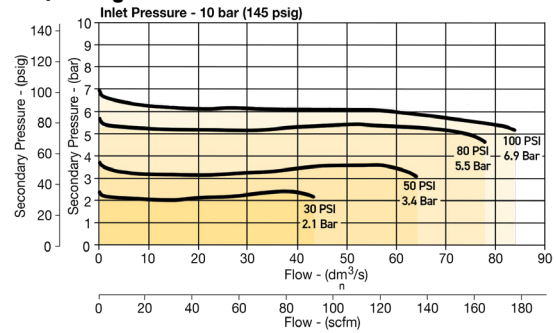

P32RB 3/8" Regulator

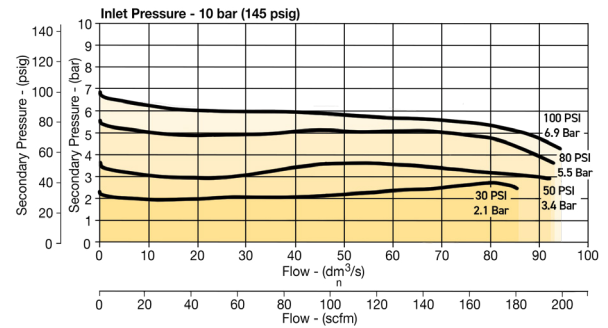

P32RB 1/2" Regulator

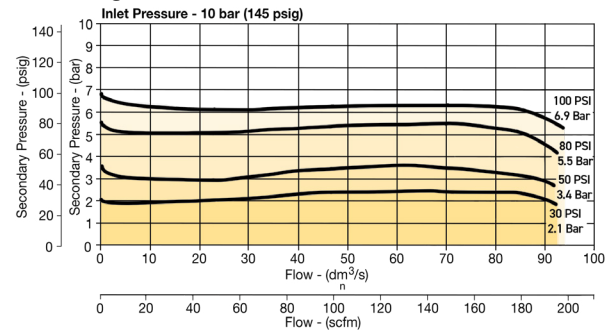

Gauges

| | | |
|--|-----------------------|--------------------|
| Square with adapter kit | 0-4 bar | P6G-PR10040 |
| | 0-11 bar | P6G-PR10110 |
| | 0-60 psig | P6G-PR90060 |
| | 0-160 psig | P6G-PR90160 |
| 50mm (2") round 1/4" center back mount | 0-30 psig / 0-2 bar | K4520N14030 |
| | 0-60 psig / 0-4 bar | K4520N14060 |
| | 0-160 psig / 0-11 bar | K4520N14160 |
| | 0-300 psig / 0-20 bar | K4520N14300 |

For best performance, regulated pressure should always be set by increasing the pressure up to the desired setting.



P32 Common - P1 Regulator - Compact

- Manifold style regulator with line pressure on both sides.
- Pressure output is at front or rear.
- Inlet ports 1/4", 3/8" or 1/2" (NPT, BSPP & BSPT)
- Working port 1/4"
- Robust construction
- Secondary pressure ranges
- Secondary aspiration plus balanced poppet provides quick response and accurate pressure regulation
- Relieving & non-relieving types
- Regulator will reverse flow as standard
- Non-rising knob

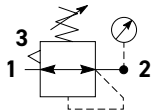
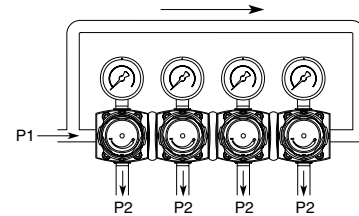

Self relieving regulator with gauge

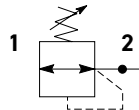

Non-relieving regulator

| Port Size | Description (Relieving) | Gauge | Part Number |
|-----------|-------------------------|-------|--------------------|
| 1/4" | 125 psig (8 bar) | None | P32HB92BNNP |
| 3/8" | 125 psig (8 bar) | None | P32HB93BNNP |
| 1/2" | 125 psig (8 bar) | None | P32HB94BNNP |

Operating information

Flow capacity*: 1/4, 3/8, 1/2 94 scfm (44 dm³/s, ANR)
 Operating temperature: -25°C to 65.5°C (-13°F to 150°F)
 Supply pressure (max): 300 psig (20 bar)
 Adjusting range pressure: 0 to 30 psig (0 to 2 bar)
 0 to 60 psig (0 to 4 bar)
 0 to 125 psig (0 to 8 bar)
 0 to 232 psig (0 to 16 bar)
 Gauge port (2 each): 1/4 NPT, BSPP, BSPT
 Weight: 1.21 lb (0.55 kg)
 * Inlet pressure 145 psig (10 bar). Secondary pressure 80.0 psig (5.5 bar) and 14.5 psig (1 bar) pressure drop.

Ordering Information:

P32HB 9 2 B N N P

| | | | | | |
|--|---|--|---|--|--|
| Basic Series Global Modular Compact Regulator P32HB | Thread Type BSPP 1 BSPT 2 NPT 9 | Port Size † 1/4 2 3/8 3 1/2 4 <small>† Working port 1/4".</small> | Relief Relieving B Non-Relieving N | Adjustment N Non-Rising Knob | Mounting P Plastic Panel Mount Nut |
|--|---|--|---|--|--|

| Adjustment Range | |
|-------------------------|---------------------------|
| With Round Gauge | |
| Z | 30 psig; 2 Bar; 0.2 MPa |
| M | 60 psig; 4 Bar; 0.4 MPa |
| G | 125 psig; 8 Bar; 0.8 MPa |
| J | 250 psig; 17 Bar; 1.7 MPa |
| Without Gauge | |
| Y | 30 psig; 2 Bar; 0.2 MPa |
| L | 60 psig; 4 Bar; 0.4 MPa |
| N | 125 psig; 8 Bar; 0.8 MPa |
| H | 250 psig; 17 Bar; 1.7 MPa |

* Regulator comes with gauge respective to the adjustment range selected.

☐ Most popular.

Global Air Preparation

Introduction

Filters

Coalescers

Regulators

Filter / Regulators

Lubricators

Combinations

Accessories and Kits

Compact Common P1 Precision Regulator

Material Specifications

| | |
|--------------------|---------------------------|
| Body | Aluminum |
| Adjustment knob | Acetal |
| Bonnet | Glass-filled nylon |
| Diaphragm assembly | Nitrile / Stainless steel |
| Valve assembly | Acetal / nitrile |
| Springs | Steel, stainless steel |
| Seals | Nitrile |
| Panel nut | Acetal |

Repair and Service Kits

| | |
|--|------------------|
| Panel mount nut - aluminum | P32KA00MM |
| Panel mount nut - plastic | P32KA00MP |
| Angle bracket (attaches via panel nut) | P32KB00MR |
| T-bracket with body connector | P32KA00MT |
| T-bracket | P32KA00MB |
| Body connector | P32KA00CB |

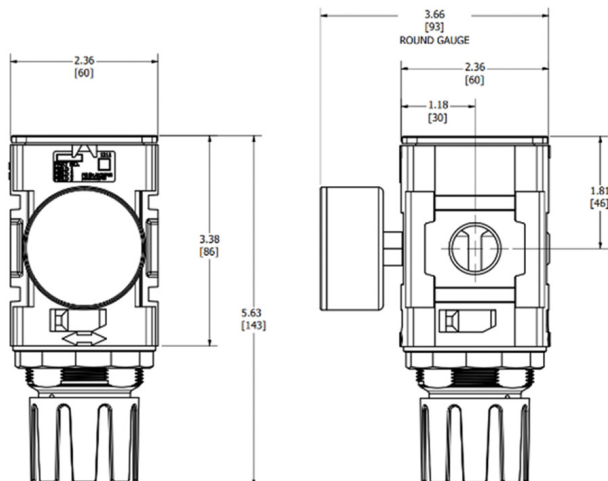

NOTE: 1.90 in. (48mm) hole required for panel nut mounting.

Air Preparation Products Global Air Preparation

Flow Charts

P32HB Common Port Regulator

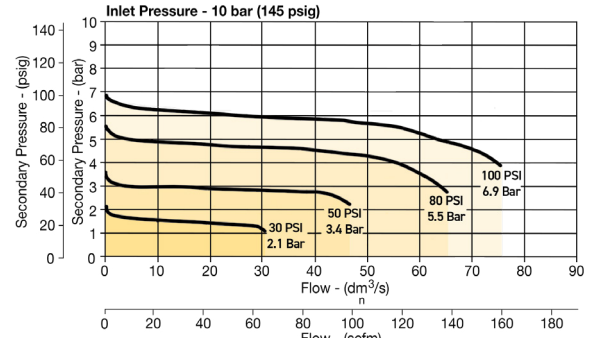

WARNING

**Product rupture can cause serious injury.
Do not connect regulator to bottled gas.
Do not exceed Maximum primary pressure rating.**

CAUTION:

REGULATOR PRESSURE ADJUSTMENT – The working range of knob adjustment is designed to permit outlet pressures within their full range. Pressure adjustment beyond this range is also possible because the knob is not a limiting device. This is a common characteristic of most industrial regulators, and limiting devices may be obtained only by special design. For best performance, regulated pressure should always be set by increasing the pressure up to the desired setting.

Gauges

| | | |
|--|-----------------------|--------------------|
| Square with adapter kit | 0-4 bar | P6G-PR10040 |
| | 0-11 bar | P6G-PR10110 |
| | 0-60 psig | P6G-PR90060 |
| | 0-160 psig | P6G-PR90160 |
| 50mm (2") round 1/4" center back mount | 0-30 psig / 0-2 bar | K4520N14030 |
| | 0-60 psig / 0-4 bar | K4520N14060 |
| | 0-160 psig / 0-11 bar | K4520N14160 |
| | 0-300 psig / 0-20 bar | K4520N14300 |

For best performance, regulated pressure should always be set by increasing the pressure up to the desired setting.



Standard Regulators

P33 Regulators - Standard

- Integral 1/2" or 3/4" ports (NPT, BSPP & BSPT)
- Robust but lightweight aluminum construction
- Secondary pressure ranges
- Secondary aspiration plus balanced poppet provides quick response and accurate pressure regulation
- Relieving & non-relieving types
- Non-rising knob

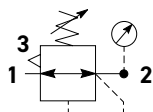

Self relieving regulator with gauge

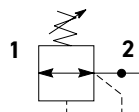

Non-relieving regulator

Operating information

Flow capacity*: 1/2, 3/4 233 scfm (110 dm³/s, ANR)
 Operating temperature: -13°F to 150°F (-25°C to 65.5°C)
 Supply pressure (max): 300 psig (20 bar)
 Adjusting range pressure: 0 to 30 psig (0 to 2 bar)
 0 to 60 psig (0 to 4 bar)
 0 to 125 psig (0 to 8 bar)
 0 to 250 psig (0 to 17 bar)
 Gauge port (2 each): 1/4 NPT, BSPP, BSPT
 Weight: 1.37 lb (0.62 kg)
 * Inlet pressure 145 psig (10 bar). Secondary pressure 91.3 psig (6.3 bar) and 14.5 psig (1 bar) pressure drop.

| Port Size | Description (Relieving) | Gauge | Part Number |
|-----------|-------------------------|-------|--------------------|
| 1/2" | 125 psig (8 bar) | None | P33RA94BNNP |
| 1/2" | 125 psig (8 bar) | Round | P33RA94BNGP |
| 3/4" | 125 psig (8 bar) | None | P33RA96BNNP |
| 3/4" | 125 psig (8 bar) | Round | P33RA96BNGP |

Ordering Information:

P33RA 9 6 B N G P

| | | | | | | |
|---|---|------------------------------------|---|--|--|--|
| Basic Series Global Modular Standard Regulator P33RA | Thread Type BSPP 1 BSPT 2 NPT 9 | Port Size 1/2 4 3/4 6 | Relief Relieving B Non-Relieving N Reverse Flow-Relieving R | Adjustment Non-Rising Knob N | Mounting P Plastic Panel Mount Nut | Adjustment Range With Round Gauge Z 30 psig; 2 Bar; 0.2 MPa M 60 psig; 4 Bar; 0.4 MPa G 125 psig; 8 Bar; 0.8 MPa J 250 psig; 17 Bar; 1.7 MPa Without Gauge Y 30 psig; 2 Bar; 0.2 MPa L 60 psig; 4 Bar; 0.4 MPa N 125 psig; 8 Bar; 0.8 MPa H 250 psig; 17 Bar; 1.7 MPa |
|---|---|------------------------------------|---|--|--|--|

Most popular.

B
 Global Air Preparation
 Introduction
 Filters
 Coalescers
 Regulators
 Filter / Regulators
 Lubricators
 Combinations
 Accessories and Kits

Standard Regulators

Material Specifications

| | |
|--------------------|------------------------|
| Body | Aluminum |
| Adjustment knob | Acetal |
| Body cap | ABS |
| Bonnet | Glass-filled nylon |
| Diaphragm assembly | Nitrile / zinc |
| Valve assembly | Brass / nitrile |
| Springs | Steel, stainless steel |
| Seals | Nitrile |
| Panel nut | Acetal |

Repair and Service Kits

| | |
|--|------------------|
| Diaphragm repair kit - relieving | P33KA00RB |
| Diaphragm repair kit - non-relieving | P33KA00RC |
| Panel mount nut - aluminum | P33KA00MM |
| Panel mount nut - plastic | P33KA00MP |
| Angle bracket (attaches via panel nut) | P33KA00MR |
| T-bracket with body connector | P32KA00MT |
| T-bracket | P32KA00MB |
| Body connector | P32KA00CB |



WARNING

**Product rupture can cause serious injury.
Do not connect regulator to bottled gas.
Do not exceed Maximum primary pressure rating.**

CAUTION:

REGULATOR PRESSURE ADJUSTMENT – The working range of knob adjustment is designed to permit outlet pressures within their full range. Pressure adjustment beyond this range is also possible because the knob is not a limiting device. This is a common characteristic of most industrial regulators, and limiting devices may be obtained only by special design. For best performance, regulated pressure should always be set by increasing the pressure up to the desired setting.

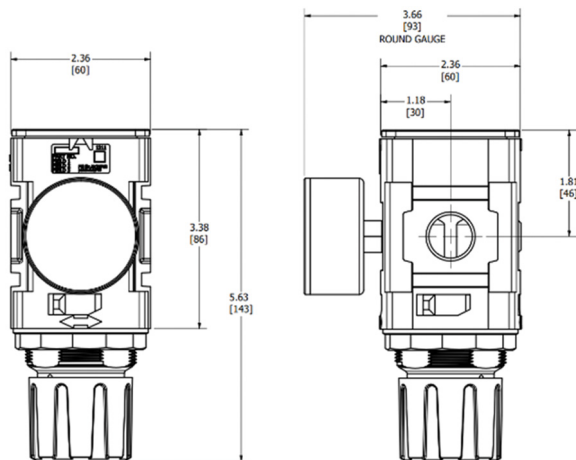

NOTE: 2.40 in. (61mm) hole required for panel nut mounting.

Air Preparation Products Global Air Preparation

Flow Charts

P33RA 1/2" Regulator

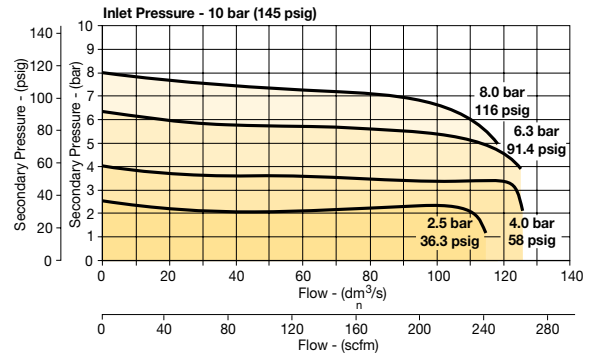

P33RA 3/4" Regulator

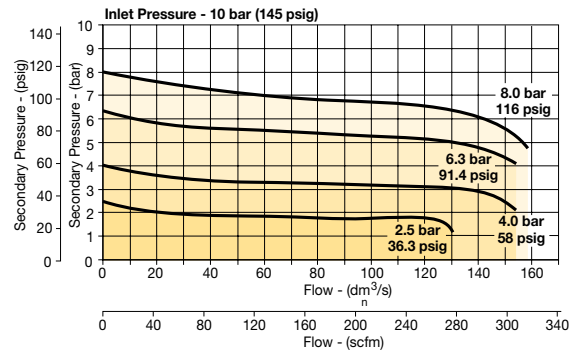

Gauges

| | | |
|------------------------|-----------------------|--------------------|
| 50mm (2") round | 0-30 psig / 0-2 bar | K4520N14030 |
| 1/4" center back mount | 0-60 psig / 0-4 bar | K4520N14060 |
| | 0-160 psig / 0-11 bar | K4520N14160 |
| | 0-300 psig / 0-20 bar | K4520N14300 |

For best performance, regulated pressure should always be set by increasing the pressure up to the desired setting.



Proportional Regulators

P31P & P32P Proportional Regulators

- Very fast response times
- Accurate output pressure
- Parameter settings
- Selectable I/O parameters
- Quick, full flow exhaust
- LED display indicates output pressure
- No air consumption in steady state
- Multiple mounting options
- Protection to IP65



P31P Series
Bottom exhaust



P32P Series
Bottom exhaust

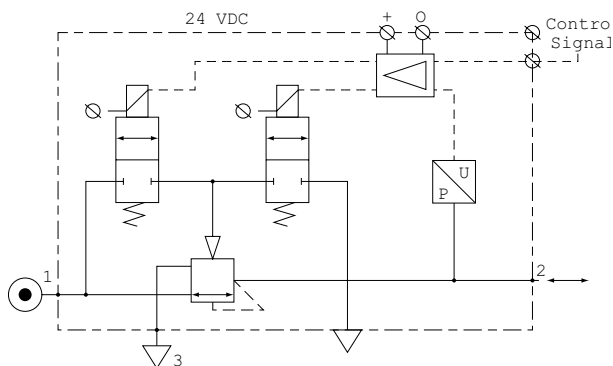

| Port Size | Description | Part Number |
|-----------|-------------------------------|-----------------------|
| 1/4" | 145 psig (0-10 bar), NC 0-10V | P31PA92AD2VD1A |
| 1/2" | 145 psig (0-10 bar), NC 0-10V | P32PA94AD2VD1A |

Operating information

| | | |
|---------------------------|---|---------------------------------------|
| Flow capacity*: | P31P | 40 scfm (19 dm ³ /s, ANR) |
| | P32P | 120 scfm (57 dm ³ /s, ANR) |
| Temperature range: | 32°F to 122°F (0°C to 50°C) | |
| Supply pressure (max): | 2 bar unit | 36.3 psig (2.5 bar) |
| | 10 bar unit | 152 psig (10.5 bar) |
| Operating pressure (min): | P2 pressure + 7.3 psig (0.5 bar) | |
| Working medium: | Compressed air or inert gasses, filtered to 40µ | |
| Pressure range: | 0 to 30 psig (0 to 2 bar) | |
| | 0 to 145 psig (0 to 10 bar) | |
| Weight: | P31P | 0.64 lb (0.291 kg) |
| | P32P | 1.42 lb (0.645 kg) |

* Inlet pressure 91.3 psig (6.3 bar), inlet pressure and 4.9 psig (0.34 bar) pressure drop.

Ordering Information:

P31PA 9 2 A D 2 V D 1 A

| | | | | |
|-------------------------------------|--|---------------------|-----------------------|------------------------|
| Body Size | Thread Type | Power Supply | Control Signal | Input Connector |
| Global Modular Mini (1/4") P31PA | BSPP 1 | 2 24 Volts | V 0-10V [‡] | 1 M12 (4-pin) |
| Global Modular Compact (1/2") P32PA | BSPT 2 NPT 9 | | | |
| Port Size | Pressure Range | | | Output Signal |
| Global Modular Mini (1/4") 2 | Z 0 - 29 psig (0 - 2 Bar) | | | D Digital, PNP |
| Global Modular Compact (1/2") 4 | D 0 - 145 psig (0 - 10 Bar) | | | P PNP or 0-10V |
| | | | | N NPN or 0-10V |
| | | | | M 4-20mA Fixed |
| | Version | | | |
| | Bottom Ported Exhaust (NC) A | | | |
| | Bottom Ported Forced Exhaust (NO) [†] E | | | |

† When the supply voltage is lost the unit will automatically exhaust the regulated pressure to 0 bar (atmospheric pressure)

‡ Factory setting is 0-10 V control signal. 4-20 mA control signal available via parameter 4 on keypad.

D) Digital PNP output only, no analog output selectable
 P) Digital PNP and analogue 0-10V outputs selectable, by means of parameter 6. (Factory default 0-10V)
 N) Digital NPN and analog 0-10 V outputs selectable by means of parameter 6. (Factory default 0-10V)
 M) Analog 4-20mA output only.
 Note: On all analog outputs the F.S. value can be adjusted by means of parameter 8.

Most popular.

B Global Air Preparation
 Introduction
 Filters
 Coalescers
 Regulators
 Filter / Regulators
 Lubricators
 Combinations
 Accessories and Kits



Proportional Regulators

Technical Information

Accuracy

+/- 1.0% of F.S.*

* Full scale (F.S.) - For 2 bar (29 psig) versions this will be 2 bar (29 psig), for the 10 bar (145 psig) version full scale will be 10 bar (145 psig).

Air consumption

No consumption in stable regulated situation.

Display

The regulator is provided with a digital display, indicating the output pressure, either in bar or psig.

The factory setting is as indicated on the label, can be changed through to software at all times (parameter 14)

Supply voltage

24 VDC +/- 10%

Power consumption

Max. 1.1W with unloaded signal outputs

Control signals

The electronic pressure regulator can be externally controlled through an analogue control signal of either 0-10V or 4-20mA. (parameter 4).

Output signals

As soon as the output pressure is within the signal band a signal is given of 24VDC, PNP Ri = 1 kOhm
Outside the signal band this connection is 0V.

Connections

(In case of output signal (Option D)

Central M12 connector 4-pole

The electrical connections are as follows:

| Pin No. | Function | Color |
|---------|--------------------------------------|-------|
| 1 | 24 V Supply | Brown |
| 2 | 0 to 10 V Control Signal Ri = 100k Ω | White |
| | 4 to 20mA Control Signal Ri = 500 Ω | |
| 3 | 0 V (GND) Supply & Set Point Ground | Blue |
| 4 | 24 V Alarm Output Signal | Black |

Air Preparation Products Global Air Preparation

Flow Charts

P31P Regulator 1/4" Ports

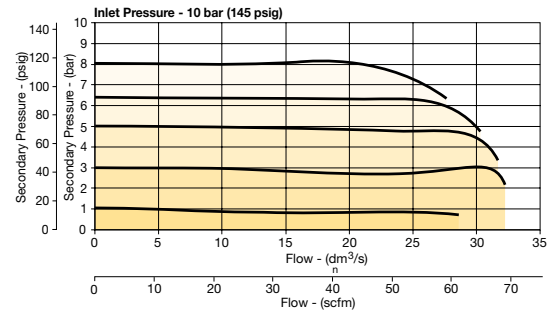

P32P Regulator 1/2" Ports

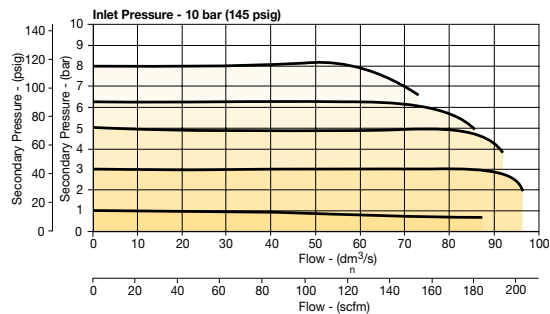

Degree of protection: IP65

EU conformity

CE: standard

EMC: according to directive 89/336/EEC

This pressure regulator is in accordance with:

EN 61000-6-1:2001 **EN 61000-6-2:2001**
EN 61000-6-3:2001 **EN 61000-6-4:2001**

Mounting position

Preferably vertical, with the cable gland on top.

Materials: P31P & P32P

| | |
|---------------------------------------|----------------|
| Magnet core | Steel |
| Solenoid valve poppet | FPM |
| Solenoid valve housing | Techno polymer |
| Regulator body (P31P & P32P versions) | Aluminum |
| Regulator top housing | Nylon |
| Valve head | Brass & NBR |
| Remaining seals | NBR |



Proportional Regulators

How to change parameters – How to Videos available at www.pdnetools.com

Pressing the Accept key “acc” for more than 3 seconds, will activate parameter change mode. The user can then select the parameters by pressing up or down key (display will show Pxx). When parameter number is correct, pressing accept again will enter parameter number (display will show parameter value).

Pressing the up or down key will change the parameter itself (display will flash indicating parameter editing mode). Pressing the accept key will accept the new parameter value (all digits will flash whilst being accepted).

After releasing all keys, the next parameter number will be presented on the display (you may step to the next parameter). When no key is pressed, after 3 seconds the display will show the actual output pressure.

When the unit is initially powered up allow approximately 10 seconds for the unit to “boot-up” before changing parameter settings.

Only parameter numbers 0, 4, 6, 8, 9, 14, 18, 19, 20, 12, 13 and 21 are accessible to edit. All other parameters are fixed.

Manual mode:











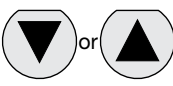

When keys DOWN and UP are pressed during startup, (connecting to the 24V power supply) manual mode is activated. This means that the user is able to in/decrease the output pressure of the regulator, by pressing the UP or DOWN key. During this action the display will blink, indicating that the manual mode is activated. After powering up again, the unit will revert back to normal mode.

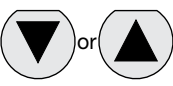
Back to Factory Setting

After start up. (Power is on)

Entering this value in parameter 0 will store the calibrated factory data into the working parameters. (Default calibration data is used)











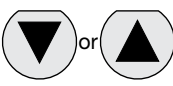

Parameter Number 0 - Reset Back to Factory Settings

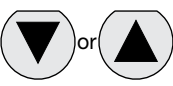
| Step | 1 | 2 | 3 | 4 | 5 | |
|---|--|--|--|---|--|--|
| Press  |  3-6 seconds |  |  |  |  | |
| Until Display Reads |  |  |  Flashing Decimal |  Flashing Decimal |  Flashing |  |
| Description | Accesses changeable parameters. | Accesses parameter no. 0. | Displays current parameter value. | Edits parameter. 3 = standard factory settings. If other than 3, use Up or Down Arrow and accept 3 | Accepts and saves new parameter setting. | Sequences to next parameter. |

Set Control Signal

The unit is factory set for 0-10 V control signal. If 4-20 mA control signal is required, change parameter 4.

Parameter Number 4 - Set Control Signal in Volts or Milliamps

| Step | 1 | 2 | 3 | 4 | 5 | |
|---|--|---|---|--|---|---|
| Press  |  3-6 seconds |  |  |  |  | |
| Until Display Reads |  |  |  Flashing Decimal |  Flashing Decimal |  Flashing |  |
| Description | Accesses changeable parameters. | Accesses parameter no. 4. | Displays current parameter value. 1 = V 0 = mA | Edits parameter. | Accepts and saves new parameter setting. | Sequences to next parameter. |

How to Videos at www.pdnetools.com

B
 Global Air Preparation
 Introduction
 Filters
 Coalescers
 Regulators
 Filter / Regulators
 Lubricators
 Combinations
 Accessories and Kits



Proportional Regulators

Set Output Signal

Parameter 6 is used to set the type of output signal to your PLC.
This parameter is used as follows:

Output Signal option "0" = Digital Output - PNP

- Factory set at "0" Non Adjustable

Output Signal option "P" = Digital PNP or Analog 1-10V

- Factory set at "1" for Analog Signal
- Convert to Digital PNP by changing parameter to "0" setting











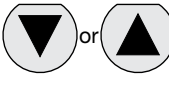

Output Signal option "N" = Digital NPN or Analog 1-10V

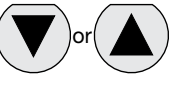
- Factory set at "1" Analog Signal
- Convert to Digital NPN by changing parameter to "0"

Output Signal option "M" = Analog 4-20 mA

- Factory set at "2" Non Adjustable

Parameter Number 6 - Set Output Signal

| Step | 1 | 2 | 3 | 4 | 5 | |
|--|--|---|---|--|---|---|
| Press  |  3-6 seconds |  |  |  |  | |
| Until Display Reads |  |  |  Flashing Decimal |  Flashing Decimal (Value 0, 1 or 2) |  Flashing |  |
| Description | Accesses changeable parameters. | Accesses parameter no. 6. | Displays current parameter value. 1 = m factory default for P3H with analog options | Edits parameter. 0 = digital (NPN or PNP) 1 = analog 0..10V 2 = analog 4..20 mA | Accepts and saves new parameter setting. | Sequences to next parameter. |











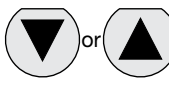

Adjust Span Analog Output Signal

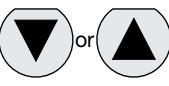
Set value is a % of Full Analog range. As an example for a 0-10V output signal, the original factory setting of 100% will give you an adjustment of 0-10V. If you reset Parameter 8 to 50%, the new output range would be 0-5V or 50% of the full range.

In the event that the output signal is to low, in a certain application, you can adjust it by increasing Parameter 8 to a maximum value of 130% of scale.

Note that all values are nominal and that an actual measurement may be required to ensure signal strength.

Parameter Number 8 - Adjust Span Analog Output Signal

| Step | 1 | 2 | 3 | 4 | 5 | |
|--|--|---|---|--|---|---|
| Press  |  3-6 seconds |  |  |  |  | |
| Until Display Reads |  |  |  Flashing Decimal (For 2 bar versions value = 92) |  Flashing Decimal (Value between 0 and 130) |  Flashing |  |
| Description | Accesses changeable parameters. | Accesses parameter no. 8. | Displays current parameter value. | Edits parameter. | Accepts and saves new parameter setting and implements the new analog signal span. | Sequences to next parameter. |

How to Videos at www.pdnetools.com

















Proportional Regulators

Adjust Digital Display

If necessary, adjustments can be made to the digital display when using an external pressure sensor.















Parameter Number 9 - Adjust Digital Display Value (Pressure Calibration)

| Step | 1 | 2 | 3 | 4 | 5 | |
|---|--|--|---|--|---|---|
| Press  |  3-6 seconds |  or  |  |  or  |  | |
| Until Display Reads |  |  |  Flashing Decimal |  Flashing Decimal |  Flashing |  |
| Description | Accesses changeable parameters. | Accesses parameter no. 9. | Displays current digital display | Use up or down arrows and accept to adjust the display value if using an external pressure sensor. | Accepts and saves new parameter setting. | Sequences to next parameter. |

Set Pressure Scale

Units with NPT port threads are supplied with a factory set psig pressure scale. Use parameter 14 to change scale to bar.

Parameter Number 14 - Set Pressure Scale in psig or bar

| Step | 1 | 2 | 3 | 4 | 5 | |
|---|--|--|---|--|---|---|
| Press  |  3-6 seconds |  or  |  |  or  |  | |
| Until Display Reads |  |  |  Flashing Decimal |  Flashing Decimal |  Flashing |  |
| Description | Accesses changeable parameters. | Accesses parameter no. 14. | Displays current parameter value. 1 = psig 0 = bar 2 = MPa | Edits parameter. | Accepts and saves new parameter setting. | Sequences to next parameter. |

How to Videos at www.pdnetools.com











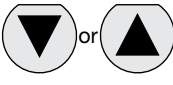

B
Global Air Preparation
Introduction
Filters
Coalescers
Regulators
Filter / Regulators
Lubricators
Combinations
Accessories and Kits

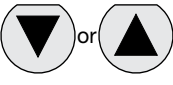

Proportional Regulators

Preset Minimum Pressure

If there is a need for a pre-set Minimum pressure, use parameter 18. (Note: preset pressure is affected by % P19.)

| Parameter Number 18 - Set Minimum Preset Pressure | | | | | | |
|---|--|---|--|---|---|---|
| Step | 1 | 2 | 3 | 4 | 5 | |
| Press  |  3-6 seconds |  |  |  |  | |
| Until Display Reads |  |  |  Flashing Decimal Displays current parameter value. Incremental value is: 2 bar unit: x 2 mbar x % P19 10 bar unit: x 10 mbar x % P19 |  Flashing Decimal (value between 0 and 200) |  Flashing |  |
| Description | Accesses changeable parameters. | Accesses parameter no. 18. | Displays current parameter value. Incremental value is: 2 bar unit: x 2 mbar x % P19 10 bar unit: x 10 mbar x % P19 | Edits parameter. | Accepts and saves new parameter setting. | Sequences to next parameter. |











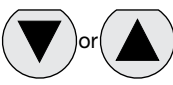

Set Pressure Correction

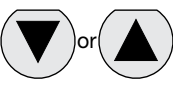
Pressure correction allows the user to set a Maximum pressure as a percentage of secondary pressure F.S.

Example: If F.S. is 10 bar, set parameter 19 to 50 for Maximum preset pressure of 5 bar.

Pressure correction also affects the Minimum preset pressure in parameter 18.

Example: If F.S. is 10 bar and parameter 18 is set to a value of 100 (1 bar), and parameter 19 is set to 50%, then the actual Minimum preset pressure seen is 0.5 bar.

| Parameter Number 19 - Set Maximum Preset Pressure | | | | | | |
|---|--|---|---|---|---|---|
| Step | 1 | 2 | 3 | 4 | 5 | |
| Press  |  3-6 seconds |  |  |  |  | |
| Until Display Reads |  |  |  Flashing Decimal Displays current parameter value. Incremental value is: % of F.S. |  Flashing Decimal (value between 0 and 100) |  Flashing |  |
| Description | Accesses changeable parameters. | Accesses parameter no. 19. | Displays current parameter value. Incremental value is: % of F.S. | Edits parameter. | Accepts and saves new parameter setting. | Sequences to next parameter. |

How to Videos at www.pdnetools.com

















Proportional Regulators

Behavior Control

The regulation speed of the pressure regulator can be modified by means of one parameter. (P 20)
The value in this parameter has a range from 0-5. A higher value indicates slower regulation speed, but will be more stable.

Parameter Number 20 - Set Behavior Control















| Step | 1 | 2 | 3 | 4 | 5 | |
|---|--|--|---|--|---|---|
| Press  |  3-6 seconds |  or  |  |  or  |  | |
| Until Display Reads |  |  |  Flashing Decimal |  Flashing Decimal (value between 0 and 5) |  Flashing |  |
| Description | Accesses changeable parameters. | Accesses parameter no. 20. | Displays current parameter value. | Edits parameter 0 = custom set* 1 = fastest (narrow proportional band) 2 = fast 3 = normal 4 = slow 5 = slowest (proportional band is broad) | Accepts and saves new parameter setting. | Sequences to next parameter. |

* When the value 0 is entered, you are able to create your own custom settings true parameters 12, 13 and 21.

**Fine Settings
Set Proportional Band**

Proportional band is used for setting the reaction sensitivity of the regulator. The displayed value is X 10 mbar and has a range between 50 (0.5 bar) and 250 (2.5 bar).

Parameter Number 12 - Set Proportional Band (P20 Must be Set to 0)

| Step | 1 | 2 | 3 | 4 | 5 | |
|---|--|--|---|--|---|---|
| Press  |  3-6 seconds |  or  |  |  or  |  | |
| Until Display Reads |  |  |  Flashing Decimal |  Flashing Decimal (value between 50 and 250) |  Flashing |  |
| Description | Accesses changeable parameters. | Accesses parameter no. 12. | Displays current parameter value. Incremental value is: x 10 mbar | Edits parameter. | Accepts and saves new parameter setting. | Sequences to next parameter. |

How to Videos at www.pdnetools.com

B
Global Air Preparation
Introduction
Filters
Coalescers
Regulators
Filter / Regulators
Lubricators
Combinations
Accessories and Kits













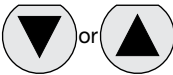

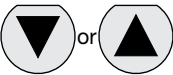
Proportional Regulators

Set Deadband











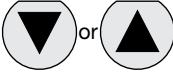

Deadband is the Minimum limit of accuracy at which the regulator is set for normal operation. The displayed value is X 10 mbar and has a range between 4 (40 mbar) and 40 (400 mbar).

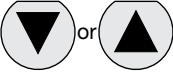
Parameter Number 13 - Set Deadband (P20 Must be Set to 0)







| Step | 1 | 2 | 3 | 4 | 5 | |
|--|--|---|---|--|---|---|
|  Press 3-6 seconds |  acc |  or |  acc |  or |  acc | |
| Until Display Reads |  |  |  Flashing Decimal |  Flashing Decimal (value between 4 and 40) |  Flashing |  |
| Description | Accesses changeable parameters. | Accesses parameter no. 13. | Displays current parameter value. Incremental value is x 10 mbar | Edits parameter. | Accepts and saves new parameter setting. | Sequences to next parameter. |

Proportional Effect

Parameter Number 21 - Set Proportional Effect (P20 Must be Set to 0)

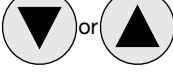
| Step | 1 | 2 | 3 | 4 | 5 | |
|---|---|--|---|---|---|---|
|  Press 3-6 seconds |  acc |  or |  acc |  or |  acc | |
| Until Display Reads |  |  |  Flashing Decimal |  Flashing Decimal (value between 5 and 100) |  Flashing |  |
| Description | Accesses changeable parameters. | Accesses parameter no. 21. | Displays current parameter value. | Edits parameter. 5 = fastest regulation 100 = slowest regulation. | Accepts and saves new parameter setting. | Sequences to next parameter. |

Parameter Number 39 - Displays Current Software Version

| Step | 1 | 2 | 3 |
|--|--|---|---|
|  Press 3-6 seconds |  acc |  or |  acc |
| Until Display Reads |  |  |  Flashing Decimal |
| Description | Accesses changeable parameters. | Accesses parameter no. 39. | Displays current parameter value. XXX = current software version |

How to Videos at www.pdnetools.com

B

Global Air Preparation

Introduction

Filters

Coalescers

Regulators

Filter / Regulators

Lubricators

Combinations

Accessories and Kits



Dimensional Data

P31P

Dimensions inches (mm)

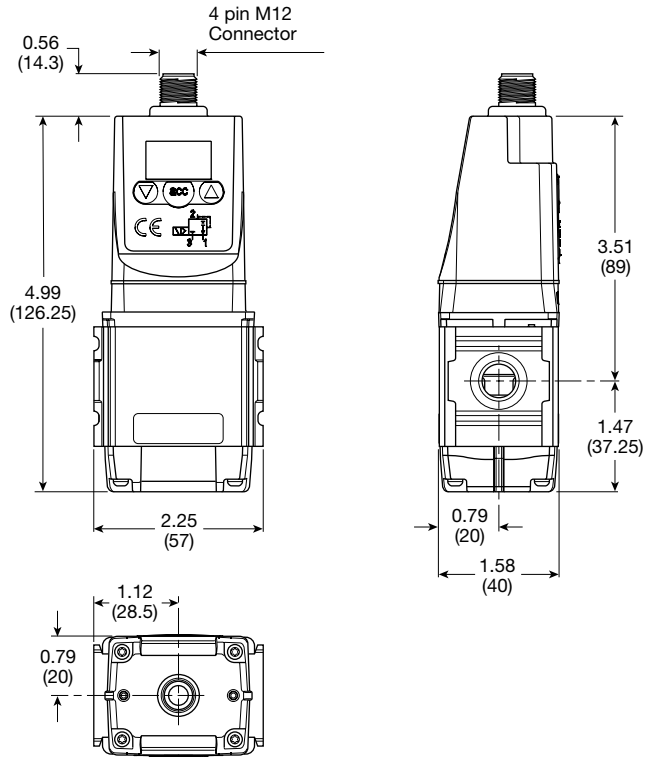

L-Bracket
P3HKA00ML

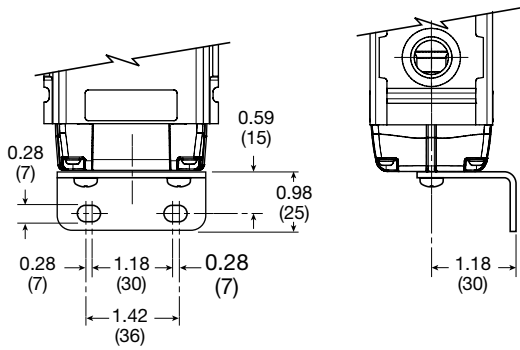

Foot Bracket
P3HKA00MC

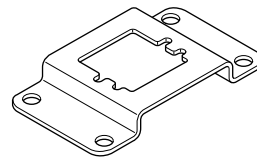
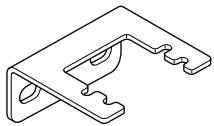
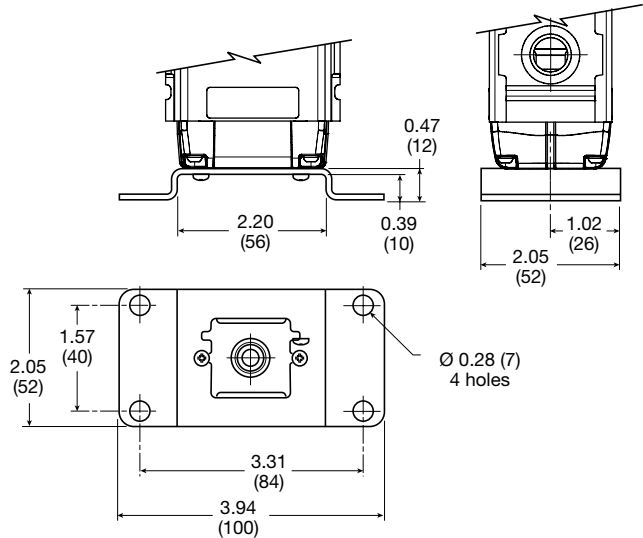

Cables

| Description | Part Number |
|--|---------------------|
| 2 mtr. cable with moulded straight M12x1 connector | CB-M12-4P-2M |

Most popular.

| |
|------------------------|
| B |
| Global Air Preparation |
| Introduction |
| Filters |
| Coalescers |
| Regulators |
| Filter / Regulators |
| Lubricators |
| Combinations |
| Accessories and Kits |



Dimensional Data

P32P

Dimensions inches (mm)

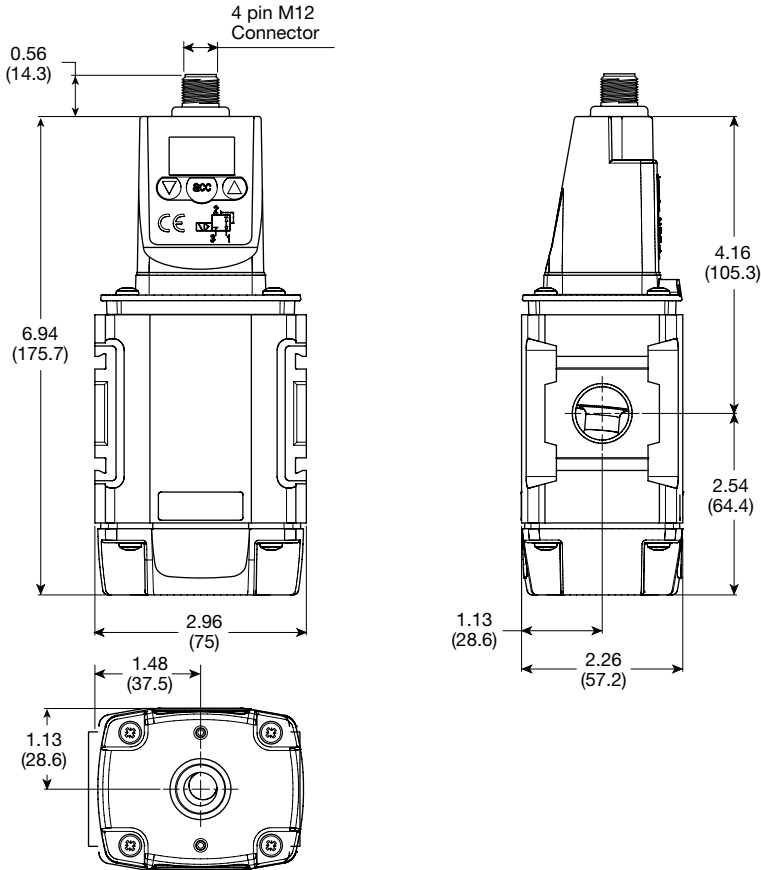

L-Bracket
P3KKA00ML

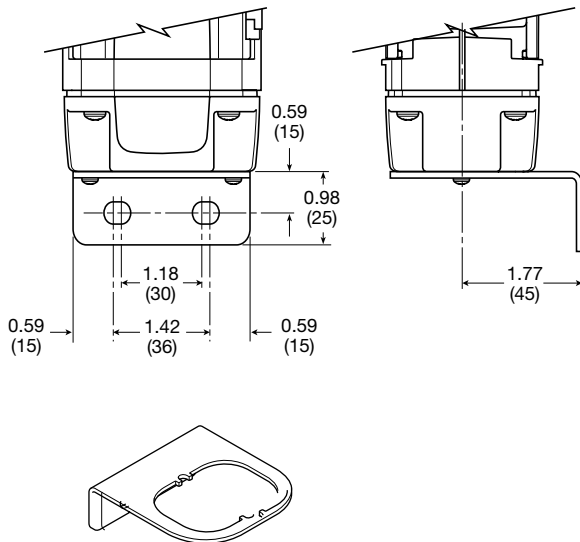

Foot Bracket
P3KKA00MC

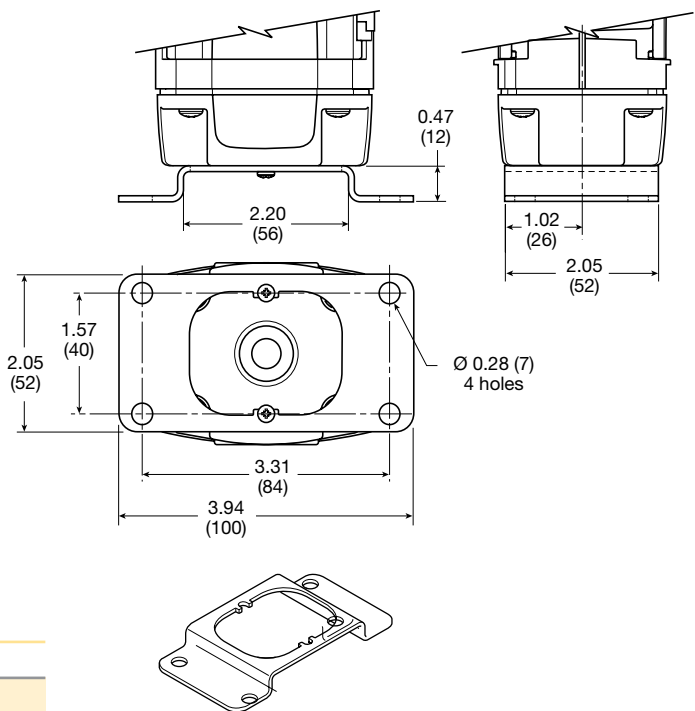

Cables

| Description | Part Number |
|--|---------------------|
| 2 mtr. cable with moulded straight M12x1 connector | CB-M12-4P-2M |

Most popular.

P31 Filter / Regulators - Mini

- Integral 1/4" ports (NPT, BSPP & BSPT)
- High efficiency 5 micron element as standard
- Excellent water removal efficiency
- Robust but lightweight aluminum construction
- Positive bayonet latch to ensure correct & safe fitting
- Secondary pressure ranges
- Secondary aspiration plus balanced poppet provides quick response and accurate pressure regulation

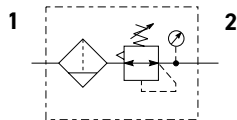

Operating information

| | | |
|---------------------------|----------------------------------|--------------------------------------|
| Flow capacity*: | 1/4 | 73 scfm (35 dm ³ /s, ANR) |
| Operating temperature†: | Plastic bowl | 14°F to 125°F (-10°C to 52°C) |
| | Metal bowl | 14°F to 150°F (-10°C to 65.5°C) |
| Supply pressure (max): | Plastic bowl | 150 psig (10 bar) |
| | Metal bowl | 250 psig (17 bar) |
| Standard filtration | 5 micron | |
| Useful retention‡: | 0.4 US oz. (12 cm ³) | |
| Adjusting range pressure: | 0 to 30 psig (0 to 2 bar) | |
| | 0 to 60 psig (0 to 4 bar) | |
| | 0 to 125 psig (0 to 8 bar) | |
| | 0 to 250 psig (0 to 17 bar) | |
| Weight: | 0.42 lb (0.19 kg) | |

* Inlet pressure 145 psig (10 bar). Secondary pressure 100 psig (6.9 bar) and 14.5 psig (1 bar) pressure drop.
 † Units with square gauges: 5°F to 150°F (-15°C to 65.5°C)
 ‡ Useful retention refers to volume below the quiet zone baffle.

Gauge supplied with every part. Gauge can be installed on the front or back of the regulator. If no gauge is installed, both seal screws must be installed.

| Port Size | Description (Relieving) | Bowl / Drain Type † | Part Number |
|-----------|-------------------------|---------------------|-----------------------|
| 1/4" | 125 psig (8 bar) | Poly / Manual | P31EB92EGMBN5P |
| 1/4" | 125 psig (8 bar) | Poly / Pulse | P31EB92EGBBN5P |
| 1/4" | 125 psig (8 bar) | Metal / Manual | P31EB92EMMBN5P |
| 1/4" | 125 psig (8 bar) | Metal / Pulse | P31EB92EMBBN5P |

† For polycarbonate bowl, see caution in Engineering Section A.

Air quality: **Within ISO 8573-1: 1991 Class 3 (Particulates)**
Within ISO 8573-1: 2001 Class 6 (Particulates)

Ordering Information:

P31EB 9 2 E G M B N 5 P

| Basic Series Global Modular Mini Filter / Regulator P31EB | Thread Type BSPP 1 BSPT 2 NPT 9 | Element 5µ Element E | Port Size 1/4 2 | Bowl Type Poly Bowl with Bowl Guard G Metal Bowl without Sight Gauge M | Adjustment N Non-Rising Knob | Mounting P Plastic Panel Mount Nut | | | | | | | | | | | | | | | |
|---|---|---------------------------------------|---------------------------|---|---|--|------|-----|-----|---------|--------|----------|--------|-------|---------|---------|-------|---------|----------------------|---------------------|----------------------|
| | | | | | Relief B Relieving N Non-Relieving | | | | | | | | | | | | | | | | |
| | | | | | | Adjustment Range With Square Gauge | | | | | | | | | | | | | | | |
| | | | | | | <table border="1"> <thead> <tr> <th>psig</th> <th>Bar</th> <th>MPa</th> </tr> </thead> <tbody> <tr> <td>1 = 30*</td> <td>V = 2*</td> <td>2 = 0.2*</td> </tr> <tr> <td>3 = 60</td> <td>S = 4</td> <td>4 = 0.4</td> </tr> <tr> <td>5 = 125</td> <td>T = 8</td> <td>6 = 0.8</td> </tr> <tr> <td>7[§] = 232</td> <td>W[§] = 16</td> <td>8[§] = 1.6</td> </tr> </tbody> </table> | psig | Bar | MPa | 1 = 30* | V = 2* | 2 = 0.2* | 3 = 60 | S = 4 | 4 = 0.4 | 5 = 125 | T = 8 | 6 = 0.8 | 7 [§] = 232 | W [§] = 16 | 8 [§] = 1.6 |
| psig | Bar | MPa | | | | | | | | | | | | | | | | | | | |
| 1 = 30* | V = 2* | 2 = 0.2* | | | | | | | | | | | | | | | | | | | |
| 3 = 60 | S = 4 | 4 = 0.4 | | | | | | | | | | | | | | | | | | | |
| 5 = 125 | T = 8 | 6 = 0.8 | | | | | | | | | | | | | | | | | | | |
| 7 [§] = 232 | W [§] = 16 | 8 [§] = 1.6 | | | | | | | | | | | | | | | | | | | |
| | | | | | | Drain Type Pulse Drain B Manual Drain M | | | | | | | | | | | | | | | |

* Regulator comes with gauge respective to the adjustment range available.
 § Not available with poly bowl with bowl guard.

□ Most popular.

Mini Filter / Regulators

Material Specifications

| | |
|--------------------|---------------------------|
| Body | Aluminum |
| Adjustment knob | Acetal |
| Bonnet | Glass-filled nylon |
| Plastic bowl | Polycarbonate |
| Metal bowl | Aluminum |
| Bowl guard | Nylon |
| Filter element | Polyethylene |
| Seals | Nitrile |
| Springs | Steel |
| Valve assembly | Acetal / Nitrile |
| Diaphragm assembly | Stainless Steel / Nitrile |
| Panel nut | Acetal |

Repair and Service Kits

| | |
|--|-------------------|
| Plastic bowl / bowl guard manual drain | P31KB00BGM |
| Plastic bowl / bowl guard pulse drain | P31KB00BGB |
| Metal bowl / w/o sight gauge pulse drain | P31KB00BMB |
| 5µ particle filter element | P31KA00ESE |
| Panel mount nut - aluminum | P31KA00MM |
| Panel mount nut - plastic | P31KA00MP |
| Angle bracket (attaches via panel nut) | P31KB00MR |
| C-bracket (fits to body) | P31KA00MW |
| T-bracket with body connector | P31KA00MT |
| Body connector | P31KA00CB |

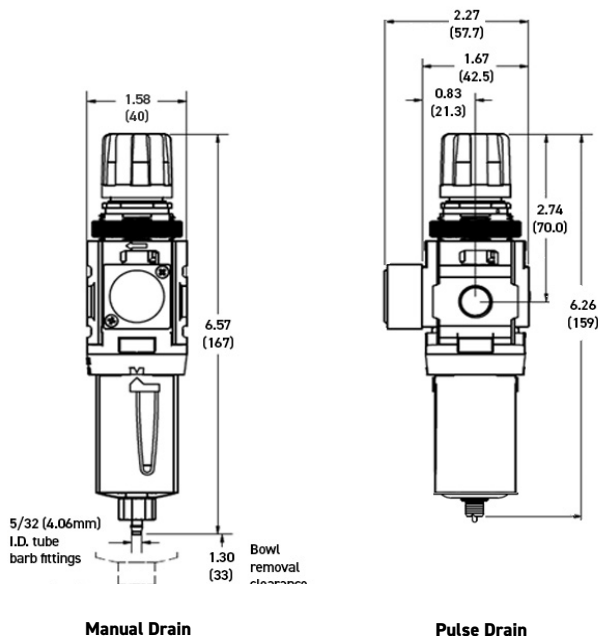

WARNING

**Product rupture can cause serious injury.
Do not connect regulator to bottled gas.
Do not exceed Maximum primary pressure rating.**

Air Preparation Products Global Air Preparation

Flow Charts

P31EB 1/4" Filter / Regulator

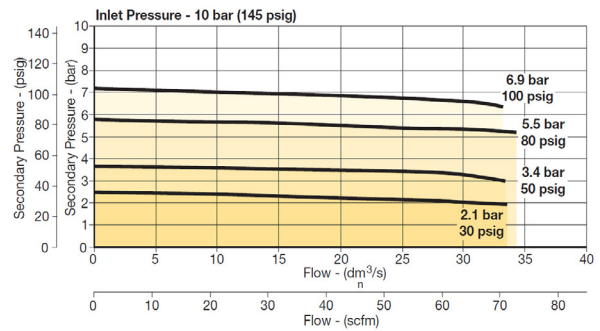

Gauges (*see note below)

| | | |
|---|--------------------------|--------------------|
| Square flush mount gauge | 0-60 psig | P31KA060XB |
| | 0-160 psig | P31KA160XB |
| | 0-290 psig | P31KA290XB |
| | 0-4 bar | P31KA04BXB |
| | 0-11 bar | P31KA11BXB |
| | 0-20 bar | P31KA20BXB |
| | 0-0.4 MPa | P31KA04MXB |
| | 0-1.1 MPa | P31KA11MXB |
| | 0-2.0 MPa | P31KA20MXB |
| | Square flush mount gauge | 0-4 bar |
| 0-11 bar | | K4511SCR11B |
| 0-60 psig | | K4511SCR060 |
| 0-160 psig | | K4511SCR160 |
| Square with adapter kit | 0-4 bar | P6G-PR10040 |
| | 0-11 bar | P6G-PR10110 |
| | 0-60 psig | P6G-PR90060 |
| | 0-160 psig | P6G-PR90160 |
| 1.00" Round 1/8" center back mount | 0-60 psig / 1-4 bar | K4510N18060 |
| | 0-160 psig / 0-11 bar | K4510N18160 |
| 40mm Round 1/8" center back mount (not for use with common port regulators) | 0-30 psig / 0-2 bar | K4515N18030 |
| | 0-60 psig / 0-4 bar | K4515N18060 |
| | 0-160 psig / 0-11 bar | K4515N18160 |
| | 0-60 psig | P31KA060XB |

For best performance, regulated pressure should always be set by increasing the pressure up to the desired setting.

***For P31 Regulators with date code after November 2023 (4423 Date Code), please use these part numbers when ordering a replacement gauge.**

CAUTION:

REGULATOR PRESSURE ADJUSTMENT – The working range of knob adjustment is designed to permit outlet pressures within their full range. Pressure adjustment beyond this range is also possible because the knob is not a limiting device. This is a common characteristic of most industrial regulators, and limiting devices may be obtained only by special design. For best performance, regulated pressure should always be set by increasing the pressure up to the desired setting.



P32 Filter / Regulators - Compact

- Integral 1/4", 3/8" or 1/2" ports (NPT, BSPP & BSPT)
- High efficiency 5 micron element as standard
- Excellent water removal efficiency
- Robust but lightweight aluminum construction
- Positive bayonet latch to ensure correct & safe fitting
- Secondary pressure ranges
- Secondary aspiration plus balanced poppet provides quick response and accurate pressure regulation

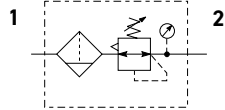

| Port Size | Description (Relieving) | Bowl / Drain Type † | Part Number |
|-----------|-------------------------|---------------------|-----------------------|
| 1/4" | 125 psig (8 bar) | Poly / Manual | P32EB92EGMBNGP |
| 1/4" | 125 psig (8 bar) | Poly / Auto | P32EB92EGABNGP |
| 1/4" | 125 psig (8 bar) | Metal / Manual | P32EB92ESMBNGP |
| 1/4" | 125 psig (8 bar) | Metal / Auto | P32EB92ESABNGP |
| 3/8" | 125 psig (8 bar) | Poly / Manual | P32EB93EGMBNGP |
| 3/8" | 125 psig (8 bar) | Poly / Auto | P32EB93EGABNGP |
| 3/8" | 125 psig (8 bar) | Metal / Manual | P32EB93ESMBNGP |
| 3/8" | 125 psig (8 bar) | Metal / Auto | P32EB93ESABNGP |
| 1/2" | 125 psig (8 bar) | Poly / Manual | P32EB94EGMBNGP |
| 1/2" | 125 psig (8 bar) | Poly / Auto | P32EB94EGABNGP |
| 1/2" | 125 psig (8 bar) | Metal / Manual | P32EB94ESMBNGP |
| 1/2" | 125 psig (8 bar) | Metal / Auto | P32EB94ESABNGP |

Operating information

| | | |
|---------------------------|-----|---------------------------------------|
| Flow capacity*: | 1/4 | 166 scfm (78 dm ³ /s, ANR) |
| | 3/8 | 178 scfm (84 dm ³ /s, ANR) |
| | 1/2 | 178 scfm (84 dm ³ /s, ANR) |
| Operating temperature: | | |
| Plastic bowl | | -13°F to 125°F (-25°C to 52°C) |
| Metal bowl | | -13°F to 150°F (-25°C to 65.5°C) |
| Supply pressure (max): | | |
| Plastic bowl | | 150 psig (10 bar) |
| Metal bowl | | 250 psig (17 bar) |
| Standard filtration: | | 5 micron |
| Useful retention†: | | 1.7 US oz. (51 cm ³) |
| Adjusting range pressure: | | 0 to 30 psig (0 to 2 bar) |
| | | 0 to 60 psig (0 to 4 bar) |
| | | 0 to 125 psig (0 to 8 bar) |
| | | 0 to 250 psig (0 to 17 bar) |
| Gauge port (2 each): | | 1/4 NPT, BSPP, BSPT |
| Weight: | | 1.37 lb (0.62 kg) |

* Inlet pressure 145 psig (10 bar). Secondary pressure 80.0 psig (5.5 bar)
† Useful retention refers to volume below the quiet zone baffle.

Air quality: Within ISO 8573-1: 1991 Class 3 (Particulates)
Within ISO 8573-1: 2001 Class 6 (Particulates)

† For polycarbonate bowl, see caution in Engineering Section A.

Ordering Information:

| | | | | | | | | | |
|--|---|---|-----------------------------------|--|---|--|---|--|--|
| P32EB | 9 | 2 | E | G | M | B | N | G | P |
| Basic Series Global Modular Compact Filter / Regulator P32EB | Thread Type BSPP 1 BSPT 2 NPT 9 | Port Size 1/4 2 3/8 3 1/2 4 | Element 5µ E Element | Bowl Type Poly Bowl with Bowl Guard G Metal Bowl without Sight Gauge M Metal Bowl with Sight Gauge S | Drain Type Manual Drain M Auto Drain A | Adjustment N Non-Rising Knob | Relief B Relieving N Non-Relieving | Adjustment Range With Round Gauge Z 30 psig; 2 Bar; 0.2 MPa M 60 psig; 4 Bar; 0.4 MPa G 125 psig; 8 Bar; 0.8 MPa J [§] 250 psig; 17 Bar; 1.7 MPa Without Gauge Y 30 psig; 2 Bar; 0.2 MPa L 60 psig; 4 Bar; 0.4 MPa N 125 psig; 8 Bar; 0.8 MPa H [§] 250 psig; 17 Bar; 1.7 MPa | Mounting P Plastic Panel Mount Nut |

Most popular.

* Regulator comes with gauge respective to the adjustment range selected.
§ Not available with poly bowl with bowl guard.

Global Air Preparation
Introduction
Filters
Coalescers
Regulators
Filter / Regulators
Lubricators
Combinations
Accessories and Kits



Compact Filter / Regulators

Air Preparation Products Global Air Preparation

Material Specifications

| | |
|---------------------------|--------------------------|
| Body | Aluminum |
| Adjustment knob | Acetal |
| Element retainer / baffle | Acetal |
| Plastic bowl | Polycarbonate |
| Metal bowl | Aluminum |
| Bowl guard | Nylon |
| Filter element | Sintered polyethylene |
| Seals | Nitrile |
| Springs | Steel, stainless steel |
| Valve assembly | Acetal / nitrile |
| Diaphragm assembly | Nitrile /Stainless steel |
| Panel nut | Acetal |
| Sight gauge | Nylon |

Repair and Service Kits

| | |
|---|-------------------|
| Plastic bowl / bowl guard manual drain | P32KB00BGM |
| Metal bowl / sight gauge manual drain | P32KB00BSM |
| Auto drain | P32KA00DA |
| 5µ particle filter element | P32KA00ESE |
| Panel mount nut - aluminum | P32KA00MM |
| Panel mount nut - plastic | P32KA00MP |
| Angle bracket (fits to panel mount threads) | P32KB00MR |
| T-bracket (fits to body connector) | P32KA00MB |
| T-bracket with body connector | P32KA00MT |
| Body connector | P32KA00CB |

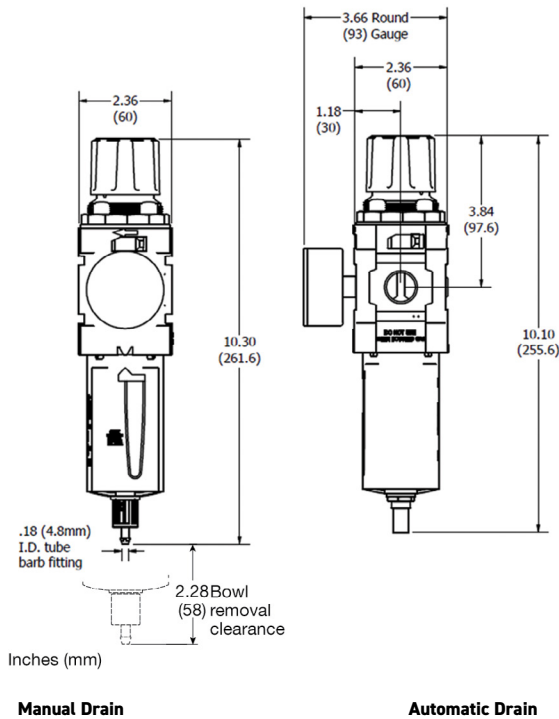

Flow Charts

P32EB 1/4" Filter / Regulator

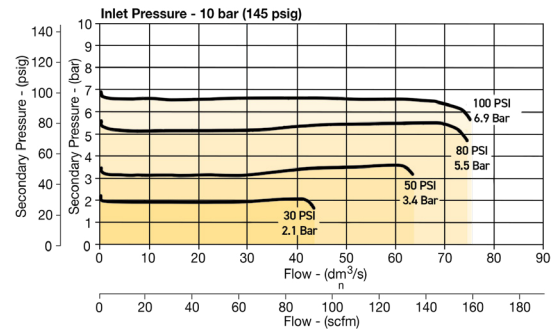

P32EB3/8" Filter/Regulator

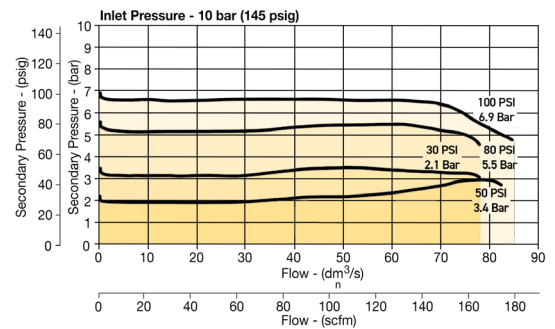

P32EB 1/2" Filter/Regulator

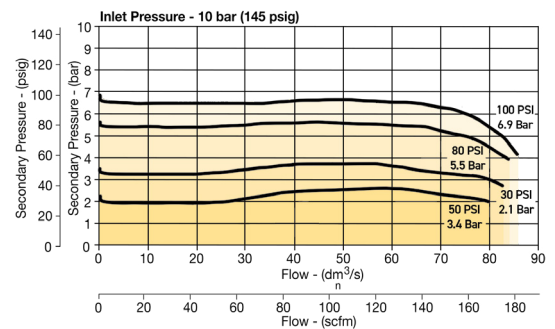

⚠ WARNING

**Product rupture can cause serious injury.
Do not connect regulator to bottled gas.
Do not exceed Maximum primary pressure rating.**

CAUTION:

REGULATOR PRESSURE ADJUSTMENT – The working range of knob adjustment is designed to permit outlet pressures within their full range. Pressure adjustment beyond this range is also possible because the knob is not a limiting device. This is a common characteristic of most industrial regulators, and limiting devices may be obtained only by special design. For best performance, regulated pressure should always be set by increasing the pressure up to the desired setting.

Gauges

| | | |
|------------------------|-----------------------|--------------------|
| 50mm (2") round | 0-30 psig / 0-2 bar | K4520N14030 |
| 1/4" center back mount | 0-60 psig / 0-4 bar | K4520N14060 |
| | 0-160 psig / 0-11 bar | K4520N14160 |
| | 0-300 psig / 0-20 bar | K4520N14300 |

For best performance, regulated pressure should always be set by increasing the pressure up to the desired setting.

P33 Filter / Regulators - Standard

- Integral 1/2" or 3/4" ports (NPT, BSPP & BSPT)
- High efficiency 5 micron element as standard
- Excellent water removal efficiency
- Robust but lightweight aluminum construction
- Positive bayonet latch to ensure correct & safe fitting
- Secondary pressure ranges
- Secondary aspiration plus balanced poppet provides quick response and accurate pressure regulation

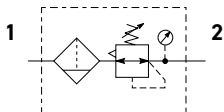

| Port Size | Description / Relieving | Bowl / Drain Type † | Part Number |
|-----------|-------------------------|---------------------|-----------------------|
| 1/2" | 125 psig (8 bar) | Poly / Manual | P33EA94EGMBNGP |
| 1/2" | 125 psig (8 bar) | Poly / Auto | P33EA94EGABNGP |
| 1/2" | 125 psig (8 bar) | Metal / Manual | P33EA94ESMBNGP |
| 1/2" | 125 psig (8 bar) | Metal / Auto | P33EA94ESABNGP |
| 3/4" | 125 psig (8 bar) | Poly / Manual | P33EA96EGMBNGP |
| 3/4" | 125 psig (8 bar) | Poly / Auto | P33EA96EGABNGP |
| 3/4" | 125 psig (8 bar) | Metal / Manual | P33EA96ESMBNGP |
| 3/4" | 125 psig (8 bar) | Metal / Auto | P33EA96ESABNGP |

† For polycarbonate bowl, see caution in Engineering Section A.

Operating information

| | | |
|---------------------------|--|--|
| Flow capacity*: | 1/2 | 200 scfm (94 dm ³ /s, ANR) |
| | 3/4 | 235 scfm (109 dm ³ /s, ANR) |
| Operating temperature: | -13°F to 125°F (-25°C to 52°C) | |
| | Metal bowl: -13°F to 150°F (-25°C to 65.5°C) | |
| Supply pressure (max): | Plastic bowl: 150 psig (10 bar) | |
| | Metal bowl: 250 psig (17 bar) | |
| Standard filtration: | 5 micron | |
| Useful retention†: | 2.8 US oz. (85 cm ³) | |
| Adjusting range pressure: | 0 to 30 psig (0 to 2 bar) | |
| | 0 to 60 psig (0 to 4 bar) | |
| | 0 to 125 psig (0 to 8 bar) | |
| | 0 to 250 psig (0 to 17 bar) | |
| Gauge port (2 each): | 1/4 NPT, BSPP, BSPT | |
| Weight: | 1.87 lbs (0.85 kg) | |

* Inlet pressure 145 psig (10 bar). Secondary pressure 91.3 psig (6.3 bar) and 14.5 psig (1 bar) pressure drop.

† Useful retention refers to volume below the quiet zone baffle.

Air quality: Within ISO 8573-1: 1991 Class 3 (Particulates)
Within ISO 8573-1: 2001 Class 6 (Particulates)

Ordering Information:

| P33EA 9 6 E G M B N G P | | | | | | | | | | | | | | | | | | | | | | | | | | | | | |
|--|---|--------------------------------|------------------------------------|--|--|---|---|--|--|------------------|--|---|-------------------------|---|-------------------------|---|--------------------------|----------------|---------------------------|---------------|--|---|-------------------------|---|-------------------------|---|--------------------------|----------------|---------------------------|
| Basic Series Global Modular Standard Filter / Regulator P33EA | Thread Type BSPP 1 BSPT 2 NPT 9 | Element 5µ E Element | Port Size 1/2 4 3/4 6 | Bowl Type Poly Bowl with Bowl Guard G Metal Bowl without Sight Gauge M Metal Bowl with Sight Gauge S | Adjustment N Non-Rising Knob | Relief B Relieving N Non-Relieving | Drain Type M Manual Drain A Auto Drain | Adjustment Range | Mounting P Plastic Panel Mount Nut | | | | | | | | | | | | | | | | | | | | |
| | | | | | | | | <table border="1"> <thead> <tr> <th colspan="2">With Round Gauge</th> </tr> </thead> <tbody> <tr> <td>Z</td> <td>30 psig; 2 Bar; 0.2 MPa</td> </tr> <tr> <td>M</td> <td>60 psig; 4 Bar; 0.4 MPa</td> </tr> <tr> <td>G</td> <td>125 psig; 8 Bar; 0.8 MPa</td> </tr> <tr> <td>J[§]</td> <td>250 psig; 17 Bar; 1.7 MPa</td> </tr> <tr> <th colspan="2">Without Gauge</th> </tr> <tr> <td>Y</td> <td>30 psig; 2 Bar; 0.2 MPa</td> </tr> <tr> <td>L</td> <td>60 psig; 4 Bar; 0.4 MPa</td> </tr> <tr> <td>N</td> <td>125 psig; 8 Bar; 0.8 MPa</td> </tr> <tr> <td>H[§]</td> <td>250 psig; 17 Bar; 1.7 MPa</td> </tr> </tbody> </table> | | With Round Gauge | | Z | 30 psig; 2 Bar; 0.2 MPa | M | 60 psig; 4 Bar; 0.4 MPa | G | 125 psig; 8 Bar; 0.8 MPa | J [§] | 250 psig; 17 Bar; 1.7 MPa | Without Gauge | | Y | 30 psig; 2 Bar; 0.2 MPa | L | 60 psig; 4 Bar; 0.4 MPa | N | 125 psig; 8 Bar; 0.8 MPa | H [§] | 250 psig; 17 Bar; 1.7 MPa |
| With Round Gauge | | | | | | | | | | | | | | | | | | | | | | | | | | | | | |
| Z | 30 psig; 2 Bar; 0.2 MPa | | | | | | | | | | | | | | | | | | | | | | | | | | | | |
| M | 60 psig; 4 Bar; 0.4 MPa | | | | | | | | | | | | | | | | | | | | | | | | | | | | |
| G | 125 psig; 8 Bar; 0.8 MPa | | | | | | | | | | | | | | | | | | | | | | | | | | | | |
| J [§] | 250 psig; 17 Bar; 1.7 MPa | | | | | | | | | | | | | | | | | | | | | | | | | | | | |
| Without Gauge | | | | | | | | | | | | | | | | | | | | | | | | | | | | | |
| Y | 30 psig; 2 Bar; 0.2 MPa | | | | | | | | | | | | | | | | | | | | | | | | | | | | |
| L | 60 psig; 4 Bar; 0.4 MPa | | | | | | | | | | | | | | | | | | | | | | | | | | | | |
| N | 125 psig; 8 Bar; 0.8 MPa | | | | | | | | | | | | | | | | | | | | | | | | | | | | |
| H [§] | 250 psig; 17 Bar; 1.7 MPa | | | | | | | | | | | | | | | | | | | | | | | | | | | | |
| § Not available with poly bowl with bowl guard. | | | | | | | | | | | | | | | | | | | | | | | | | | | | | |

Most popular.

Global Air Preparation

Introduction

Filters

Coalescers

Regulators

Filter / Regulators

Lubricators

Combinations

Accessories and Kits



Standard Filter / Regulators

Material Specifications

| | |
|---------------------------|------------------------|
| Body | Aluminum |
| Adjustment knob | Acetal |
| Body cap | ABS |
| Element retainer / baffle | Acetal |
| Plastic bowl | Polycarbonate |
| Metal bowl | Aluminum |
| Filter element | Sintered |
| Polyethylene | |
| Seals | Nitrile |
| Springs | Steel, stainless steel |
| Valve assembly | Brass / nitrile |
| Diaphragm assembly | Nitrile / zinc |
| Panel nut | Acetal |
| Sight gauge | Nylon |

Repair and Service Kits

| | |
|---|-------------------|
| Plastic bowl / bowl guard, manual drain | P33KA00BGM |
| Metal bowl / sight gauge, manual drain | P33KA00BSM |
| Auto drain | P32KA00DA |
| 5µ particle filter element | P33KA00ESE |
| Diaphragm repair kit - Relieving | P33KA00RB |
| Diaphragm repair kit - Non-relieving | P33KA00RC |
| Panel mount nut - Aluminum | P33KA00MM |
| Panel mount nut - Plastic | P33KA00MP |
| Angle bracket (fits to panel mount threads) | P33KA00MR |
| T-bracket (fits to body connector) | P32KA00MB |
| T-bracket with body connector | P32KA00MT |
| Body connector | P32KA00CB |

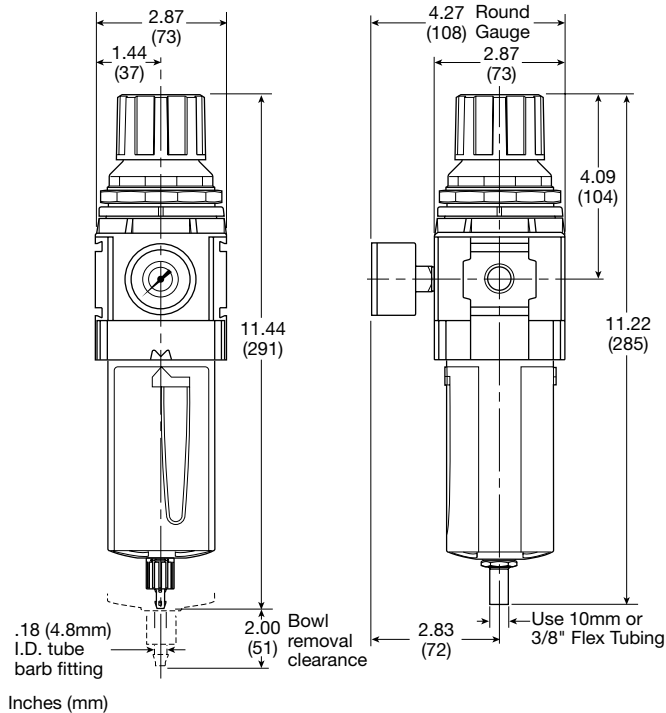

Manual Drain

Automatic Drain

Air Preparation Products Global Air Preparation

Flow Charts

P33EA 1/2" Filter / Regulator

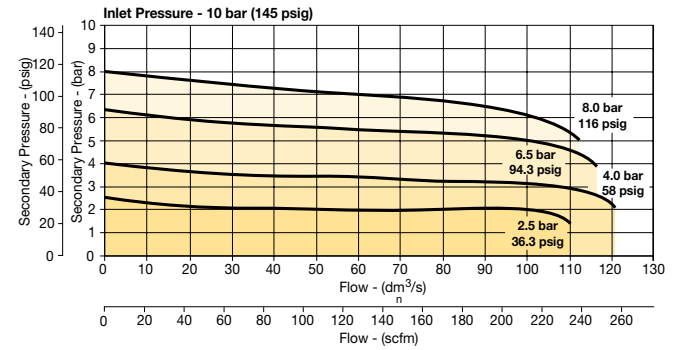

P33EA 3/4" Filter/Regulator

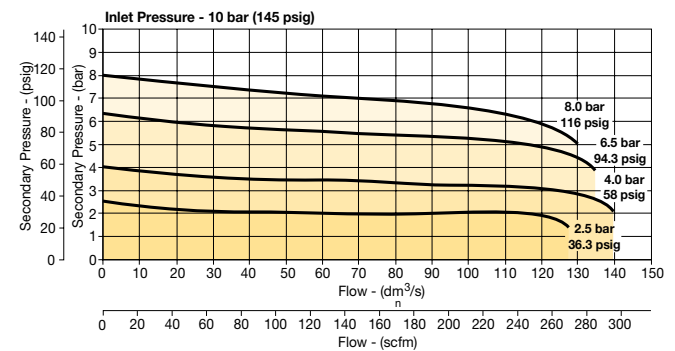

WARNING

Product rupture can cause serious injury.
Do not connect regulator to bottled gas.
Do not exceed Maximum primary pressure rating.

CAUTION:

REGULATOR PRESSURE ADJUSTMENT – The working range of knob adjustment is designed to permit outlet pressures within their full range. Pressure adjustment beyond this range is also possible because the knob is not a limiting device. This is a common characteristic of most industrial regulators, and limiting devices may be obtained only by special design. For best performance, regulated pressure should always be set by increasing the pressure up to the desired setting.

Gauges

| | | |
|------------------------|-----------------------|--------------------|
| 50mm (2") round | 0-30 psig / 0-2 bar | K4520N14030 |
| 1/4" center back mount | 0-60 psig / 0-4 bar | K4520N14060 |
| | 0-160 psig / 0-11 bar | K4520N14160 |
| | 0-300 psig / 0-20 bar | K4520N14300 |

For best performance, regulated pressure should always be set by increasing the pressure up to the desired setting.



Mini Lubricators

P31 Lubricators - Mini

- Integral 1/4" ports (NPT, BSPP & BSPT)
- Robust but lightweight aluminum construction
- Proportional oil delivery over a wide range of air flows
- Finger tip ratchet control for precise oil drip rate adjustment

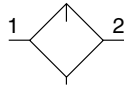

Lubricator with drain

| Port Size | Description † | Part Number |
|-----------|-----------------------|--------------------|
| 1/4" | Poly Bowl - No Drain | P31LB92LGNN |
| 1/4" | Metal Bowl - No Drain | P31LB92LMNN |

† For polycarbonate bowl, see caution in Engineering Section A.

Operating information

Flow capacity*:
1/4 52 scfm (25 dm³/s, ANR)

Operating temperature:
Plastic bowl 14°F to 125°F (-10°C to 52°C)
Metal bowl 14°F to 150°F (-10°C to 65.5°C)

Supply pressure (max):
Plastic bowl 150 psig (10 bar)
Metal bowl 250 psig (17 bar)

Bowl capacity: 0.6 US oz. (18 cm³)

Weight: 0.29 lb (0.13 kg)

* Inlet pressure 91.3 psig (6.3 bar). Pressure drop 4.9 psig (0.34 bar).

Ordering Information:

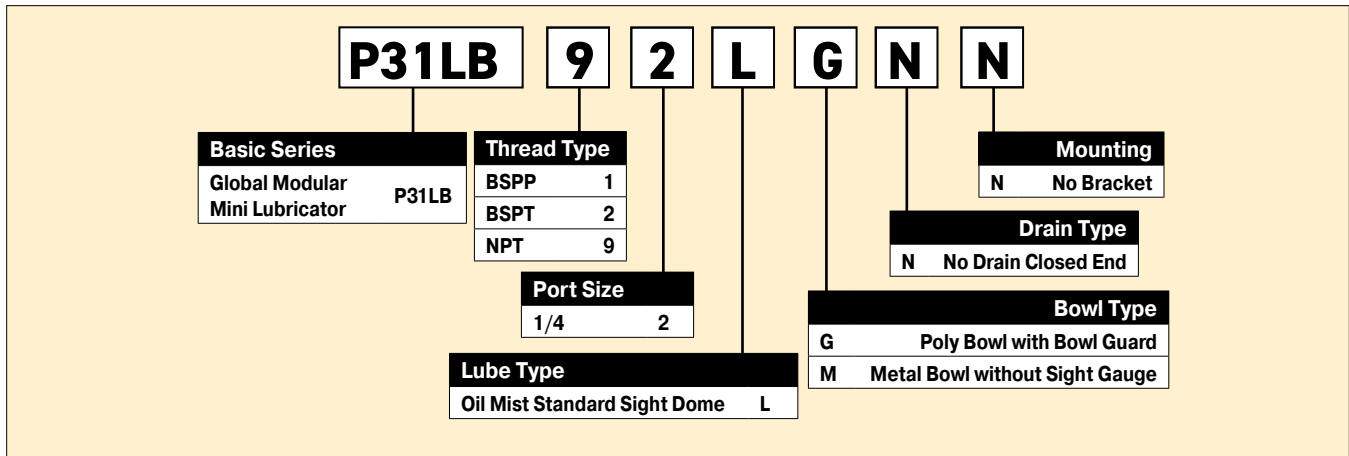

Suggested Lubricant **F442 Oil**

Petroleum based oil of 100 to 200 SUS viscosity at 100°F (38°C) and an aniline point greater than 200°F (93°C)
(DO NOT USE OILS WITH ADDITIVES, COMPOUNDED OILS CONTAINING SOLVENTS, GRAPHITE, DETERGENTS, OR SYNTHETIC OILS.)

Most popular.

B
Global Air Preparation

Introduction

Filters

Coalescers

Regulators

Filter / Regulators

Lubricators

Combinations

Accessories and Kits



Mini Lubricators

Material Specifications

| | |
|---------------------|-----------------|
| Body | Aluminum |
| Body cap | ABS |
| Plastic bowl | Polycarbonate |
| Metal bowl | Aluminum |
| Seals | Nitrile |
| Sight dome | Polycarbonate |
| Suggested lubricant | ISO / ASTM VG32 |
| Pick-up filter | Sintered bronze |

Repair and Service Kits

| | |
|---------------------------------------|-------------------|
| Plastic bowl / bowl guard no drain | P31KB00BGN |
| Metal bowl / w/o sight gauge no drain | P31KB00BMN |
| Drip control assembly | P32KA00PG |
| Fill plug | P31KA00PL |
| C-bracket (fits to body) | P31KA00MW |
| T-bracket with body connector | P31KA00MT |
| Body connector | P31KA00CB |
| Oil (1 quart) | F442001 |
| Oil (1 gallon) | F442002 |
| Oil (12 quart case) | F442003 |
| Oil (4 gallon case) | F442005 |

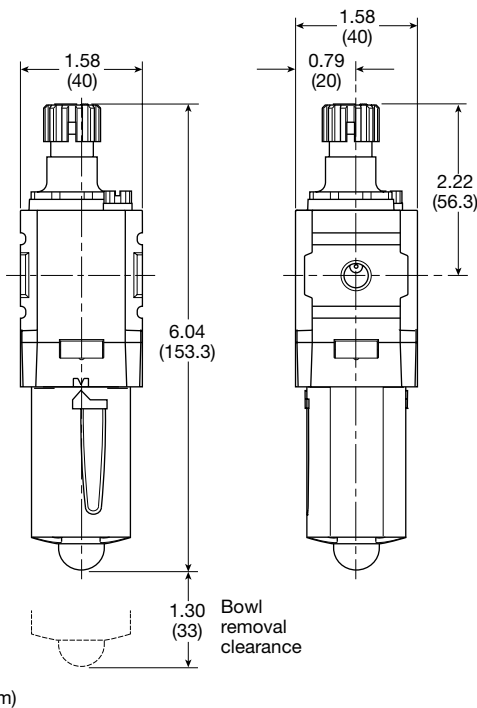

Air Preparation Products Global Air Preparation

Flow Charts

P31LB 1/4" Lubricator

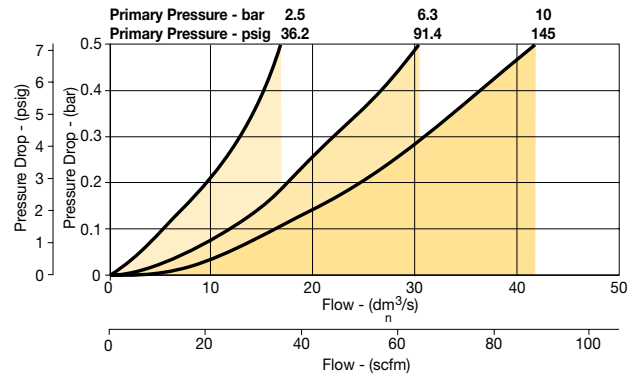

B

Global Air
Preparation

Introduction

Filters

Coalescers

Regulators

Filter /
Regulators

Lubricators

Combinations

Accessories
and Kits



P32 Lubricators - Compact

- Integral 1/4", 3/8" or 1/2" ports (NPT, BSPP & BSPT)
- Robust but lightweight aluminum construction
- Proportional oil delivery over a wide range of air flows
- Finger tip ratchet control for precise oil drip rate adjustment
- Fill from top under system pressure

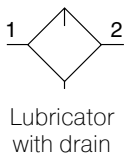

Operating information

| | |
|--|--------------------------------------|
| Flow capacity*: | |
| 1/4 | 38 scfm (17 dm ³ /s, ANR) |
| 3/8 | 70 scfm (33 dm ³ /s, ANR) |
| 1/2 | 90 scfm (42 dm ³ /s, ANR) |
| Operating temperature: | |
| Plastic bowl | 14°F to 125°F (-10°C to 52°C) |
| Metal bowl | 14°F to 150°F (-10°C to 65.5°C) |
| Supply pressure (max): | |
| Plastic bowl | 150 psig (10 bar) |
| Metal bowl | 250 psig (17 bar) |
| Bowl capacity: | 4.09 US oz. (121 cm ³) |
| Weight: | 0.68 lb (0.31 kg) |
| * Inlet pressure 91.3 psig (6.3 bar). Pressure drop 4.9 psig (0.34 bar). | |

| Port Size | Description † | Part Number |
|-----------|-----------------------|--------------------|
| 1/4" | Poly Bowl - No Drain | P32LB92LGNN |
| 1/4" | Metal Bowl - No Drain | P32LB92LSNN |
| 3/8" | Poly Bowl - No Drain | P32LB93LGNN |
| 3/8" | Metal Bowl - No Drain | P32LB93LSNN |
| 1/2" | Poly Bowl - No Drain | P32LB94LGNN |
| 1/2" | Metal Bowl - No Drain | P32LB94LSNN |

† For polycarbonate bowl, see caution in Engineering Section A.

Ordering Information:

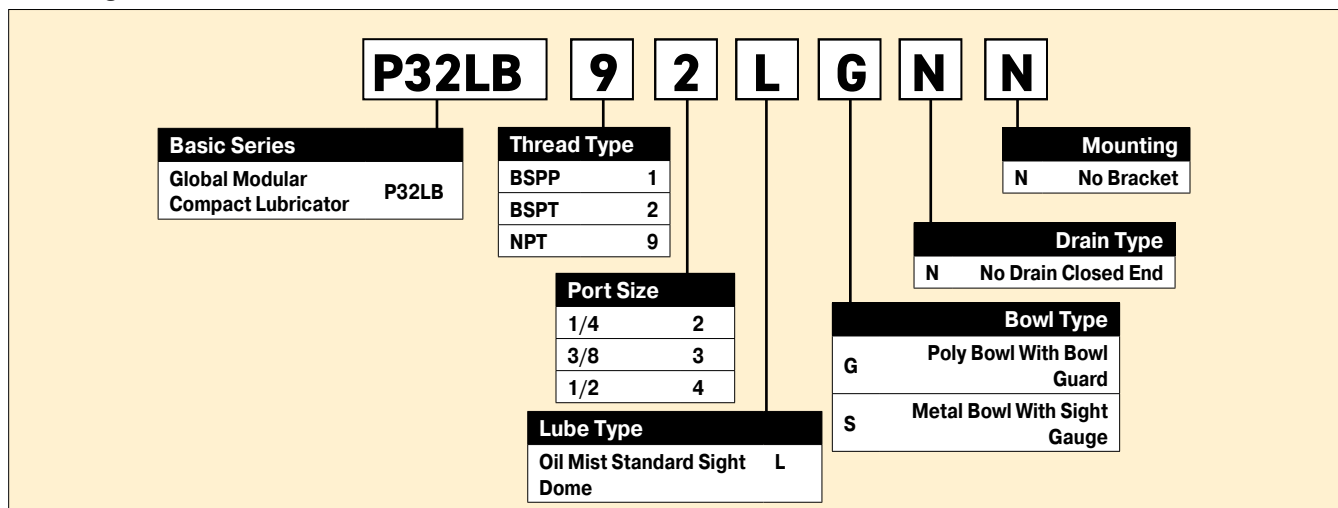

Suggested Lubricant **F442 Oil**
 Petroleum based oil of 100 to 200 SUS viscosity at 100°F (38°C) and an aniline point greater than 200°F (93°C)
 (DO NOT USE OILS WITH ADDITIVES, COMPOUNDED OILS CONTAINING SOLVENTS, GRAPHITE, DETERGENTS, OR SYNTHETIC OILS.)

Most popular.

P
 Global Air Preparation
 Introduction
 Filters
 Coalescers
 Regulators
 Filter / Regulators
 Lubricators
 Combinations
 Accessories and Kits



Compact Lubricators

Material Specifications

| | |
|---------------------|-----------------|
| Body | Aluminum |
| Body cap | ABS |
| Plastic bowl | Polycarbonate |
| Metal bowl | Aluminum |
| Seals | Nitrile |
| Sight dome | Polycarbonate |
| Sight gauge | Nylon |
| Suggested lubricant | ISO / ASTM VG32 |
| Pick-up filter | Sintered bronze |

Repair and Service Kits

| | |
|---------------------------------------|-------------------|
| Plastic bowl / bowl guard no drain | P32KB00BGN |
| Metal bowl / w/o sight gauge no drain | P32KB00BMN |
| Metal bowl / Sight gauge no drain | P32KB00BSN |
| Drip control assembly | P32KA00PG |
| Fill plug | P32KA00PL |
| L-bracket (fits to body) | P32KA00ML |
| T-bracket (fits to body connector) | P32KA00MB |
| T-bracket with body connector | P32KA00MT |
| Body connector | P32KA00CB |
| Oil (1 quart) | F442001 |
| Oil (1 gallon) | F442002 |
| Oil (12 quart case) | F442003 |
| Oil (4 gallon case) | F442005 |

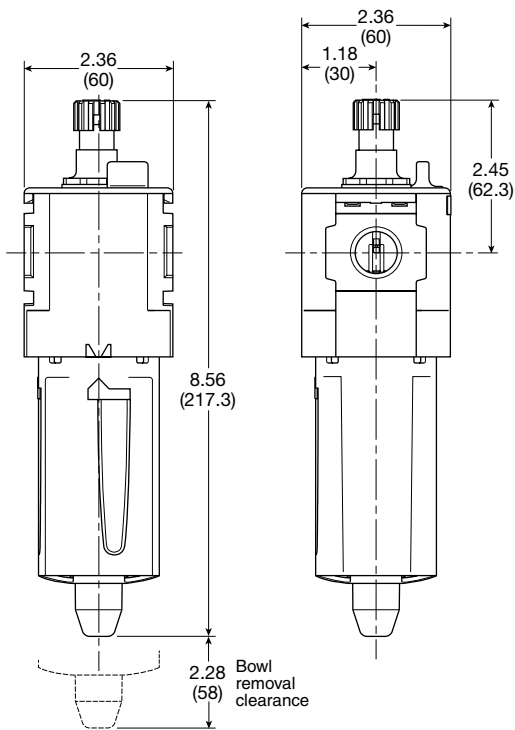

Inches (mm)

Air Preparation Products Global Air Preparation

Flow Charts

P32LB 1/4" Lubricator

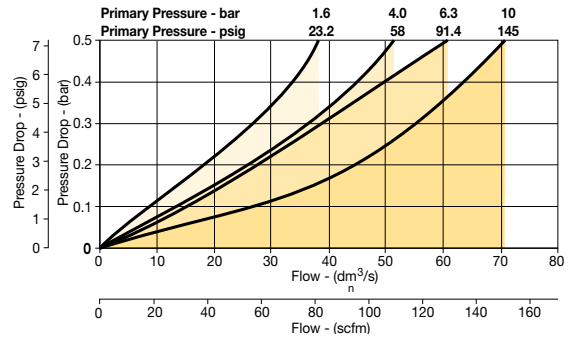

P32LB 3/8" Lubricator

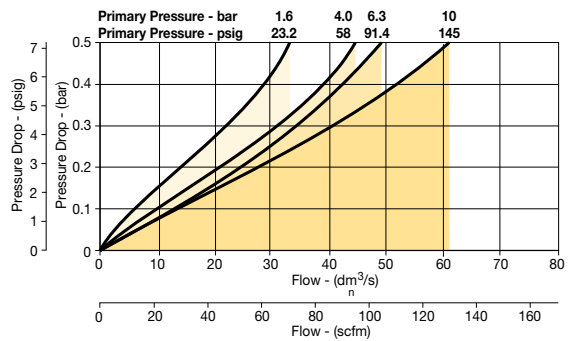

P32LB 1/2" Lubricator

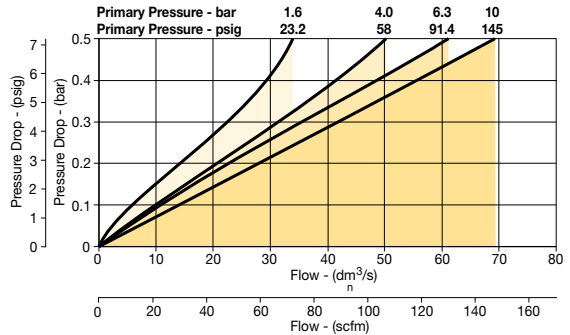

B

Global Air
Preparation

Introduction

Filters

Coalescers

Regulators

Filter /
Regulators

Lubricators

Combinations

Accessories
and Kits



P33 Lubricators - Standard

- Integral 1/2" or 3/4" ports (NPT, BSPP & BSPT)
- Robust but lightweight aluminum construction
- Proportional oil delivery over a wide range of air flows
- Finger tip ratchet control for precise oil drip rate adjustment
- Fill from top under system pressure

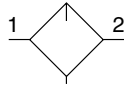

Lubricator with drain

Operating information

| | | |
|--|--------------|---------------------------------------|
| Flow capacity*: | 1/2 | 110 scfm (52 dm ³ /s, ANR) |
| | 3/4 | 150 scfm (71 dm ³ /s, ANR) |
| Operating temperature: | Plastic bowl | 14°F to 125°F (-10°C to 52°C) |
| | Metal bowl | 14°F to 150°F (-10°C to 65.5°C) |
| Supply pressure (max): | Plastic bowl | 150 psig (10 bar) |
| | Metal bowl | 250 psig (17 bar) |
| Bowl capacity: | | 6.1 US oz. (181 cm ³) |
| Weight: | | 1.04 lb (0.47 kg) |
| * Inlet pressure 91.3 psig (6.3 bar). Pressure drop 4.9 psig (0.34 bar). | | |

| Port Size | Description † | Part Number |
|-----------|-----------------------|--------------------|
| 1/2" | Poly Bowl - No Drain | P33LA94LGNN |
| 1/2" | Metal Bowl - No Drain | P33LA94LSNN |
| 3/4" | Poly Bowl - No Drain | P33LA96LGNN |
| 3/4" | Metal Bowl - No Drain | P33LA96LSNN |

† For polycarbonate bowl, see caution in Engineering Section A.

Ordering Information:

P33LA 9 6 L G N N

| | | | | | | |
|--|---|------------------------------------|--|--|--|---------------------------------|
| Basic Series Global Modular Standard Lubricator P33LA | Thread Type BSPP 1 BSPT 2 NPT 9 | Port Size 1/2 4 3/4 6 | Lube Type Oil Mist Standard Sight Dome L | Drain Type N No Drain Closed End | Bowl Type G Poly Bowl with Bowl Guard S Metal Bowl with Sight Gauge | Mounting N No Bracket |
|--|---|------------------------------------|--|--|--|---------------------------------|

Suggested Lubricant **F442 Oil**

Petroleum based oil of 100 to 200 SUS viscosity at 100°F (38°C) and an aniline point greater than 200°F (93°C)
(DO NOT USE OILS WITH ADDITIVES, COMPOUNDED OILS CONTAINING SOLVENTS, GRAPHITE, DETERGENTS, OR SYNTHETIC OILS.)

Most popular.

B
 Global Air Preparation
 Introduction
 Filters
 Coalescers
 Regulators
 Filter / Regulators
 Lubricators
 Combinations
 Accessories and Kits



Standard Lubricators

Material Specifications

| | |
|---------------------|-----------------|
| Body | Aluminum |
| Body cap | ABS |
| Plastic bowl | Polycarbonate |
| Metal bowl | Aluminum |
| Seals | Nitrile |
| Sight dome | Polycarbonate |
| Sight gauge | Nylon |
| Suggested lubricant | ISO / ASTM VG32 |
| Pick-up filter | Sintered bronze |

Repair and Service Kits

| | |
|---------------------------------------|-------------------|
| Plastic bowl / bowl guard no drain | P33KA00BGN |
| Metal bowl / w/o sight gauge no drain | P33KA00BMN |
| Metal bowl / sight gauge no drain | P33KA00BSN |
| Drip control assembly | P32KA00PG |
| Fill plug | P32KA00PL |
| L-bracket (fits to body) | P33KA00ML |
| T-bracket (fits to body connector) | P32KA00MB |
| T-bracket with body connector | P32KA00MT |
| Body connector | P32KA00CB |
| Oil (1 quart) | F442001 |
| Oil (1 gallon) | F442002 |
| Oil (12 quart case) | F442003 |
| Oil (4 gallon case) | F442005 |

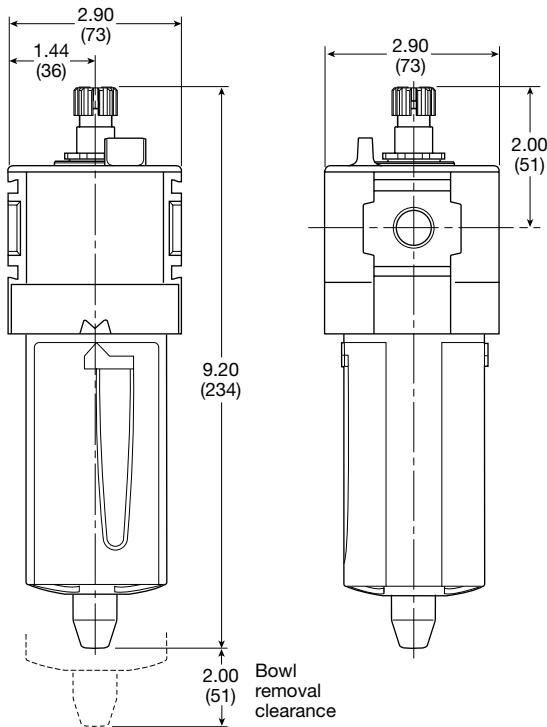

Air Preparation Products Global Air Preparation

Flow Charts

P33LA 1/2" Lubricator

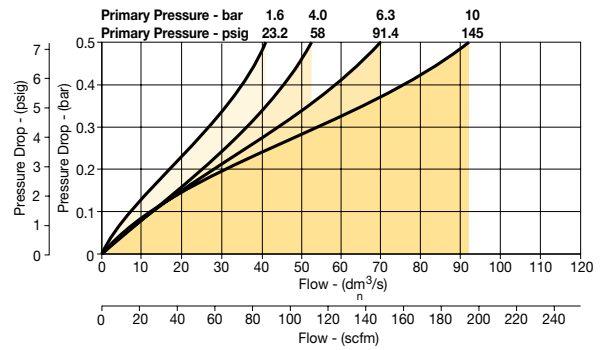

P33LA 3/4" Lubricator

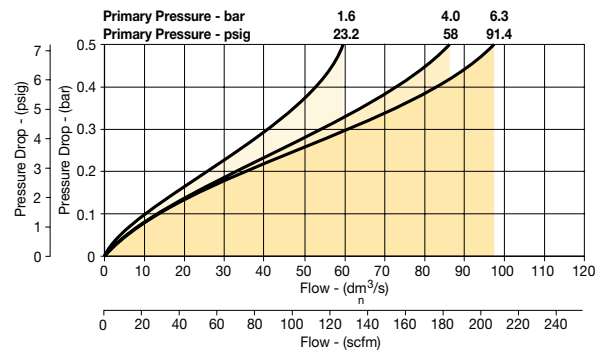

B

Global Air
Preparation

Introduction

Filters

Coalescers

Regulators

Filter /
Regulators

Lubricators

Combinations

Accessories
and Kits



Air Preparation Products Global Air Preparation

Mini Combinations

Popular Combinations: Inlet pressure 145 psig (10 bar), secondary pressure 100 psig (6.9 bar), 14.5 psig (1 bar) pressure drop.

B Global Air Preparation Introduction Filters Coalescers Regulators Filter / Regulators Lubricators Combinations Accessories and Kits



Filter + Regulator + Lubricator Combinations, poly bowl
5 micron element, 116 psig (8 bar) regulator + gauge and wall mounting brackets

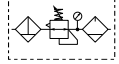

| Port Size | Flow | Manual Drain | Pulse Drain |
|-----------|--------------------------------------|------------------------|------------------------|
| 1/4" | 27 scfm (13 dm ³ /s, ANR) | P31CB92GEMN5LNW | P31CB92GEBN5LNW |



Filter/Regulator + Lubricator Combinations, poly bowl
5 micron element, 116 psig (8 bar) regulator + gauge and wall mounting brackets

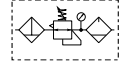

| Port Size | Flow | Manual Drain | Pulse Drain |
|-----------|--------------------------------------|------------------------|------------------------|
| 1/4" | 28 scfm (14 dm ³ /s, ANR) | P31CA92GEMN5LNW | P31CA92GEBN5LNW |



Ball Valve + Filter + Regulator + Lubricator Combinations, poly bowl
5 micron element, 116 psig (8 bar) regulator + gauge and wall mounting brackets

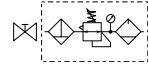

| Port Size | Flow | Manual Drain | Pulse Drain |
|-----------|--------------------------------------|------------------------|------------------------|
| 1/4" | 27 scfm (13 dm ³ /s, ANR) | P31QB92GEMN5LNW | P31QB92GEBN5LNW |



Ball Valve + Filter/Regulator + Lubricator Combinations, poly bowl
5 micron element, 116 psig (8 bar) regulator + gauge and wall mounting brackets

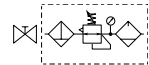

| Port Size | Flow | Manual Drain | Pulse Drain |
|-----------|--------------------------------------|------------------------|------------------------|
| 1/4" | 28 scfm (14 dm ³ /s, ANR) | P31QA92GEMN5LNW | P31QA92GEBN5LNW |

Filter / Regulator coding
(use with codes: A M)

| Filter coding (use with combo codes: B F G). For multiple filters, repeat as needed. | Regulator coding (use with combo code: B) | Lubricator coding (use with combo codes: A B) | Assembly configuration | | | | | | | | | | | | | | | | | | | | | | | | | | | | | | | | | | | | | | | | | | | | | | | | | | | | | | | | | |
|--|--|--|----------------------------|----------------------|-------------|---------------|---------------|--------------|-----------|--------------|-------------------|----------------|----------------|---------------|------------------|-----------------|-----------|--------------------------------------|---|--|---------|---------------------|------------------------|---------------------|-------------------|------------|-----------------------|----------------------|--|---------------------|--------------------------|------------------|--|-------------------|--|-------|-------------------|------------------|-------------------|-------------------|------|-----------------|----------------|----------------|-----------------|------|-------------------|------------------|------------------|------------------|---|----------|---------------------------------------|------------|-------------------------------|----------|---------------------|-----------------------|-----------------------------------|-----------------------|
| <p>P31 C B 9 2 G</p> <table border="1"> <tr><th>Combination</th><td>B/V + Combination Q</td></tr> <tr><td>Combination + B/V X</td></tr> <tr><td>Combination C</td></tr> </table> <p>B/V = Ball valve</p> <table border="1"> <tr><th>Thread Type</th><td>BSPP 1</td></tr> <tr><td>BSPT 2</td></tr> <tr><td>NPT 9</td></tr> </table> <table border="1"> <tr><th>Port Size</th><td>1/4 2</td></tr> </table> <table border="1"> <tr><th>Combination Type*</th><td>F/R+L A</td></tr> <tr><td>F+R+L B</td></tr> <tr><td>F+Fc F</td></tr> <tr><td>F+Fc+Fa G</td></tr> <tr><td>F/R+Fc M</td></tr> </table> <p>* Combination type F = 5μ Fc1 = 1μ Fc = .01μ Fa = Adsorber</p> <table border="1"> <tr><th>Bowl Type</th><td>Poly Bowl with Bowl Guard † G</td></tr> <tr><td>Metal Bowl without Sight Gauge M</td></tr> </table> <p>Note: All bowl types are the same for each component Example: If a "G" is specified for a F+L, both units would get a poly bowl with bowl guard. † For polycarbonate bowl, see caution in Engineering Section A.</p> | Combination | B/V + Combination Q | Combination + B/V X | Combination C | Thread Type | BSPP 1 | BSPT 2 | NPT 9 | Port Size | 1/4 2 | Combination Type* | F/R+L A | F+R+L B | F+Fc F | F+Fc+Fa G | F/R+Fc M | Bowl Type | Poly Bowl with Bowl Guard † G | Metal Bowl without Sight Gauge M | <p>E M</p> <table border="1"> <tr><th>Element</th><td>5μ Element E</td></tr> <tr><td>0.01μ Element C</td></tr> <tr><td>1μ Element 9</td></tr> <tr><td>Adsorber A</td></tr> </table> <table border="1"> <tr><th>Drain Type</th><td>Manual Drain M</td></tr> <tr><td>Pulse Drain B</td></tr> </table> | Element | 5μ Element E | 0.01μ Element C | 1μ Element 9 | Adsorber A | Drain Type | Manual Drain M | Pulse Drain B | <p>N 5</p> <table border="1"> <tr><th>Relief / Adjustment</th><td>Non-Rising Knob N</td></tr> </table> <table border="1"> <tr><th>Adjustment Range</th><td></td></tr> <tr><th>With Square Gauge</th><td></td></tr> <tr><th>Psig:</th><td>30 psig* 1</td></tr> <tr><td>60 psig 3</td></tr> <tr><td>125 psig 5</td></tr> <tr><td>232 psig 7</td></tr> <tr><th>Bar:</th><td>2 Bar* V</td></tr> <tr><td>4 Bar S</td></tr> <tr><td>8 Bar T</td></tr> <tr><td>16 Bar W</td></tr> </table> <table border="1"> <tr><th>MPa:</th><td>0.2 MPa* 2</td></tr> <tr><td>0.4 MPa 4</td></tr> <tr><td>0.8 MPa 6</td></tr> <tr><td>0.8 MPa 8</td></tr> </table> <p>* Regulator comes with gauge respective to the adjustment range available. ‡ Not available with poly bowl with bowl guard.</p> <p>Gauge supplied with every part. Gauge can be installed on the front or back of the regulator. If no gauge is installed, both seal screws must be installed.</p> | Relief / Adjustment | Non-Rising Knob N | Adjustment Range | | With Square Gauge | | Psig: | 30 psig* 1 | 60 psig 3 | 125 psig 5 | 232 psig 7 | Bar: | 2 Bar* V | 4 Bar S | 8 Bar T | 16 Bar W | MPa: | 0.2 MPa* 2 | 0.4 MPa 4 | 0.8 MPa 6 | 0.8 MPa 8 | <p>L N W</p> <table border="1"> <tr><th>Lub Type</th><td>Oil Mist Standard Sight Dome L</td></tr> </table> <table border="1"> <tr><th>Drain Type</th><td>No Drain; Closed End N</td></tr> </table> <table border="1"> <tr><th>Mounting</th><td>No Bracket A</td></tr> <tr><td>Port Blocks* C</td></tr> <tr><td>Port Blocks & Wall Brkt* D</td></tr> <tr><td>Wall Bracket W</td></tr> </table> <p>* For 3/8" Port Blocks please order separately. See Kits section.</p> | Lub Type | Oil Mist Standard Sight Dome L | Drain Type | No Drain; Closed End N | Mounting | No Bracket A | Port Blocks* C | Port Blocks & Wall Brkt* D | Wall Bracket W |
| Combination | B/V + Combination Q | | | | | | | | | | | | | | | | | | | | | | | | | | | | | | | | | | | | | | | | | | | | | | | | | | | | | | | | | | | |
| Combination + B/V X | | | | | | | | | | | | | | | | | | | | | | | | | | | | | | | | | | | | | | | | | | | | | | | | | | | | | | | | | | | | |
| Combination C | | | | | | | | | | | | | | | | | | | | | | | | | | | | | | | | | | | | | | | | | | | | | | | | | | | | | | | | | | | | |
| Thread Type | BSPP 1 | | | | | | | | | | | | | | | | | | | | | | | | | | | | | | | | | | | | | | | | | | | | | | | | | | | | | | | | | | | |
| BSPT 2 | | | | | | | | | | | | | | | | | | | | | | | | | | | | | | | | | | | | | | | | | | | | | | | | | | | | | | | | | | | | |
| NPT 9 | | | | | | | | | | | | | | | | | | | | | | | | | | | | | | | | | | | | | | | | | | | | | | | | | | | | | | | | | | | | |
| Port Size | 1/4 2 | | | | | | | | | | | | | | | | | | | | | | | | | | | | | | | | | | | | | | | | | | | | | | | | | | | | | | | | | | | |
| Combination Type* | F/R+L A | | | | | | | | | | | | | | | | | | | | | | | | | | | | | | | | | | | | | | | | | | | | | | | | | | | | | | | | | | | |
| F+R+L B | | | | | | | | | | | | | | | | | | | | | | | | | | | | | | | | | | | | | | | | | | | | | | | | | | | | | | | | | | | | |
| F+Fc F | | | | | | | | | | | | | | | | | | | | | | | | | | | | | | | | | | | | | | | | | | | | | | | | | | | | | | | | | | | | |
| F+Fc+Fa G | | | | | | | | | | | | | | | | | | | | | | | | | | | | | | | | | | | | | | | | | | | | | | | | | | | | | | | | | | | | |
| F/R+Fc M | | | | | | | | | | | | | | | | | | | | | | | | | | | | | | | | | | | | | | | | | | | | | | | | | | | | | | | | | | | | |
| Bowl Type | Poly Bowl with Bowl Guard † G | | | | | | | | | | | | | | | | | | | | | | | | | | | | | | | | | | | | | | | | | | | | | | | | | | | | | | | | | | | |
| Metal Bowl without Sight Gauge M | | | | | | | | | | | | | | | | | | | | | | | | | | | | | | | | | | | | | | | | | | | | | | | | | | | | | | | | | | | | |
| Element | 5μ Element E | | | | | | | | | | | | | | | | | | | | | | | | | | | | | | | | | | | | | | | | | | | | | | | | | | | | | | | | | | | |
| 0.01μ Element C | | | | | | | | | | | | | | | | | | | | | | | | | | | | | | | | | | | | | | | | | | | | | | | | | | | | | | | | | | | | |
| 1μ Element 9 | | | | | | | | | | | | | | | | | | | | | | | | | | | | | | | | | | | | | | | | | | | | | | | | | | | | | | | | | | | | |
| Adsorber A | | | | | | | | | | | | | | | | | | | | | | | | | | | | | | | | | | | | | | | | | | | | | | | | | | | | | | | | | | | | |
| Drain Type | Manual Drain M | | | | | | | | | | | | | | | | | | | | | | | | | | | | | | | | | | | | | | | | | | | | | | | | | | | | | | | | | | | |
| Pulse Drain B | | | | | | | | | | | | | | | | | | | | | | | | | | | | | | | | | | | | | | | | | | | | | | | | | | | | | | | | | | | | |
| Relief / Adjustment | Non-Rising Knob N | | | | | | | | | | | | | | | | | | | | | | | | | | | | | | | | | | | | | | | | | | | | | | | | | | | | | | | | | | | |
| Adjustment Range | | | | | | | | | | | | | | | | | | | | | | | | | | | | | | | | | | | | | | | | | | | | | | | | | | | | | | | | | | | | |
| With Square Gauge | | | | | | | | | | | | | | | | | | | | | | | | | | | | | | | | | | | | | | | | | | | | | | | | | | | | | | | | | | | | |
| Psig: | 30 psig* 1 | | | | | | | | | | | | | | | | | | | | | | | | | | | | | | | | | | | | | | | | | | | | | | | | | | | | | | | | | | | |
| 60 psig 3 | | | | | | | | | | | | | | | | | | | | | | | | | | | | | | | | | | | | | | | | | | | | | | | | | | | | | | | | | | | | |
| 125 psig 5 | | | | | | | | | | | | | | | | | | | | | | | | | | | | | | | | | | | | | | | | | | | | | | | | | | | | | | | | | | | | |
| 232 psig 7 | | | | | | | | | | | | | | | | | | | | | | | | | | | | | | | | | | | | | | | | | | | | | | | | | | | | | | | | | | | | |
| Bar: | 2 Bar* V | | | | | | | | | | | | | | | | | | | | | | | | | | | | | | | | | | | | | | | | | | | | | | | | | | | | | | | | | | | |
| 4 Bar S | | | | | | | | | | | | | | | | | | | | | | | | | | | | | | | | | | | | | | | | | | | | | | | | | | | | | | | | | | | | |
| 8 Bar T | | | | | | | | | | | | | | | | | | | | | | | | | | | | | | | | | | | | | | | | | | | | | | | | | | | | | | | | | | | | |
| 16 Bar W | | | | | | | | | | | | | | | | | | | | | | | | | | | | | | | | | | | | | | | | | | | | | | | | | | | | | | | | | | | | |
| MPa: | 0.2 MPa* 2 | | | | | | | | | | | | | | | | | | | | | | | | | | | | | | | | | | | | | | | | | | | | | | | | | | | | | | | | | | | |
| 0.4 MPa 4 | | | | | | | | | | | | | | | | | | | | | | | | | | | | | | | | | | | | | | | | | | | | | | | | | | | | | | | | | | | | |
| 0.8 MPa 6 | | | | | | | | | | | | | | | | | | | | | | | | | | | | | | | | | | | | | | | | | | | | | | | | | | | | | | | | | | | | |
| 0.8 MPa 8 | | | | | | | | | | | | | | | | | | | | | | | | | | | | | | | | | | | | | | | | | | | | | | | | | | | | | | | | | | | | |
| Lub Type | Oil Mist Standard Sight Dome L | | | | | | | | | | | | | | | | | | | | | | | | | | | | | | | | | | | | | | | | | | | | | | | | | | | | | | | | | | | |
| Drain Type | No Drain; Closed End N | | | | | | | | | | | | | | | | | | | | | | | | | | | | | | | | | | | | | | | | | | | | | | | | | | | | | | | | | | | |
| Mounting | No Bracket A | | | | | | | | | | | | | | | | | | | | | | | | | | | | | | | | | | | | | | | | | | | | | | | | | | | | | | | | | | | |
| Port Blocks* C | | | | | | | | | | | | | | | | | | | | | | | | | | | | | | | | | | | | | | | | | | | | | | | | | | | | | | | | | | | | |
| Port Blocks & Wall Brkt* D | | | | | | | | | | | | | | | | | | | | | | | | | | | | | | | | | | | | | | | | | | | | | | | | | | | | | | | | | | | | |
| Wall Bracket W | | | | | | | | | | | | | | | | | | | | | | | | | | | | | | | | | | | | | | | | | | | | | | | | | | | | | | | | | | | | |

Compact Combinations

Air Preparation Products Global Air Preparation

Popular Combinations: Inlet pressure 145 psig (10 bar), secondary pressure 91.3 psig (6.3 bar), 14.5 psig (1 bar) pressure drop.



Filter + Regulator + Lubricator Combinations, poly bowl
5 micron element, 116 psig (8 bar) regulator + gauge and wall mounting brackets

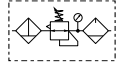

| Port Size | Flow | Manual Drain | Auto Drain |
|-----------|-------------------------|------------------------|------------------------|
| 1/4" | 42 scfm (20 dm³/s, ANR) | P32CB92GEMNGLNW | P32CB92GEANGLNW |
| 3/8" | 68 scfm (32 dm³/s, ANR) | P32CB93GEMNGLNW | P32CB93GEANGLNW |
| 1/2" | 85 scfm (40 dm³/s, ANR) | P32CB94GEMNGLNW | P32CB94GEANGLNW |



Filter/Regulator + Lubricator Combinations, poly bowl
5 micron element, 116 psig (8 bar) regulator + gauge and wall mounting brackets

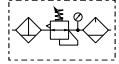

| Port Size | Flow | Manual Drain | Auto Drain |
|-----------|-------------------------|------------------------|------------------------|
| 1/4" | 45 scfm (22 dm³/s, ANR) | P32CA92GEMNGLNW | P32CA92GEANGLNW |
| 3/8" | 70 scfm (33 dm³/s, ANR) | P32CA93GEMNGLNW | P32CA93GEANGLNW |
| 1/2" | 90 scfm (43 dm³/s, ANR) | P32CA94GEMNGLNW | P32CA94GEANGLNW |



Ball Valve + Filter + Regulator + Lubricator Combinations, poly bowl
5 micron element, 116 psig (8 bar) regulator + gauge and wall mounting brackets

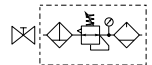

| Port Size | Flow | Manual Drain | Auto Drain |
|-----------|-------------------------|------------------------|------------------------|
| 1/4" | 42 scfm (20 dm³/s, ANR) | P32QB92GEMNGLNW | P32QB92GEANGLNW |
| 3/8" | 68 scfm (32 dm³/s, ANR) | P32QB93GEMNGLNW | P32QB93GEANGLNW |
| 1/2" | 85 scfm (40 dm³/s, ANR) | P32QB94GEMNGLNW | P32QB94GEANGLNW |



Ball Valve + Filter/Regulator + Lubricator Combinations, poly bowl
5 micron element, 116 psig (8 bar) regulator + gauge and wall mounting brackets

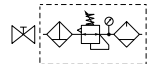

| Port Size | Flow | Manual Drain | Auto Drain |
|-----------|-------------------------|------------------------|------------------------|
| 1/4" | 45 scfm (22 dm³/s, ANR) | P32QA92GEMNGLNW | P32QA92GEANGLNW |
| 3/8" | 70 scfm (33 dm³/s, ANR) | P32QA93GEMNGLNW | P32QA93GEANGLNW |
| 1/2" | 90 scfm (43 dm³/s, ANR) | P32QA94GEMNGLNW | P32QA94GEANGLNW |

Filter / Regulator coding
(use with codes: A M)

| Filter coding (use with combo codes: B F G). For multiple filters, repeat as needed. | Regulator coding (use with combo code: B) | Lubricator coding (use with combo codes: A B) | Assembly configuration |
|---|--|---|---------------------------|
|---|--|---|---------------------------|

| | | | | | | | | | | | | | | | | | | | | | | | | | | | | | | | | | | | | | | | | | | | | | | | | | | | | | | | | | | | | | | | | | | | | | | | | | | | | | | | | | | | | | | |
|--|------------------|------------------|----------------|-----------------|---------------|--|-----------------------------|----------|--------------------------------|-----------|-----------------------------|----------|--|------|----------|------|----------|-----|----------|------|-----------|------|----------|------|----------|--|---------------|----------|------------------------|-----------|------------|----------|---------------------|-----------|------------|----------|---------------------|-----------|----------|----------|------------|----------|--------------|----------|---|-----------------|----------|-----------|----------|-------------------------|--|-------------------------|----------|-------------------------|----------|--------------------------|----------|---------------------------|------------|----------------------|--|-------------------------|----------|-------------------------|----------|--------------------------|----------|---------------------------|------------|---|-------------------|----------|------------|----------|----------------------|----------|--|------------|----------|-------------|----------|-------------------------|----------|--------------|----------|-----------------|
| <p>P32</p> <p>Combination</p> <p>B/V + Combination Q</p> <p>Combination + B/V X</p> <p>Combination C</p> <p>B/V = Ball valve</p> <p>Combination Type*</p> <table border="1"> <tr> <td>F/R+L A</td> <td>F+Fc+Fa G</td> </tr> <tr> <td>F+R+L B</td> <td>F/R+Fc M</td> </tr> <tr> <td>F+Fc F</td> <td></td> </tr> </table> <p>* Combination type F = 5µ Fc1 = 1µ Fc = .01µ Fa = Adsorber</p> <p>Bowl Type</p> <table border="1"> <tr> <td>Poly Bowl with Bowl Guard ‡</td> <td>G</td> </tr> <tr> <td>Metal Bowl without Sight Gauge</td> <td>M*</td> </tr> <tr> <td>Metal Bowl with Sight Gauge</td> <td>S</td> </tr> </table> <p>* Not available when using lubricator. Note: All bowl types are the same for each component. Example: If a "G" is specified for a F+L, both units would get a poly bowl with bowl guard.</p> | F/R+L A | F+Fc+Fa G | F+R+L B | F/R+Fc M | F+Fc F | | Poly Bowl with Bowl Guard ‡ | G | Metal Bowl without Sight Gauge | M* | Metal Bowl with Sight Gauge | S | <p>C</p> <p>Thread Type</p> <table border="1"> <tr> <td>BSPP</td> <td>1</td> </tr> <tr> <td>BSPT</td> <td>2</td> </tr> <tr> <td>NPT</td> <td>9</td> </tr> </table> <p>Port Size</p> <table border="1"> <tr> <td>1/4"</td> <td>2*</td> </tr> <tr> <td>3/8"</td> <td>3</td> </tr> <tr> <td>1/2"</td> <td>4</td> </tr> </table> <p>* Order combo Q or X: ball valve (BV) comes with 3/8 ports.</p> | BSPP | 1 | BSPT | 2 | NPT | 9 | 1/4" | 2* | 3/8" | 3 | 1/2" | 4 | <p>9 4 G</p> <p>Element</p> <table border="1"> <tr> <td>0.01µ Element</td> <td>C</td> </tr> <tr> <td>0.01µ Element with dpi</td> <td>D*</td> </tr> <tr> <td>5µ Element</td> <td>E</td> </tr> <tr> <td>5µ Element with dpi</td> <td>F*</td> </tr> <tr> <td>1µ Element</td> <td>9</td> </tr> <tr> <td>1µ Element with dpi</td> <td>Q*</td> </tr> <tr> <td>Adsorber</td> <td>A</td> </tr> </table> <p>* Not available with F/R.</p> <p>Drain Type</p> <table border="1"> <tr> <td>Auto Drain</td> <td>A</td> </tr> <tr> <td>Manual Drain</td> <td>M</td> </tr> </table> | 0.01µ Element | C | 0.01µ Element with dpi | D* | 5µ Element | E | 5µ Element with dpi | F* | 1µ Element | 9 | 1µ Element with dpi | Q* | Adsorber | A | Auto Drain | A | Manual Drain | M | <p>E M</p> <p>Relief / Adjustment</p> <table border="1"> <tr> <td>Non-Rising Knob</td> <td>N</td> </tr> <tr> <td>Relieving</td> <td>G</td> </tr> </table> <p>Adjustment Range</p> <table border="1"> <tr> <td>With Round Gauge</td> <td></td> </tr> <tr> <td>30 psig; 2 Bar; 0.2 MPa</td> <td>Z</td> </tr> <tr> <td>60 psig; 4 Bar; 0.4 MPa</td> <td>M</td> </tr> <tr> <td>125 psig; 8 Bar; 0.8 MPa</td> <td>G</td> </tr> <tr> <td>250 psig; 17 Bar; 1.7 MPa</td> <td>J§</td> </tr> <tr> <td>Without Gauge</td> <td></td> </tr> <tr> <td>30 psig; 2 Bar; 0.2 MPa</td> <td>Y</td> </tr> <tr> <td>60 psig; 4 Bar; 0.4 MPa</td> <td>L</td> </tr> <tr> <td>125 psig; 8 Bar; 0.8 MPa</td> <td>N</td> </tr> <tr> <td>250 psig; 17 Bar; 1.7 MPa</td> <td>H§</td> </tr> </table> | Non-Rising Knob | N | Relieving | G | With Round Gauge | | 30 psig; 2 Bar; 0.2 MPa | Z | 60 psig; 4 Bar; 0.4 MPa | M | 125 psig; 8 Bar; 0.8 MPa | G | 250 psig; 17 Bar; 1.7 MPa | J § | Without Gauge | | 30 psig; 2 Bar; 0.2 MPa | Y | 60 psig; 4 Bar; 0.4 MPa | L | 125 psig; 8 Bar; 0.8 MPa | N | 250 psig; 17 Bar; 1.7 MPa | H § | <p>N G</p> <p>Lub Type</p> <table border="1"> <tr> <td>Oil Mist Standard</td> <td>L</td> </tr> <tr> <td>Sight Dome</td> <td>N</td> </tr> </table> <p>Drain Type</p> <table border="1"> <tr> <td>No Drain; Closed End</td> <td>N</td> </tr> </table> | Oil Mist Standard | L | Sight Dome | N | No Drain; Closed End | N | <p>L N</p> <p>Mounting</p> <table border="1"> <tr> <td>No Bracket</td> <td>A</td> </tr> <tr> <td>Port Blocks</td> <td>C</td> </tr> <tr> <td>Port Blocks & Wall Brkt</td> <td>D</td> </tr> <tr> <td>Wall Bracket</td> <td>W</td> </tr> </table> | No Bracket | A | Port Blocks | C | Port Blocks & Wall Brkt | D | Wall Bracket | W | <p>W</p> |
| F/R+L A | F+Fc+Fa G | | | | | | | | | | | | | | | | | | | | | | | | | | | | | | | | | | | | | | | | | | | | | | | | | | | | | | | | | | | | | | | | | | | | | | | | | | | | | | | | | | | | | |
| F+R+L B | F/R+Fc M | | | | | | | | | | | | | | | | | | | | | | | | | | | | | | | | | | | | | | | | | | | | | | | | | | | | | | | | | | | | | | | | | | | | | | | | | | | | | | | | | | | | | |
| F+Fc F | | | | | | | | | | | | | | | | | | | | | | | | | | | | | | | | | | | | | | | | | | | | | | | | | | | | | | | | | | | | | | | | | | | | | | | | | | | | | | | | | | | | | | |
| Poly Bowl with Bowl Guard ‡ | G | | | | | | | | | | | | | | | | | | | | | | | | | | | | | | | | | | | | | | | | | | | | | | | | | | | | | | | | | | | | | | | | | | | | | | | | | | | | | | | | | | | | | |
| Metal Bowl without Sight Gauge | M* | | | | | | | | | | | | | | | | | | | | | | | | | | | | | | | | | | | | | | | | | | | | | | | | | | | | | | | | | | | | | | | | | | | | | | | | | | | | | | | | | | | | | |
| Metal Bowl with Sight Gauge | S | | | | | | | | | | | | | | | | | | | | | | | | | | | | | | | | | | | | | | | | | | | | | | | | | | | | | | | | | | | | | | | | | | | | | | | | | | | | | | | | | | | | | |
| BSPP | 1 | | | | | | | | | | | | | | | | | | | | | | | | | | | | | | | | | | | | | | | | | | | | | | | | | | | | | | | | | | | | | | | | | | | | | | | | | | | | | | | | | | | | | |
| BSPT | 2 | | | | | | | | | | | | | | | | | | | | | | | | | | | | | | | | | | | | | | | | | | | | | | | | | | | | | | | | | | | | | | | | | | | | | | | | | | | | | | | | | | | | | |
| NPT | 9 | | | | | | | | | | | | | | | | | | | | | | | | | | | | | | | | | | | | | | | | | | | | | | | | | | | | | | | | | | | | | | | | | | | | | | | | | | | | | | | | | | | | | |
| 1/4" | 2* | | | | | | | | | | | | | | | | | | | | | | | | | | | | | | | | | | | | | | | | | | | | | | | | | | | | | | | | | | | | | | | | | | | | | | | | | | | | | | | | | | | | | |
| 3/8" | 3 | | | | | | | | | | | | | | | | | | | | | | | | | | | | | | | | | | | | | | | | | | | | | | | | | | | | | | | | | | | | | | | | | | | | | | | | | | | | | | | | | | | | | |
| 1/2" | 4 | | | | | | | | | | | | | | | | | | | | | | | | | | | | | | | | | | | | | | | | | | | | | | | | | | | | | | | | | | | | | | | | | | | | | | | | | | | | | | | | | | | | | |
| 0.01µ Element | C | | | | | | | | | | | | | | | | | | | | | | | | | | | | | | | | | | | | | | | | | | | | | | | | | | | | | | | | | | | | | | | | | | | | | | | | | | | | | | | | | | | | | |
| 0.01µ Element with dpi | D* | | | | | | | | | | | | | | | | | | | | | | | | | | | | | | | | | | | | | | | | | | | | | | | | | | | | | | | | | | | | | | | | | | | | | | | | | | | | | | | | | | | | | |
| 5µ Element | E | | | | | | | | | | | | | | | | | | | | | | | | | | | | | | | | | | | | | | | | | | | | | | | | | | | | | | | | | | | | | | | | | | | | | | | | | | | | | | | | | | | | | |
| 5µ Element with dpi | F* | | | | | | | | | | | | | | | | | | | | | | | | | | | | | | | | | | | | | | | | | | | | | | | | | | | | | | | | | | | | | | | | | | | | | | | | | | | | | | | | | | | | | |
| 1µ Element | 9 | | | | | | | | | | | | | | | | | | | | | | | | | | | | | | | | | | | | | | | | | | | | | | | | | | | | | | | | | | | | | | | | | | | | | | | | | | | | | | | | | | | | | |
| 1µ Element with dpi | Q* | | | | | | | | | | | | | | | | | | | | | | | | | | | | | | | | | | | | | | | | | | | | | | | | | | | | | | | | | | | | | | | | | | | | | | | | | | | | | | | | | | | | | |
| Adsorber | A | | | | | | | | | | | | | | | | | | | | | | | | | | | | | | | | | | | | | | | | | | | | | | | | | | | | | | | | | | | | | | | | | | | | | | | | | | | | | | | | | | | | | |
| Auto Drain | A | | | | | | | | | | | | | | | | | | | | | | | | | | | | | | | | | | | | | | | | | | | | | | | | | | | | | | | | | | | | | | | | | | | | | | | | | | | | | | | | | | | | | |
| Manual Drain | M | | | | | | | | | | | | | | | | | | | | | | | | | | | | | | | | | | | | | | | | | | | | | | | | | | | | | | | | | | | | | | | | | | | | | | | | | | | | | | | | | | | | | |
| Non-Rising Knob | N | | | | | | | | | | | | | | | | | | | | | | | | | | | | | | | | | | | | | | | | | | | | | | | | | | | | | | | | | | | | | | | | | | | | | | | | | | | | | | | | | | | | | |
| Relieving | G | | | | | | | | | | | | | | | | | | | | | | | | | | | | | | | | | | | | | | | | | | | | | | | | | | | | | | | | | | | | | | | | | | | | | | | | | | | | | | | | | | | | | |
| With Round Gauge | | | | | | | | | | | | | | | | | | | | | | | | | | | | | | | | | | | | | | | | | | | | | | | | | | | | | | | | | | | | | | | | | | | | | | | | | | | | | | | | | | | | | | |
| 30 psig; 2 Bar; 0.2 MPa | Z | | | | | | | | | | | | | | | | | | | | | | | | | | | | | | | | | | | | | | | | | | | | | | | | | | | | | | | | | | | | | | | | | | | | | | | | | | | | | | | | | | | | | |
| 60 psig; 4 Bar; 0.4 MPa | M | | | | | | | | | | | | | | | | | | | | | | | | | | | | | | | | | | | | | | | | | | | | | | | | | | | | | | | | | | | | | | | | | | | | | | | | | | | | | | | | | | | | | |
| 125 psig; 8 Bar; 0.8 MPa | G | | | | | | | | | | | | | | | | | | | | | | | | | | | | | | | | | | | | | | | | | | | | | | | | | | | | | | | | | | | | | | | | | | | | | | | | | | | | | | | | | | | | | |
| 250 psig; 17 Bar; 1.7 MPa | J § | | | | | | | | | | | | | | | | | | | | | | | | | | | | | | | | | | | | | | | | | | | | | | | | | | | | | | | | | | | | | | | | | | | | | | | | | | | | | | | | | | | | | |
| Without Gauge | | | | | | | | | | | | | | | | | | | | | | | | | | | | | | | | | | | | | | | | | | | | | | | | | | | | | | | | | | | | | | | | | | | | | | | | | | | | | | | | | | | | | | |
| 30 psig; 2 Bar; 0.2 MPa | Y | | | | | | | | | | | | | | | | | | | | | | | | | | | | | | | | | | | | | | | | | | | | | | | | | | | | | | | | | | | | | | | | | | | | | | | | | | | | | | | | | | | | | |
| 60 psig; 4 Bar; 0.4 MPa | L | | | | | | | | | | | | | | | | | | | | | | | | | | | | | | | | | | | | | | | | | | | | | | | | | | | | | | | | | | | | | | | | | | | | | | | | | | | | | | | | | | | | | |
| 125 psig; 8 Bar; 0.8 MPa | N | | | | | | | | | | | | | | | | | | | | | | | | | | | | | | | | | | | | | | | | | | | | | | | | | | | | | | | | | | | | | | | | | | | | | | | | | | | | | | | | | | | | | |
| 250 psig; 17 Bar; 1.7 MPa | H § | | | | | | | | | | | | | | | | | | | | | | | | | | | | | | | | | | | | | | | | | | | | | | | | | | | | | | | | | | | | | | | | | | | | | | | | | | | | | | | | | | | | | |
| Oil Mist Standard | L | | | | | | | | | | | | | | | | | | | | | | | | | | | | | | | | | | | | | | | | | | | | | | | | | | | | | | | | | | | | | | | | | | | | | | | | | | | | | | | | | | | | | |
| Sight Dome | N | | | | | | | | | | | | | | | | | | | | | | | | | | | | | | | | | | | | | | | | | | | | | | | | | | | | | | | | | | | | | | | | | | | | | | | | | | | | | | | | | | | | | |
| No Drain; Closed End | N | | | | | | | | | | | | | | | | | | | | | | | | | | | | | | | | | | | | | | | | | | | | | | | | | | | | | | | | | | | | | | | | | | | | | | | | | | | | | | | | | | | | | |
| No Bracket | A | | | | | | | | | | | | | | | | | | | | | | | | | | | | | | | | | | | | | | | | | | | | | | | | | | | | | | | | | | | | | | | | | | | | | | | | | | | | | | | | | | | | | |
| Port Blocks | C | | | | | | | | | | | | | | | | | | | | | | | | | | | | | | | | | | | | | | | | | | | | | | | | | | | | | | | | | | | | | | | | | | | | | | | | | | | | | | | | | | | | | |
| Port Blocks & Wall Brkt | D | | | | | | | | | | | | | | | | | | | | | | | | | | | | | | | | | | | | | | | | | | | | | | | | | | | | | | | | | | | | | | | | | | | | | | | | | | | | | | | | | | | | | |
| Wall Bracket | W | | | | | | | | | | | | | | | | | | | | | | | | | | | | | | | | | | | | | | | | | | | | | | | | | | | | | | | | | | | | | | | | | | | | | | | | | | | | | | | | | | | | | |

* Regulator comes with gauge respective to the adjustment range selected.
§ Not available with poly bowl with bowl guard.

Air Preparation Products Global Air Preparation

Standard Combinations

Popular Combinations: Inlet pressure 145 psig (10 bar), secondary pressure 91.3 psig (6.3 bar), 14.5 psig (1 bar) pressure drop.

B
Global Air Preparation
Introduction
Filters
Coalescers
Regulators
Filter / Regulators
Lubricators
Combinations
Accessories and Kits



Filter + Regulator + Lubricator Combinations, poly bowl 5 micron element, 116 psig (8 bar) regulator + gauge and wall mounting brackets

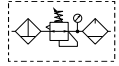

| Port Size | Flow | Manual Drain | Auto Drain |
|-----------|---------------------------------------|------------------------|------------------------|
| 1/2" | 90 scfm (43 dm ³ /s, ANR) | P33CB94GEMNGLNW | P33CB94GEANGLNW |
| 3/4" | 110 scfm (52 dm ³ /s, ANR) | P33CB96GEMNGLNW | P33CB96GEANGLNW |



Filter/Regulator + Lubricator Combinations, poly bowl 5 micron element, 116 psig (8 bar) regulator + gauge and wall mounting brackets

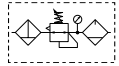

| Port Size | Flow | Manual Drain | Auto Drain |
|-----------|---------------------------------------|------------------------|------------------------|
| 1/2" | 110 scfm (52 dm ³ /s, ANR) | P33CA94GEMNGLNW | P33CA94GEANGLNW |
| 3/4" | 150 scfm (71 dm ³ /s, ANR) | P33CA96GEMNGLNW | P33CA96GEANGLNW |



Ball Valve + Filter + Regulator + Lubricator Combinations, poly bowl 5 micron element, 116 psig (8 bar) regulator + gauge and wall mounting brackets

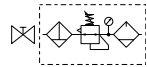

| Port Size | Flow | Manual Drain | Auto Drain |
|-----------|---------------------------------------|------------------------|------------------------|
| 1/2" | 90 scfm (43 dm ³ /s, ANR) | P33QB94GEMNGLNW | P33QB94GEANGLNW |
| 3/4" | 110 scfm (52 dm ³ /s, ANR) | P33QB96GEMNGLNW | P33QB96GEANGLNW |



Ball Valve + Filter/Regulator + Lubricator Combinations, poly bowl 5 micron element, 116 psig (8 bar) regulator + gauge and wall mounting brackets

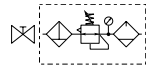

| Port Size | Flow | Manual Drain | Auto Drain |
|-----------|---------------------------------------|------------------------|------------------------|
| 1/2" | 110 scfm (52 dm ³ /s, ANR) | P33QA94GEMNGLNW | P33QA94GEANGLNW |
| 3/4" | 150 scfm (71 dm ³ /s, ANR) | P33QA96GEMNGLNW | P33QA96GEANGLNW |

Filter / Regulator coding (use with codes: A M)

Filter coding
(use with combo codes: B F G). For multiple filters, repeat as needed.

Regulator coding
(use with combo code: B)

Lubricator coding
(use with combo codes: A B)

Assembly configuration

| | | | | | | | | | | | | | | | | | | | | | | | | | | | | | | | | | | | | | | | | | | | | | | | | | | | | | | | | | | | | | | | | | | | | | | | | | | | | | | |
|--|-------------------|----------|-------------------|----------|-------------|----------|--|----------|----------|----------|----------|----------|--|---|----------|--------------------------------|-----------|-----------------------------|--|---|----------|------------------------|-----------|------------|----------|---------------------|-----------|------------|----------|---------------------|-----------|----------|----------|---|-----------------|----------|-----------|--|--|-------------------------|--|-------------------------|----------|-------------------------|----------|--------------------------|----------|---------------------------|-----------|----------------------|--|-------------------------|----------|-------------------------|----------|--------------------------|----------|---------------------------|-----------|--|----------|--|----------|----------|------------|--|--|----------------------|----------|--|------------|----------|-------------|----------|-------------------------|----------|--------------|----------|
| P33 | C | B | 9 | 6 | G | E | M | N | G | L | N | W | | | | | | | | | | | | | | | | | | | | | | | | | | | | | | | | | | | | | | | | | | | | | | | | | | | | | | | | | | | | | | | | | | |
| <p>Combination</p> <table border="1"> <tr><td>B/V + Combination</td><td>Q</td></tr> <tr><td>Combination + B/V</td><td>X</td></tr> <tr><td>Combination</td><td>C</td></tr> </table> <p>B/V = Ball valve</p> | B/V + Combination | Q | Combination + B/V | X | Combination | C | <p>Thread Type</p> <table border="1"> <tr><td>BSPP</td><td>1</td></tr> <tr><td>BSPT</td><td>2</td></tr> <tr><td>NPT</td><td>9</td></tr> </table> | BSPP | 1 | BSPT | 2 | NPT | 9 | <p>Port Size</p> <table border="1"> <tr><td>1/2</td><td>4</td></tr> <tr><td>3/4</td><td>6</td></tr> </table> | 1/2 | 4 | 3/4 | 6 | <p>Element</p> <table border="1"> <tr><td>0.01µ Element</td><td>C</td></tr> <tr><td>0.01µ Element with dpi</td><td>D*</td></tr> <tr><td>5µ Element</td><td>E</td></tr> <tr><td>5µ Element with dpi</td><td>F*</td></tr> <tr><td>1µ Element</td><td>9</td></tr> <tr><td>1µ Element with dpi</td><td>Q*</td></tr> <tr><td>Adsorber</td><td>A</td></tr> </table> <p>* Not available with F/R.</p> | 0.01µ Element | C | 0.01µ Element with dpi | D* | 5µ Element | E | 5µ Element with dpi | F* | 1µ Element | 9 | 1µ Element with dpi | Q* | Adsorber | A | <p>Relief / Adjustment</p> <table border="1"> <tr><td>Non-Rising Knob</td><td>N</td></tr> <tr><td>Relieving</td><td></td></tr> </table> | Non-Rising Knob | N | Relieving | | <p>Adjustment Range</p> <table border="1"> <tr><td colspan="2">With Round Gauge</td></tr> <tr><td>30 psig; 2 bar; 0.2 MPa</td><td>Z</td></tr> <tr><td>60 psig; 4 bar; 0.4 MPa</td><td>M</td></tr> <tr><td>125 psig; 8 bar; 0.8 MPa</td><td>G</td></tr> <tr><td>250 psig; 17 bar; 1.7 MPa</td><td>J*</td></tr> <tr><td colspan="2">Without Gauge</td></tr> <tr><td>30 psig; 2 bar; 0.2 MPa</td><td>Y</td></tr> <tr><td>60 psig; 4 bar; 0.4 MPa</td><td>L</td></tr> <tr><td>125 psig; 8 bar; 0.8 MPa</td><td>N</td></tr> <tr><td>250 psig; 17 bar; 1.7 MPa</td><td>H*</td></tr> </table> <p>* Not available with poly bowl with bowl guard.</p> | With Round Gauge | | 30 psig; 2 bar; 0.2 MPa | Z | 60 psig; 4 bar; 0.4 MPa | M | 125 psig; 8 bar; 0.8 MPa | G | 250 psig; 17 bar; 1.7 MPa | J* | Without Gauge | | 30 psig; 2 bar; 0.2 MPa | Y | 60 psig; 4 bar; 0.4 MPa | L | 125 psig; 8 bar; 0.8 MPa | N | 250 psig; 17 bar; 1.7 MPa | H* | <p>Lub Type</p> <table border="1"> <tr><td>Oil Mist</td><td></td></tr> <tr><td>Standard</td><td>L</td></tr> <tr><td>Sight Dome</td><td></td></tr> </table> | Oil Mist | | Standard | L | Sight Dome | | <p>Drain Type</p> <table border="1"> <tr><td>No Drain; Closed End</td><td>N</td></tr> </table> | No Drain; Closed End | N | <p>Mounting</p> <table border="1"> <tr><td>No Bracket</td><td>A</td></tr> <tr><td>Port Blocks</td><td>C</td></tr> <tr><td>Port Blocks & Wall Brkt</td><td>D</td></tr> <tr><td>Wall Bracket</td><td>W</td></tr> </table> | No Bracket | A | Port Blocks | C | Port Blocks & Wall Brkt | D | Wall Bracket | W |
| B/V + Combination | Q | | | | | | | | | | | | | | | | | | | | | | | | | | | | | | | | | | | | | | | | | | | | | | | | | | | | | | | | | | | | | | | | | | | | | | | | | | | | | |
| Combination + B/V | X | | | | | | | | | | | | | | | | | | | | | | | | | | | | | | | | | | | | | | | | | | | | | | | | | | | | | | | | | | | | | | | | | | | | | | | | | | | | | |
| Combination | C | | | | | | | | | | | | | | | | | | | | | | | | | | | | | | | | | | | | | | | | | | | | | | | | | | | | | | | | | | | | | | | | | | | | | | | | | | | | | |
| BSPP | 1 | | | | | | | | | | | | | | | | | | | | | | | | | | | | | | | | | | | | | | | | | | | | | | | | | | | | | | | | | | | | | | | | | | | | | | | | | | | | | |
| BSPT | 2 | | | | | | | | | | | | | | | | | | | | | | | | | | | | | | | | | | | | | | | | | | | | | | | | | | | | | | | | | | | | | | | | | | | | | | | | | | | | | |
| NPT | 9 | | | | | | | | | | | | | | | | | | | | | | | | | | | | | | | | | | | | | | | | | | | | | | | | | | | | | | | | | | | | | | | | | | | | | | | | | | | | | |
| 1/2 | 4 | | | | | | | | | | | | | | | | | | | | | | | | | | | | | | | | | | | | | | | | | | | | | | | | | | | | | | | | | | | | | | | | | | | | | | | | | | | | | |
| 3/4 | 6 | | | | | | | | | | | | | | | | | | | | | | | | | | | | | | | | | | | | | | | | | | | | | | | | | | | | | | | | | | | | | | | | | | | | | | | | | | | | | |
| 0.01µ Element | C | | | | | | | | | | | | | | | | | | | | | | | | | | | | | | | | | | | | | | | | | | | | | | | | | | | | | | | | | | | | | | | | | | | | | | | | | | | | | |
| 0.01µ Element with dpi | D* | | | | | | | | | | | | | | | | | | | | | | | | | | | | | | | | | | | | | | | | | | | | | | | | | | | | | | | | | | | | | | | | | | | | | | | | | | | | | |
| 5µ Element | E | | | | | | | | | | | | | | | | | | | | | | | | | | | | | | | | | | | | | | | | | | | | | | | | | | | | | | | | | | | | | | | | | | | | | | | | | | | | | |
| 5µ Element with dpi | F* | | | | | | | | | | | | | | | | | | | | | | | | | | | | | | | | | | | | | | | | | | | | | | | | | | | | | | | | | | | | | | | | | | | | | | | | | | | | | |
| 1µ Element | 9 | | | | | | | | | | | | | | | | | | | | | | | | | | | | | | | | | | | | | | | | | | | | | | | | | | | | | | | | | | | | | | | | | | | | | | | | | | | | | |
| 1µ Element with dpi | Q* | | | | | | | | | | | | | | | | | | | | | | | | | | | | | | | | | | | | | | | | | | | | | | | | | | | | | | | | | | | | | | | | | | | | | | | | | | | | | |
| Adsorber | A | | | | | | | | | | | | | | | | | | | | | | | | | | | | | | | | | | | | | | | | | | | | | | | | | | | | | | | | | | | | | | | | | | | | | | | | | | | | | |
| Non-Rising Knob | N | | | | | | | | | | | | | | | | | | | | | | | | | | | | | | | | | | | | | | | | | | | | | | | | | | | | | | | | | | | | | | | | | | | | | | | | | | | | | |
| Relieving | | | | | | | | | | | | | | | | | | | | | | | | | | | | | | | | | | | | | | | | | | | | | | | | | | | | | | | | | | | | | | | | | | | | | | | | | | | | | | |
| With Round Gauge | | | | | | | | | | | | | | | | | | | | | | | | | | | | | | | | | | | | | | | | | | | | | | | | | | | | | | | | | | | | | | | | | | | | | | | | | | | | | | |
| 30 psig; 2 bar; 0.2 MPa | Z | | | | | | | | | | | | | | | | | | | | | | | | | | | | | | | | | | | | | | | | | | | | | | | | | | | | | | | | | | | | | | | | | | | | | | | | | | | | | |
| 60 psig; 4 bar; 0.4 MPa | M | | | | | | | | | | | | | | | | | | | | | | | | | | | | | | | | | | | | | | | | | | | | | | | | | | | | | | | | | | | | | | | | | | | | | | | | | | | | | |
| 125 psig; 8 bar; 0.8 MPa | G | | | | | | | | | | | | | | | | | | | | | | | | | | | | | | | | | | | | | | | | | | | | | | | | | | | | | | | | | | | | | | | | | | | | | | | | | | | | | |
| 250 psig; 17 bar; 1.7 MPa | J* | | | | | | | | | | | | | | | | | | | | | | | | | | | | | | | | | | | | | | | | | | | | | | | | | | | | | | | | | | | | | | | | | | | | | | | | | | | | | |
| Without Gauge | | | | | | | | | | | | | | | | | | | | | | | | | | | | | | | | | | | | | | | | | | | | | | | | | | | | | | | | | | | | | | | | | | | | | | | | | | | | | | |
| 30 psig; 2 bar; 0.2 MPa | Y | | | | | | | | | | | | | | | | | | | | | | | | | | | | | | | | | | | | | | | | | | | | | | | | | | | | | | | | | | | | | | | | | | | | | | | | | | | | | |
| 60 psig; 4 bar; 0.4 MPa | L | | | | | | | | | | | | | | | | | | | | | | | | | | | | | | | | | | | | | | | | | | | | | | | | | | | | | | | | | | | | | | | | | | | | | | | | | | | | | |
| 125 psig; 8 bar; 0.8 MPa | N | | | | | | | | | | | | | | | | | | | | | | | | | | | | | | | | | | | | | | | | | | | | | | | | | | | | | | | | | | | | | | | | | | | | | | | | | | | | | |
| 250 psig; 17 bar; 1.7 MPa | H* | | | | | | | | | | | | | | | | | | | | | | | | | | | | | | | | | | | | | | | | | | | | | | | | | | | | | | | | | | | | | | | | | | | | | | | | | | | | | |
| Oil Mist | | | | | | | | | | | | | | | | | | | | | | | | | | | | | | | | | | | | | | | | | | | | | | | | | | | | | | | | | | | | | | | | | | | | | | | | | | | | | | |
| Standard | L | | | | | | | | | | | | | | | | | | | | | | | | | | | | | | | | | | | | | | | | | | | | | | | | | | | | | | | | | | | | | | | | | | | | | | | | | | | | | |
| Sight Dome | | | | | | | | | | | | | | | | | | | | | | | | | | | | | | | | | | | | | | | | | | | | | | | | | | | | | | | | | | | | | | | | | | | | | | | | | | | | | | |
| No Drain; Closed End | N | | | | | | | | | | | | | | | | | | | | | | | | | | | | | | | | | | | | | | | | | | | | | | | | | | | | | | | | | | | | | | | | | | | | | | | | | | | | | |
| No Bracket | A | | | | | | | | | | | | | | | | | | | | | | | | | | | | | | | | | | | | | | | | | | | | | | | | | | | | | | | | | | | | | | | | | | | | | | | | | | | | | |
| Port Blocks | C | | | | | | | | | | | | | | | | | | | | | | | | | | | | | | | | | | | | | | | | | | | | | | | | | | | | | | | | | | | | | | | | | | | | | | | | | | | | | |
| Port Blocks & Wall Brkt | D | | | | | | | | | | | | | | | | | | | | | | | | | | | | | | | | | | | | | | | | | | | | | | | | | | | | | | | | | | | | | | | | | | | | | | | | | | | | | |
| Wall Bracket | W | | | | | | | | | | | | | | | | | | | | | | | | | | | | | | | | | | | | | | | | | | | | | | | | | | | | | | | | | | | | | | | | | | | | | | | | | | | | | |
| <p>Combination Type*</p> <table border="1"> <tr><td>F/R+L</td><td>A</td><td>F+Fc+Fa</td><td>G</td></tr> <tr><td>F+R+L</td><td>B</td><td>F/R+Fc</td><td>M</td></tr> <tr><td>F+Fc</td><td>F</td><td></td><td></td></tr> </table> | F/R+L | A | F+Fc+Fa | G | F+R+L | B | F/R+Fc | M | F+Fc | F | | | <p>Bowl Type †</p> <table border="1"> <tr><td>Poly Bowl with Bowl Guard</td><td>G</td></tr> <tr><td>Metal Bowl without Sight Gauge</td><td>M*</td></tr> <tr><td>Metal Bowl with Sight Gauge</td><td>S</td></tr> </table> | Poly Bowl with Bowl Guard | G | Metal Bowl without Sight Gauge | M* | Metal Bowl with Sight Gauge | S | <p>* Combination type F = 5µ Fc = 1µ Fc = .01µ Fa = Adsorber</p> <p>† For polycarbonate bowl, see caution in Engineering Section A.</p> <p>* Not available when using lubricator. Note: All bowl types are the same for each component. Example: If a "G" is specified for a F+L, both units would get a poly bowl with bowl guard.</p> | | | | | | | | | | | | | | | | | | | | | | | | | | | | | | | | | | | | | | | | | | | | | | | | | | | | | | | | | | |
| F/R+L | A | F+Fc+Fa | G | | | | | | | | | | | | | | | | | | | | | | | | | | | | | | | | | | | | | | | | | | | | | | | | | | | | | | | | | | | | | | | | | | | | | | | | | | | |
| F+R+L | B | F/R+Fc | M | | | | | | | | | | | | | | | | | | | | | | | | | | | | | | | | | | | | | | | | | | | | | | | | | | | | | | | | | | | | | | | | | | | | | | | | | | | |
| F+Fc | F | | | | | | | | | | | | | | | | | | | | | | | | | | | | | | | | | | | | | | | | | | | | | | | | | | | | | | | | | | | | | | | | | | | | | | | | | | | | | |
| Poly Bowl with Bowl Guard | G | | | | | | | | | | | | | | | | | | | | | | | | | | | | | | | | | | | | | | | | | | | | | | | | | | | | | | | | | | | | | | | | | | | | | | | | | | | | | |
| Metal Bowl without Sight Gauge | M* | | | | | | | | | | | | | | | | | | | | | | | | | | | | | | | | | | | | | | | | | | | | | | | | | | | | | | | | | | | | | | | | | | | | | | | | | | | | | |
| Metal Bowl with Sight Gauge | S | | | | | | | | | | | | | | | | | | | | | | | | | | | | | | | | | | | | | | | | | | | | | | | | | | | | | | | | | | | | | | | | | | | | | | | | | | | | | |



Combination Dimensional Data

Air Preparation Products Global Air Preparation

Popular Combination Dimensions

inches (mm)

P31C

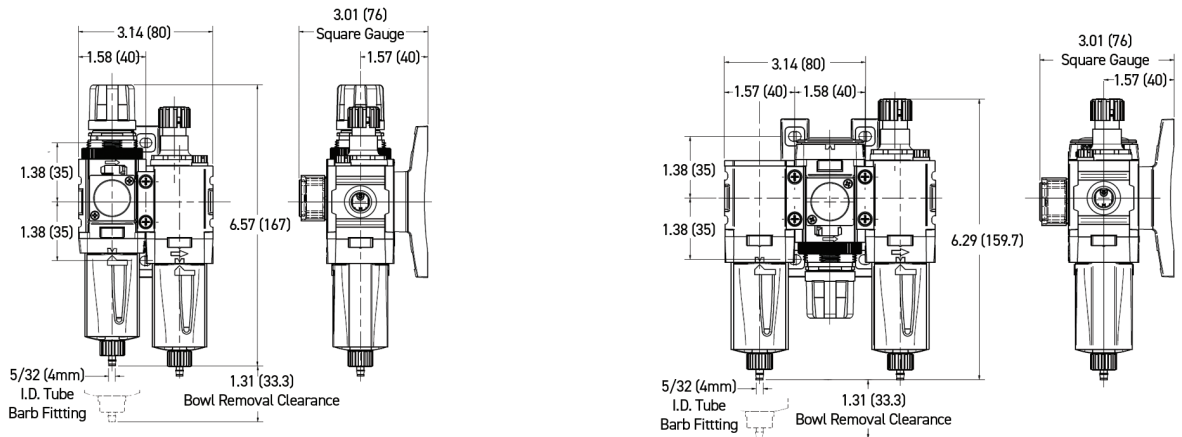

P32C

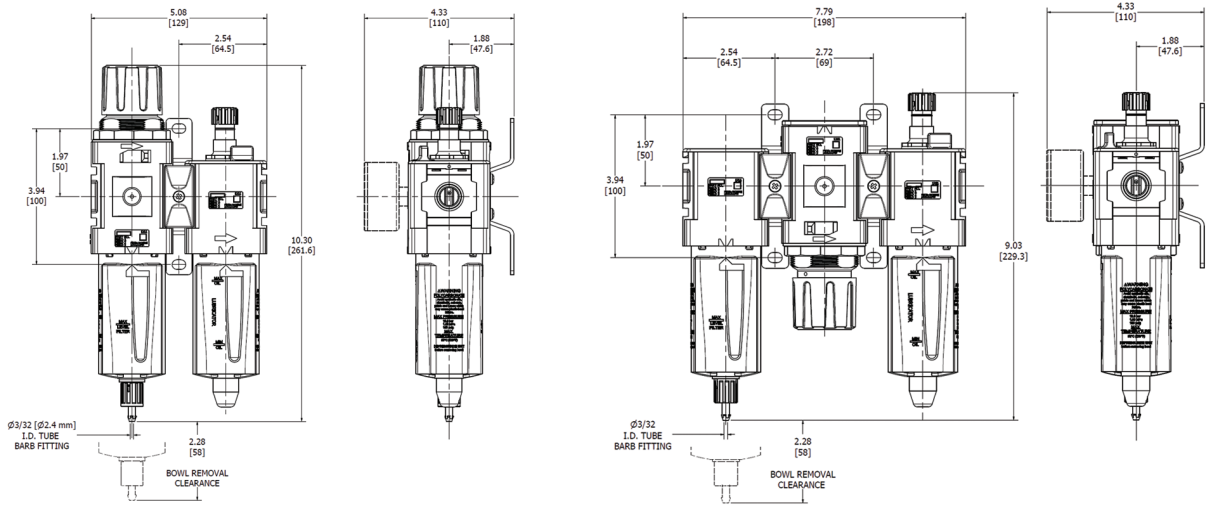

P33C

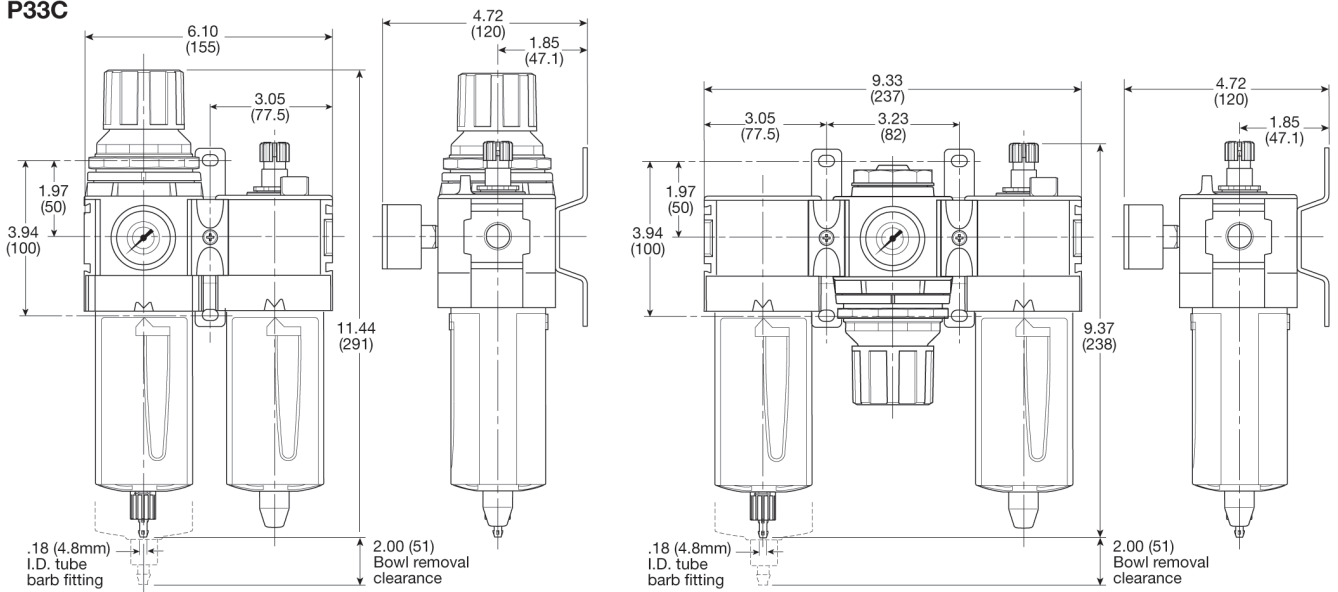

B

Global Air
Preparation

Introduction

Filters

Coalescers

Regulators

Filter /
Regulators

Lubricators

Combinations

Accessories
and Kits



Dump Valves

P31D & P32D Dump Valves

- Modular design with 1/4" or 1/2" integral ports (NPT & BSPP)
- The 3-way, 2-position function automatically dumps downstream pressure on the loss of pilot signal
- Solenoid or air pilot options
- High flow & exhaust capability
- Silencer included

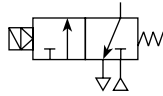

Remotely operated dump valves automatically shut off upstream pressure and exhaust the downstream pressure when the pilot pressure is released.

To maintain these units in the open position a pilot supply to the air pilot operated version or an electrical signal to the solenoid operated version must be maintained.

The valve will automatically dump when the holding signal is removed.

| Port Size | Description | Weight lbs (kg) | Part Number |
|-----------|---------------------------------------|-----------------|-----------------------|
| 1/4" | 120VAC Solenoid & cable plug | 0.8 (0.37) | P31DA92SGNC1FN |
| 1/4" | 24VDC Solenoid & cable plug † | 0.9 (0.41) | P31DA92SGNC2CN |
| 1/2" | 120VAC 30mm coil & cable plug incl. † | 1.5 (0.69) | P32DA94SCNA3GN |
| 1/2" | 24VDC 30mm coil & cable plug incl. † | 2.0 (0.91) | P32DA94SCNA2CN |
| 1/2" | External air pilot operated † | 1.9 (0.87) | P32DA94PPN |

† Includes exhaust silencer

Operating information

| | | |
|---------------------------|--------------------|---------------------------------------|
| Flow capacity*: | P31D | 36 scfm (17 dm ³ /s, ANR) |
| | P32D | 108 scfm (51 dm ³ /s, ANR) |
| Temperature range (max)†: | Solenoid operated | 14°F to 122°F (-10°C to 50°C) |
| | Air pilot operated | -4°F to 176°F (-20°C to 80°C) |
| Pressure (max): | Solenoid operated | 150 psig (10 bar) |
| | Air pilot operated | 250 psig (17 bar) |
| Operating pressure (min): | | 44 psig (3 bar) |
| Fluid: | | Compressed air |
| Ports: | Air pilot | 1/8 |
| | Exhaust | P31D - 1/4; P32D - 1/2 |
| | Gauge | P31D - 1/8; P32D - 1/4 |

* Inlet pressure 91.3 psig (6.3 bar), inlet pressure and 14.5 psig (1 bar) pressure drop.

† Air supply must be dry enough to avoid ice formation at temperatures below 35.6°F (2°C). Snap pressure: Full flow when downstream pressure reaches 50% of the inlet pressure.

Ordering Information:

P31DA 9 2 S G N C 2CN

Solenoid type only

| Body Size | Actuator Interface | Solenoid Voltage |
|--------------------------------|---------------------------------|---|
| Dump Valve (1/4") P31DA | G 15mm Solenoid (P31 Only) | 2CN 24VDC Non Locking Manual Override |
| Dump Valve (1/2") P32DA | C 30mm Solenoid | 3GN 120VAC Non Locking Manual Override |
| | P Threaded Air Pilot (P32 only) | 1FN 120VAC Non Locking Manual Override (P31 series only) |

| Thread Type | Pilot Type | Solenoid Type |
|-------------|---------------------------------|---|
| BSPP 1 | P External Air Pilot (P32 only) | C 15mm (P31 series only) |
| NPT 9 | S Solenoid Pilot | A 30mm CNOMO Coil (P32 only) |
| | | D 30mm CNOMO Coil (M12 connection) (P32 only) |

| Port Size |
|---------------------------------|
| Global Modular Mini (1/4") 2 |
| Global Modular Compact (1/2") 4 |

Note:
P32 unit used for both P32 & P33 series

☐ Most popular.

Global Air Preparation

Introduction

Filters

Coalescers

Regulators

Filter / Regulators

Lubricators

Combinations

Accessories and Kits



Dump Valves

Material Specifications

| | |
|------------|-------------|
| Body | Aluminum |
| Body cover | Polyester |
| Seals | Nitrile NBR |

Mounting Brackets

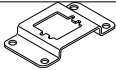
| | Description | Part Number |
|---|---------------------------|------------------|
|  | L-bracket mounting kit | P3HKA00ML |
|  | Foot bracket mounting kit | P3HKA00MC |

Note:

For solenoid operators and cable plugs (connectors) see pages B83 and B84.

Air Preparation Products Global Air Preparation

Flow Charts

P31DA 1/4" Remote Dump Valve

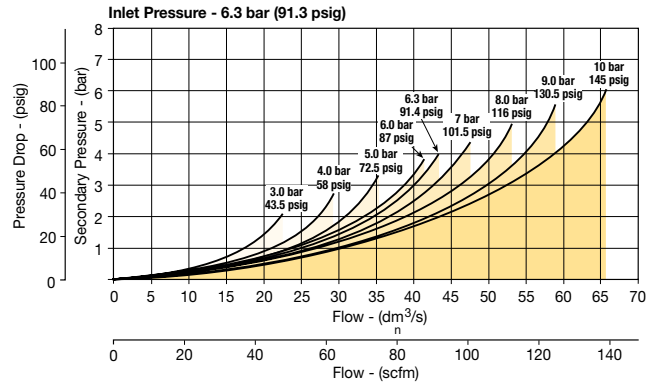

P32DA 1/2" Remote Dump Valve

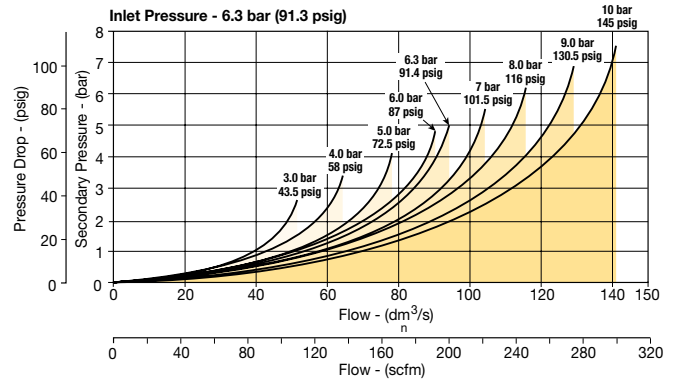

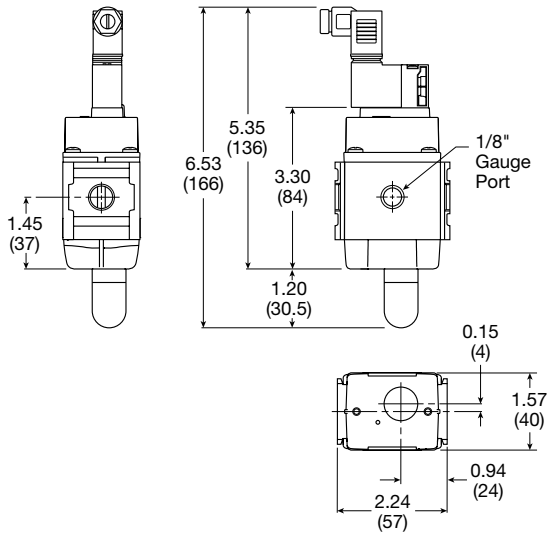

Dimensions inches (mm)

P31D

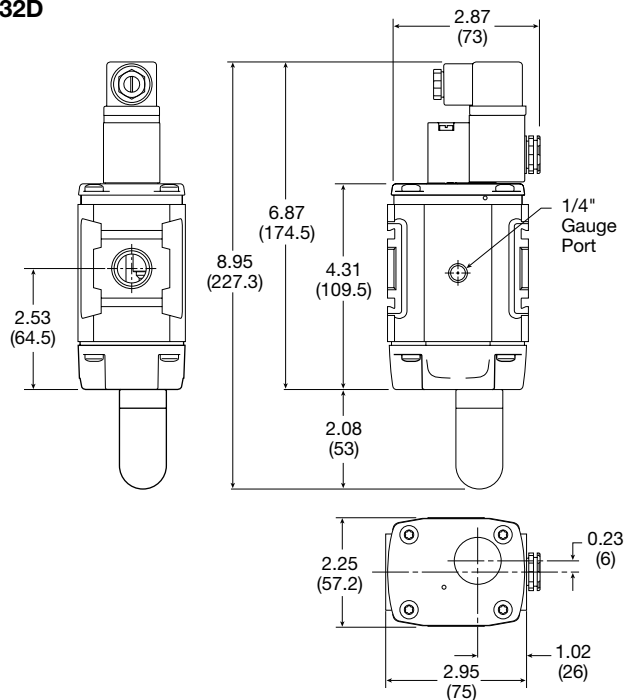

P32D



 Most popular.

Soft Start Valves

P31S & P32S Soft Start Valves

- Modular design with 1/4" or 1/2" integral ports (NPT & BSPT)
- The 2-way, 2-position function provides for the safe introduction of pressure
- Adjustable slow start
- Solenoid or air pilot options
- High flow

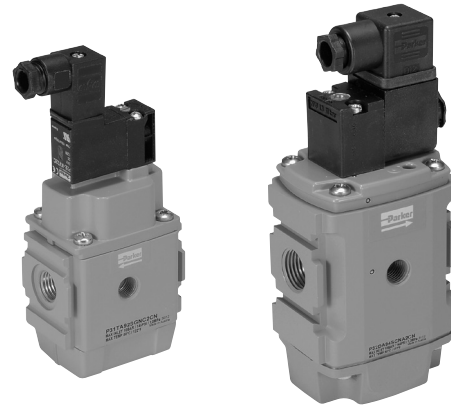
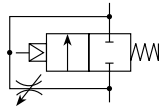

Parker Global Series Soft Start Valves, provide for the safe introduction of pressure to machines or systems. Soft Start Valves, allow the pressure to gradually build to the set point before fully opening to deliver full flow at line pressure.

The controlled introduction of pressure can be an important safety factor and prevent damage to tooling when air pressure is introduced at machine or system start up.

Note: Soft Start Valves must be installed downstream of a 3/2 valve with exhaust capability

| Port Size | Description | Weight lbs (kg) | Part Number |
|-----------|-------------------------------------|-----------------|-----------------------|
| 1/4" | 120VAC Solenoid & Cable Plug | 0.8 (0.37) | P31SA92SGNC1FN |
| 1/4" | 24VDC Solenoid & Cable Plug | 0.9 (0.41) | P31SA92SGNC2CN |
| 1/2" | 120VAC 30mm Coil & Cable Plug Incl. | 1.5 (0.87) | P32SA94SCNA3GN |
| 1/2" | 24VDC 30mm Coil & Cable Plug | 2.0 (0.90) | P32SA94SCNA2CN |
| 1/2" | Internal Air Pilot Operated | 2.0 (0.90) | P32SA94Y0N |
| 1/2" | External Air Pilot (1/8 threaded) | 1.5 (0.87) | P32SA94PPN |

Operating information

| | | |
|---------------------------|--------------------|---------------------------------------|
| Flow capacity*: | P31S | 36 scfm (17 dm ³ /s, ANR) |
| | P32S | 101 scfm (48 dm ³ /s, ANR) |
| Temperature range (max)†: | Solenoid operated | 14°F to 122°F (-10°C to 50°C) |
| | Air pilot operated | -4°F to 176°F (-20°C to 80°C) |
| Pressure (max): | Solenoid operated | 150 psig (10 bar) |
| | Air pilot operated | 250 psig (7 bar) |
| Operating pressure (min): | | 44 psig (3 bar) |
| Fluid: | | Compressed air |
| Ports: | Air pilot | 1/8 |
| | Gauge | P31S - 1/8; P32S - 1/4 |

* Inlet pressure 91.3 psig (6.3 bar), inlet pressure and 14.5 psig (1 bar) pressure drop.

† Air supply must be dry enough to avoid ice formation at temperatures below 35.6°F (2°C). Snap pressure: Full flow when downstream pressure reaches 50% of the inlet pressure.

Ordering Information:

P31SA

9

2

S

G

N

Solenoid type only

C

2CN

| Body Size | Actuator Interface | Solenoid Voltage | Solenoid type |
|-------------------------|--|---|--|
| Soft Start P31SA | 0 Internal Pilot (P32 only) | 2CN 24VDC non Locking Manual Override | C 15mm (P31 series only) |
| Soft Start P32SA | G 15mm Solenoid (P31 only) | 3GN 120VAC non Locking Manual Override | A 30mm CNOMO coil (P32 only) |
| | C 30mm Solenoid | 1FN 120VAC Non Locking Manual Override (P31 series only) | D 30mm CNOMO coil (M12 connection) (P32 only) |
| | P Threaded Air Pilot (P32 only) | | |

Thread Type

BSPP 1

NPT 9

Pilot type

P External air pilot (P32 only)

S Solenoid pilot

Y Internal air pilot (P32 only)

Port Size

Global Modular Mini (1/4") 2

Global Modular Compact (1/2") 4

Note: P32 unit used for both P32 & P33 series

☐ Most popular.



Soft Start Valves

Material Specifications

| | |
|------------|-------------|
| Body | Aluminum |
| Body cover | Polyester |
| Seals | Nitrile NBR |

Service Kits

| | | |
|------|---------------------------|------------------|
| P31S | L-bracket mounting kit | P3HKA00ML |
| | Foot bracket mounting kit | P3HKA00MC |
| P32S | L-bracket mounting kit | P3KKA00ML |
| | Foot bracket mounting kit | P3KKA00MC |

Note:

For solenoid operators and cable plugs (connectors) see pages B83 and B84.

Air Preparation Products Global Air Preparation

Flow Charts

P31SA 1/4" Soft Start Valve

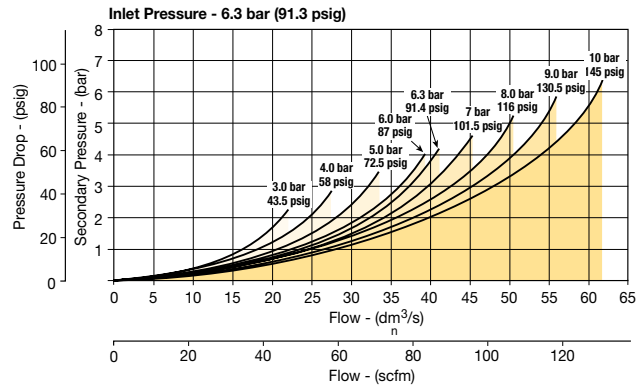

P32SA 1/2" Soft Start Valve

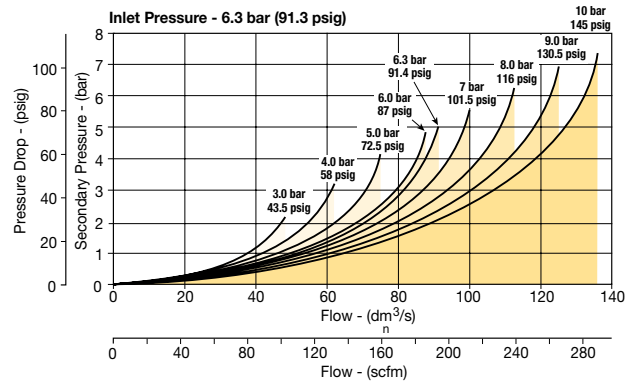

Dimensions inches (mm)

P31S

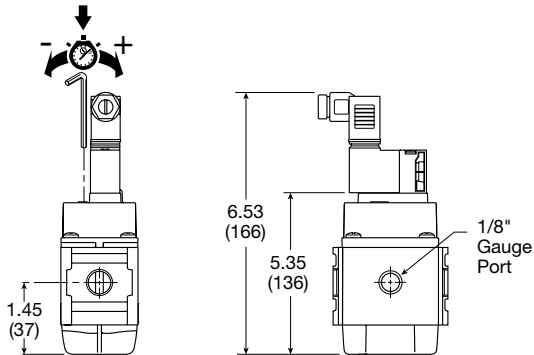

P32S

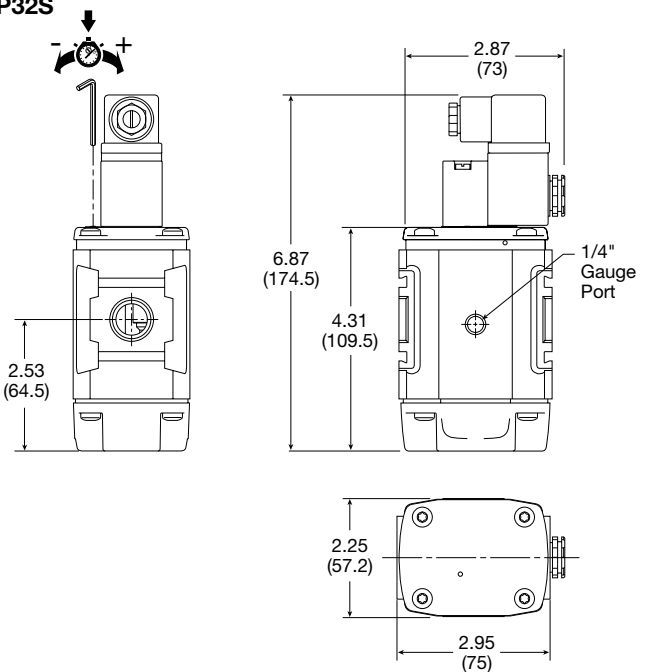

Soft Start Function:

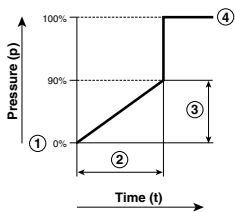

- ① Start signal
- ② Switching time delay
- ③ Gradual pressure build up
- ④ Operating pressure $p^2 (=p^1)$

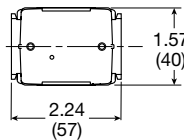

Combined Soft Start / Dump Valves

P31T & P32T Combined Soft Start / Dump Valves

- Modular design with 1/4" or 1/2" integral ports (NPT & BSPP)
- Provides for the safe introduction of pressure
- The 3-way, 2-position function automatically dumps downstream pressure on the loss of pilot signal
- Adjustable slow start
- Solenoid or air pilot options
- High flow & exhaust capability
- Silencer included

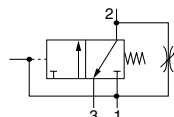

Parker Global Series Combined Soft Start / Dump Valves, provide for the safe introduction of pressure to machines or systems. Soft Start / Dump Valves when set, allow the pressure to gradually build to the set point before fully opening to deliver full flow at line pressure.

The controlled introduction of pressure can be an important safety factor and prevent damage to tooling when air pressure is introduced at machine or system start up.

To maintain these units in the open position a pilot supply to the air pilot operated version or an electrical signal to the solenoid operated version must be maintained. The valve will automatically dump when the holding signal is removed.

| Port Size | Description | Weight lbs (kg) | Part Number |
|-----------|-------------------------------------|-----------------|-----------------------|
| 1/4" | 120VAC Solenoid & cable plug | 0.8 (0.37) | P31TA92SGNC1FN |
| 1/4" | 24VDC Solenoid & cable plug | 0.9 (0.41) | P31TA92SGNC2CN |
| 1/2" | 120VAC 30mm coil & cable plug incl. | 1.9 (0.87) | P32TA94SCNA3GN |
| 1/2" | 24VDC 30mm coil & cable plug incl. | 2.0 (0.91) | P32TA94SCNA2CN |
| 1/2" | External air pilot operated | 1.9 (0.87) | P32TA94PPN |

Operating information

| | | |
|---------------------------|--------------------|---------------------------------------|
| Flow capacity*: | P31T | 36 scfm (17 dm ³ /s, ANR) |
| | P32T | 108 scfm (51 dm ³ /s, ANR) |
| Temperature range (max)†: | | |
| | Solenoid operated | 14°F to 122°F (-10°C to 50°C) |
| | Air pilot operated | -4°F to 176°F (-20°C to 80°C) |
| Pressure (max): | | |
| | Solenoid operated | 150 psig (10 bar) |
| | Air pilot operated | 250 psig (7 bar) |
| Operating pressure (min): | | 44 psig (3 bar) |
| Fluid: | | Compressed air |
| Ports: | Air pilot | 1/8 |
| | Exhaust | P31T - 1/4; P32T - 1/2 |
| | Gauge | P31T - 1/8; P32T - 1/4 |

* Inlet pressure 91.3 psig (6.3 bar), inlet pressure and 14.5 psig (1 bar) pressure drop.

† Air supply must be dry enough to avoid ice formation at temperatures below 35.6°F (2°C). Snap pressure: Full flow when downstream pressure reaches 50% of the inlet pressure.

Ordering Information:

P31TA 9 2 S G N C 2CN

| Body Size | Actuator Interface | Solenoid Voltage |
|--------------------------------------|---------------------------------|--|
| Soft Start / Dump Valve (1/4") P31TA | G 15mm Solenoid (P31 only) | 2CN 24VDC Non Locking Manual Override |
| Soft Start / Dump Valve (1/2") P32TA | C 30mm Solenoid | 3GN 120VAC Non Locking Manual Override |
| | P Threaded Air Pilot (P32 only) | 1FN 120VAC Non Locking Manual Override (P31 series only) |

| Thread Type | Pilot Type | Solenoid Type |
|-------------|---------------------------------|---|
| BSPP 1 | P External Air Pilot (P32 only) | C 15mm (P31 series only) |
| NPT 9 | S Solenoid Pilot | A 30mm CNOMO Coil (P32 only) |
| | | D 30mm CNOMO Coil (M12 connection) (P32 only) |

| Port Size |
|---------------------------------|
| Global Modular Mini (1/4") 2 |
| Global Modular Compact (1/2") 4 |

Note:
P32 unit used for both P32 & P33 series

Most popular.

Global Air Preparation

Introduction

Filters

Coalescers

Regulators

Filter / Regulators

Lubricators

Combinations

Accessories and Kits

Combined Soft Start / Dump Valves

Air Preparation Products Global Air Preparation

Material Specifications

| | |
|------------|-------------|
| Body | Aluminum |
| Body cover | Polyester |
| Seals | Nitrile NBR |

Service Kits

| | | |
|------|---------------------------|------------------|
| P31T | L-bracket mounting kit | P3HKA00ML |
| | Foot bracket mounting kit | P3HKA00MC |
| P32T | L-bracket mounting kit | P3KKA00ML |
| | Foot bracket mounting kit | P3KKA00MC |

Note:

For solenoid operators and cable plugs (connectors) see pages B83 and B84.

Flow Charts

P31TA 1/4" Soft Start & Dump Valve

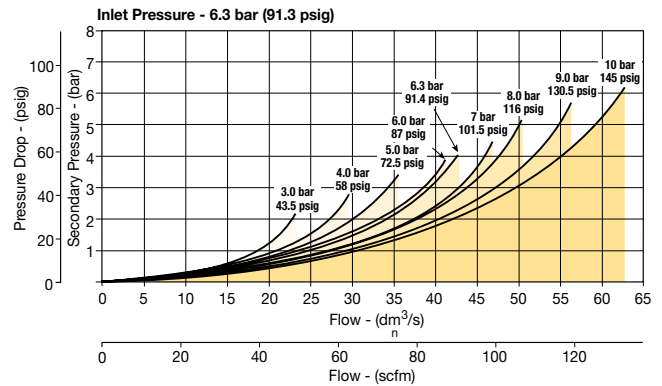

P32TA 1/2" Soft Start & Dump Valve

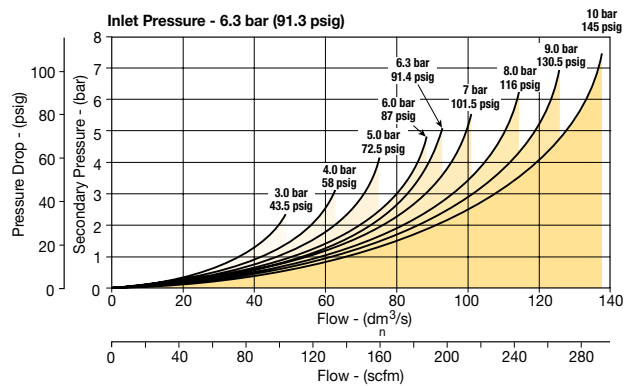

Dimensions inches (mm)

P31T

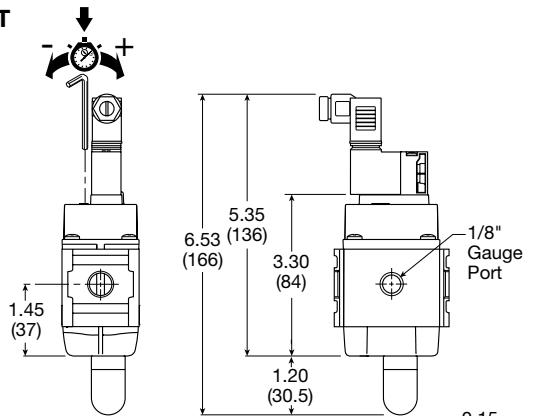

P32T

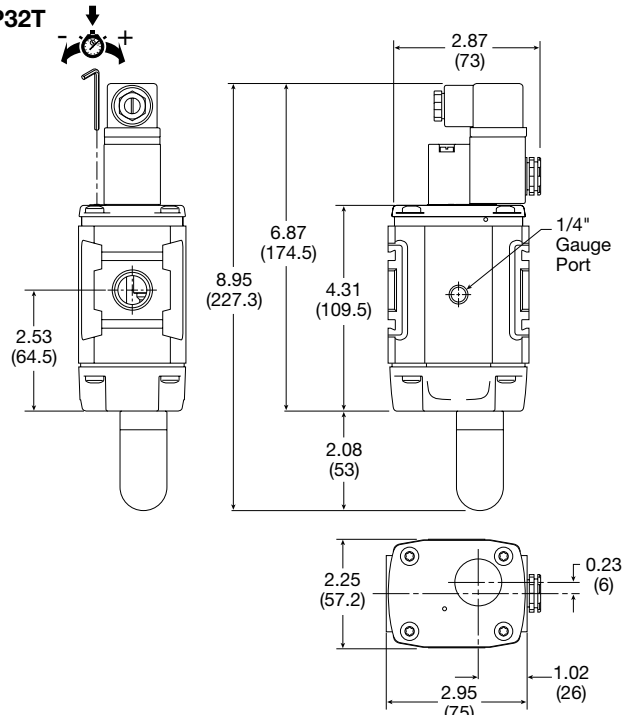

Soft Start Function:

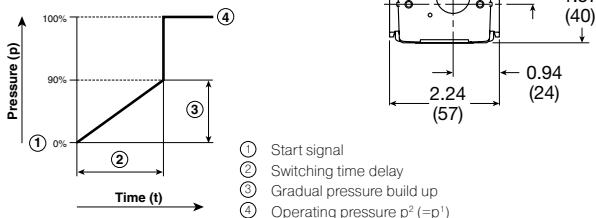

| | |
|----------------------|------------------------|
| B | Global Air Preparation |
| Introduction | Filters |
| Coalescers | Regulators |
| Regulators | Filter / Regulators |
| Lubricators | Combinations |
| Accessories and Kits | |

Safety Exhaust Valves

P33D & P33T Safety Exhaust Valves

- Easy electrical interface with M12 connectors to safety circuit
- External monitoring provides a cost and space saving advantage
- Solid state pressure sensors provide accurate, fast fault detection
- Quick visual LED indicators on the front of the valve
- Superior seated seal design for longer life
- Safety exhaust outlet is no-maintenance and non-clog by design
- Suitable for stand alone use or modular mounting to P32 or P33 FRL assembly
- High B10 life value
- Fast exhaust times allow for smaller machine footprint

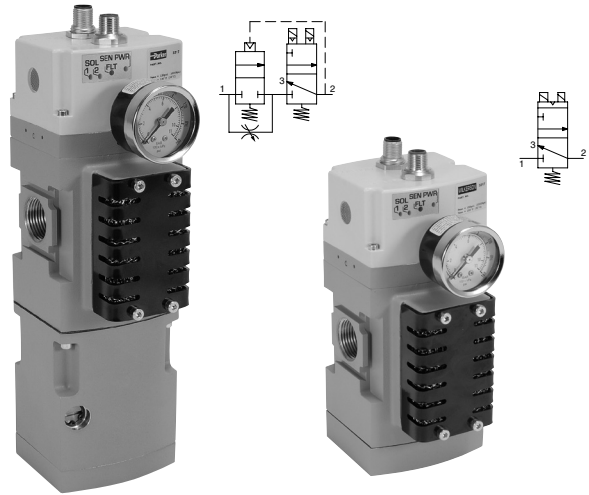

(optional soft start)



Operating information

| | |
|-----------------------------|---|
| Operating pressure: | 30 to 150 PSIG (2 to 10 bar) |
| Minimum operating pressure: | 30 PSIG (2 bar) |
| Ambient temperature: | 40° to 120°F (4° to 50°C) |
| Recommended filtration: | 40µ |
| Operating medium: | Compressed air |
| Ingress protection class: | IP65 |
| B10 (mio): | 12.5 million switching cycles |
| B10 d (mio): | 25 million switching cycles |
| Allowable discordance: | 150ms |
| Flow media: | Compresses air to ISO 8573-1 Class 7:4:4 |
| Weight lbs (kg): | 6.5 (2.9) with soft start 4.2 (1.9) without soft start |

The soft start opens to full flow at approximately 60% of input pressure.

Ordering Information:

| | | | | | | | | | | |
|---------------------------|--------------------------|---|---------------------------|-------------------------|---|---|-------------------------------------|--|-------------------------------------|----------------------------|
| P3 | 3 | T | B | 1 | 6 | A | B | E | N | F |
| | Global Standard 3 | Design Current B | | Port Size 3/4" 6 | | | Sensor Monitoring External E | | Gauge² No Gauge N | Options Black Grill |
| Series Standard P3 | | Type Safety Redundant (no soft start) D | Thread Type BSPP 1 | | Output for Solenoid, M12 Connector Pin 2 & 4, Common 3 A | Output for Sensors, M12 Connector Pin 1 & 2, 1 & 4, Common 3 A | | Dial Gauge³ G (standard) | Threaded Exhaust F | |
| | | Type Safety Redundant (c/w soft start) T | Thread Type NPT 9 | | 3 & 4 C | 1 & 2, 5 & 4, Common 3 B | | Digital Gauge³ D | | |
| | | | | | 2 & 4 D | 5 & 2, 1 & 4, Common 3 C | | MPS-P34 Pressure Sensor M | | |

Notes:

1. For 1/2" connections use 1/2" port blocks on standard 3/4" housing.
2. Safety valve supplied with 1/8" gauge port in either BSPP or NPT threads as specified for ports. Gauges shipped loose.
3. Dial or digital gauge not available on BSPP version.

Most popular.

Note: Mounting hardware and port blocks are sold separately.

B Global Air Preparation
 Introduction
 Filters
 Coalescers
 Regulators
 Filter / Regulators
 Lubricators
 Combinations
 Accessories and Kits



Safety Exhaust Valves

General Technical Data

| | |
|------------------|--|
| Valve type | Externally monitored, redundant, dual poppet |
| Soft start | Optional |
| Valve function | 3/2 way, normally closed |
| Housing material | Cast aluminum |
| Seals | NBR |
| Fasteners | Stainless steel / brass |
| Silencer | Steel, non clog safety design |

Electrical Specifications

| | |
|---|--------------------|
| Operating voltage | 24V DC |
| Electrical connection | Two M12 connectors |
| Switching time 1-2 (ms) | 23.3 |
| Switching time 2-3 (ms) | 42.7 |
| Duty cycle (%) | 100% |
| Operating voltage (DC) | 21.6 to 26.4 |
| Nominal power | |
| per solenoid coil at 24V DC (W) +/- 10% | 1.2 W |
| per pressure sensor at 24V DC | 1.2 W |

In accordance with EN ISO 13849-1 this safety valve is suitable for use up to Category 4, Pl e, sil 3. Certified to cCSAus and bears the CE mark.

A product Integration Guide is available to help connect your logic controller to the Parker Safety Exhaust Valve under the Product Support tab at www.parker.com/pdn/safetyvalve

Externally Monitored (with Soft Start)

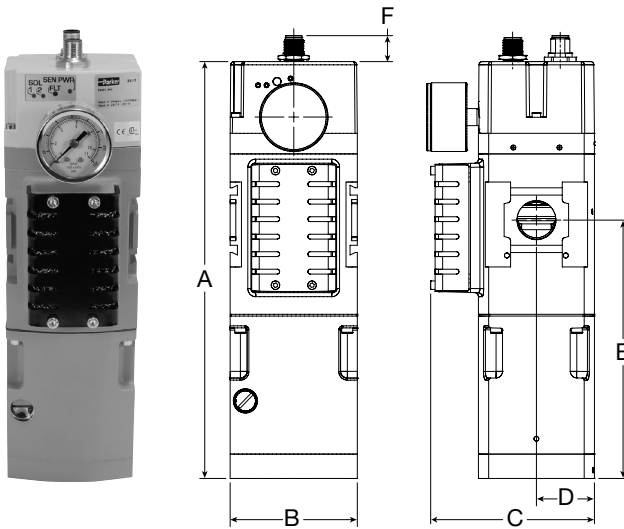

Air Preparation Products Global Air Preparation

Mounting Hardware

| | | |
|--|-----------|------------------|
| Body Connector | | P32KA00CB |
| T-Bracket w / Body Connector | | P32KA00MT |
| T-Bracket (fits to body connector or port block) | | P32KA00MB |
| Port Block Kits (includes two) | 1/2" NPT | P32KA94CP |
| | 1/2" BSPT | P32KA24CP |
| | 1/2" BSPP | P32KA14CP |
| | 3/4" NPT | P32KA96CP |
| | 3/4" BSPT | P32KA26CP |
| | 3/4" BSPP | P32KA16CP |

Solenoid M12 Pinouts

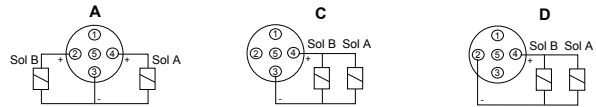

Pressure Sensor M12 Pinouts

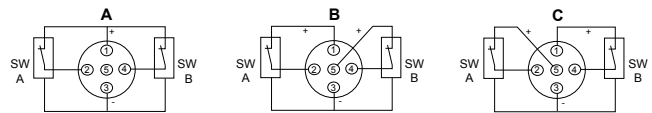

Externally Monitored (No Soft Start)

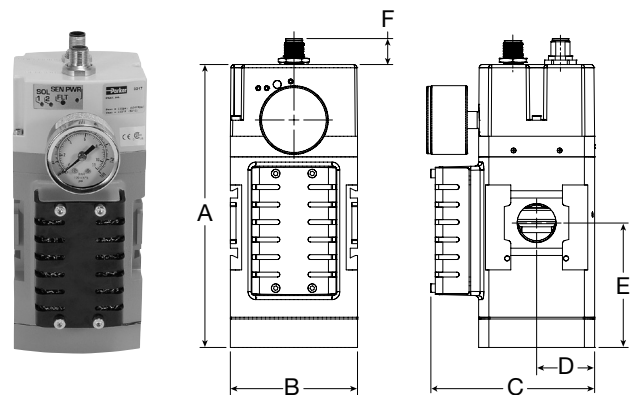

Dimensions inches (mm)

| | Ports | Standard nominal flow rate | | A | B | C | D | E | F |
|--------------------------------------|-------|----------------------------|---------------------|---------------|-----------|--------------|-------------|--------------|-------------|
| | | 1 → 2 L/min (SCFM)* | 2 → 3 L/min (SCFM)* | | | | | | |
| Externally Monitored with soft start | 3/4" | 4,100 (145) | 7,500 (265) | 10.31 (261.9) | 3.15 (80) | 4.30 (109.3) | 1.44 (36.5) | 6.39 (162.3) | 0.64 (16.3) |
| Externally Monitored no soft start | 3/4" | 4,300 (152) | 7,500 (265) | 7.03 (178.7) | 3.15 (80) | 4.30 (109.3) | 1.44 (36.5) | 3.11 (79.0) | 0.64 (16.3) |

* Standard nominal flow rate is based on 6 bar input pressure with ΔP = 1 bar



Safety Exhaust Valves

Safety Exhaust Valve Function

When applications demand a safe environment you can count on safety valves from Parker Hannifin. The P33 family of safety exhaust valves are 3/2 normally closed valves designed to rapidly exhaust compressed air in the event of a fault condition and to provide monitored coverage ensuring safe function. The P33 is available in two distinct styles, internally* or externally monitored. The valve is suitable for use up to Category 4, performance level e. Monitoring is achieved externally via a two channel system connected to a safety interface device. Both valves are available with an adjustable soft start and high flow exhaust to shut your equipment down faster when needed. LED's provide clear status of main solenoid operation, sensor power and fault condition for quick visual reference.

Externally Monitored Valve, Faults and Resets

The externally monitored valve has the monitoring done via a PLC or relay which offers a size and cost advantage over internally monitored valves. The integration of a safety interface into the PLC or relay will help determine the achievable category and performance level of the control system. Customers are required to provide the logic function via the safety device. The valve will lock-out to the "safe state" if asynchronous movement of the valve elements occur which will be detected by solid state pressure sensors. To achieve the proper safety rating, the safety PLC or relay must monitor the solid state pressure sensors to ensure they are not in different states for more than 50ms. If the sensors are in different states for longer than 50ms then the programming logic must shut off power to the solenoids and consider it a fault condition. If during operation the externally monitored P33 enters a fault condition the valve will shut off. A separate reset signal must be incorporated into the logic sequence to avoid automatic restart of the valve. The safety exhaust valves are not for use with clutch or brake applications and are designed for use in conjunction with a safety relay or safety PLC for safe monitoring and fault detection.

Achieving Desired Performance Level **

The category and performance level (PLr) needed for your machine is determined by a risk assessment of the machinery design and application based on EN ISO 13849-1. The Parker P33 safety valve is designed for those applications requiring a PL of d or e. Please note these levels require other aspects of the system to meet these requirements. As a guide: you can achieve a Cat 4 PL e system by integrating monitoring via a programmable safety rated device. Because the P33 is a mechanical fail-safe device, the monitoring could also be done via a standard PLC and still attain as high as a PL d rating.

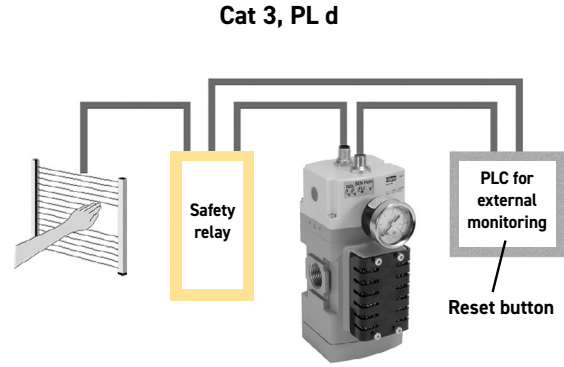

Cat 3, PL d

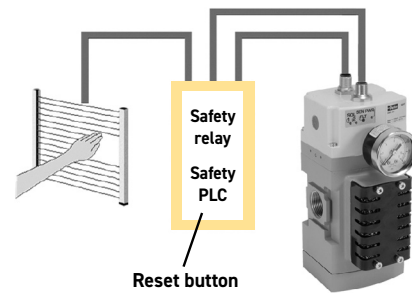

Cat 4, PL e

* For information on internally monitored safety valves reference Bulletin 0700-B14.
** An integration guide is available to provide further information on connecting the safety valve product to achieve the desired performance level. Please consult Parker and the standard EN ISO 13849-1 for more information.

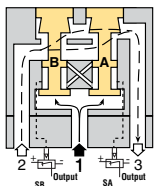

Conditions at Start

The Safety exhaust valve starts with inlet 1 closed to outlet 2 by both valve elements A and B. Outlet 2 is open to exhaust 3. Pressure signals at both sensors SA and SB are exhausted and contacts 1 and 2 of sensors SA and SB are connected. The normally closed sensors both provide voltage feedback signals to the external monitoring system.

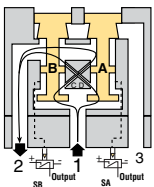

Normal Operation

During normal operation the two solenoids are simultaneously energized which actuates both pilots and causes valve elements A and B to shift. Inlet 1 is then connected to outlet 2 via crossflow passages C and D. Exhaust 3 is closed. Sensing pressure signals go to each pressure sensor and become equal to inlet pressure. Both sensors contacts open and no voltage signals are provided to the external monitoring system. This indicates that both sides of the valve actuated as expected.

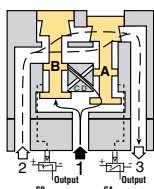

Detecting a Malfunction

A malfunction in the system or the valve itself could cause one valve element to be open and the other closed. Air then flows past the inlet poppet on valve element A, into crossflow passage D, but is substantially blocked by the spool portion of element B. The large size of the open exhaust passage past element B keeps the pressure at the outlet port below 2% of inlet pressure. Full sensing air pressure from side A goes to sensor SA, and a reduced pressure goes to sensor SB. This full pressure signal causes SA to open. Sensor SB, with a reduced pressure signal, does not open. An external monitoring system can detect the malfunction by monitoring the outputs of the SA and SB sensors. The external monitor system must then react accordingly by shutting down the power to the valve solenoids and any other components deemed necessary to stop the machine.

B
Global Air Preparation
Introduction
Filters
Coalescers
Regulators
Filter / Regulators
Lubricators
Combinations
Accessories and Kits



Safety Exhaust Valves

Machinery Directive - Overview

The Machinery Directives' goal is to protect people and the environment from accidents caused from all types of machinery. Based on the standard EN 13849 [safety of machines; safety-related parts of control systems] these standards build the procedure to assess safety-related control systems.

Required Performance Level (PLr) based on a risk assessment are now commonly used to determine the safety level required for the controls system, for the application of machinery.

Performance Level (PL) based on the original B, 1,2,3,4 safety categories, diagnostic capabilities, Mean time to dangerous failure (MTTFd), and common cause failure (CCF), define safety levels of a given safety function. This ensures that safety is not just focused on component reliability, but instead introduces common sense safety principles such as redundancy, diversity, and fail-safe behavior of safety related control parts.

The new EN 13849 standards of the Machinery Directive dictates the machine is safe when the Performance Level of the safety control circuit is equal to or greater than the Required Performance Level of the application. When determining the required performance level, the greater the risk, the higher the requirements of the control system.

$$PL_r \leq PL$$

Determining PLr According to EN 13849-1

The level of each hazardous situation is classified in five Performance levels from a to e. With PL a the control functions contribution to risk reduction is low, while at PL e it is high. The risk graph above can be used as a guideline to determine the required performance level PLr for safety function.

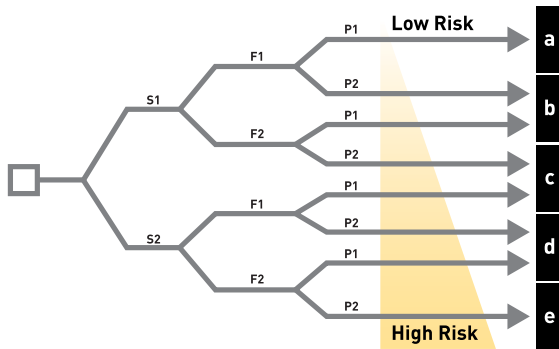

Risk Parameters

(S) Severity of injury

- S1 Slight (normally reversible injury)
- S2 Serious (normally irreversible injury, or death)

(F) Frequency and / or duration of exposure to hazard

- F1 Seldom to less often and / or brief
- F2 Frequent to continuous and / or long

(P) Possibility of avoiding the hazard

- P1 Possibility of avoiding the hazard
- P2 Scarcely ever possible

Determining PL According to EN 13849-1

Determining the MTTF_d = Mean Time To Dangerous Failure

| | | | | | | | | | | |
|--|------------------|------------------|-----------------------|--------------------------|-----------------------|--------------------------|------------------|--|--|--|
| Determining the PL = Performance Level | a | | | | | | | | 10 ⁻³ ≤ PFH _d < 10 ⁻⁴ | Determining the SIL = Safety Integrity Level |
| | b | | | | | | | | 3 X 10 ⁻⁴ ≤ PFH _d < 10 ⁻³ | |
| | c | | | | | | | | 10 ⁻⁴ ≤ PFH _d < 3 X 10 ⁻⁴ | |
| | d | | | | | | | | 10 ⁻⁷ ≤ PFH _d < 10 ⁻⁶ | |
| | e | | | | | | | | 10 ⁻⁶ ≤ PFH _d < 10 ⁻⁷ | |
| | DC < 60% None | DC < 60% None | 60% ≤ DC < 90% Low | 90% ≤ DC < 99% Medium | 60% ≤ DC < 90% Low | 90% ≤ DC < 99% Medium | 99% ≤ DC High | | | |
| | Cat. B | Cat. 1 | Cat. 2 | | Cat. 3 | | Cat. 4 | | | |
| | CCF not relevant | | CCF ≥ 65% | | | | | | | |

Categories Defined by EN 13849-1

| Category | Summary |
|------------|---|
| Category B | When a fault occurs it can lead to the loss of the safety function. |
| Category 1 | Same that Category B, but loss of the safety function is less likely thanks to a good MTTFd of each channel. |
| Category 2 | System behavior allow that the occurrence of a fault can lead to the loss of the safety function between the checks; the loss of the safety function is detected by the check. |
| Category 3 | A single fault in any of safety related parts does not lead to the loss of the safety function. Whenever reasonably possible the single fault shall be detected at or before the next demand upon the safety function. (Means redundancy) |
| Category 4 | Same as Category 3, but if detection of single fault is not possible on or before the next demand upon the safety, an accumulation of these undetected faults shall not lead to the loss of the safety function. (Means redundancy & check) |

Ball Valve / Lockout Valve

The Ball / Lockout Valve shuts off downstream line pressure in the closed position with a 90° turn of the handle. In the closed position, inlet air pressure is blocked and downstream / system air is exhausted through a threaded port. To prevent unauthorized adjustment, the padlock slide may be assembled on either side. It is recommended that this slide is installed after final system assembly.

The Safety Lockout valves conform to OSHA #29 CFR part 1910 — control of hazardous energy source (lockout / tagout).

Note: This padlock slide is a permanent assembly and may not be removed later, any unauthorized tampering will void any warranty claims. The valve can only be locked in the closed position.

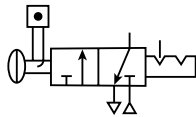
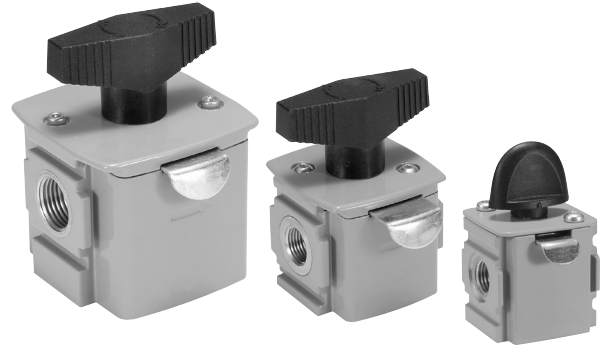

Operating information

| | |
|------------------------|--------------------------------|
| Operating temperature: | -40°C to 80°C (-40°F to 176°F) |
| Pressure supply (max): | 250 psig (17 bar) |
| Port size: | BSPP / BSPT / NPT |
| | 1/4, 3/8, 1/2, 3/4 |
| Weight: | P31 0.33 lbs (0.15 kg) |
| | P32 0.79 lbs (0.36 kg) |
| | P33 1.21 lbs (0.55 kg) |

Ordering Information

| Model Type | Port Size | Exhaust Port | Thread Type | Flow scfm (dm ³ /s, ANR) | Modular Ball Valve Flow from Left to Right |
|------------|-----------|--------------|-------------|-------------------------------------|--|
| P31 | 1/4" | 1/4" | NPT | 42.4 (20) | P31VB92LBNN |
| P32 | 3/8" | 1/4" | NPT | 190.7 (90) | P32VB93LBNN |
| | 1/2" | 1/4" | NPT | 258.5 (122) | P32VB94LBNN |
| P33 | 1/2" | 1/2" | NPT | 561.5 (265) | P33VB94LBNN |
| | 3/4" | 1/2" | NPT | 678 (320) | P33VB96LBNN |

* Lockout tab and muffler supplied with unit.
For thread type: BSPP **1**
BSPT **2**
NPT **9**

Material Specifications

| | |
|-------------|-------------------|
| Body | Aluminum |
| Seals | PTFE |
| Ball | Stainless Steel |
| Lockout Tab | Zinc Plated Steel |
| Screw | Zinc Plated Steel |

Dimensions inches (mm)

P31

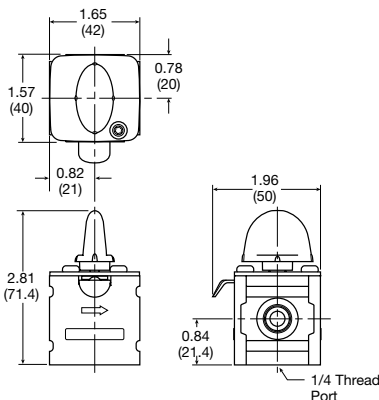

P32

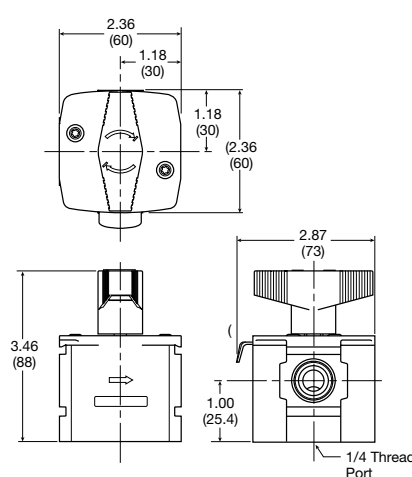

P33

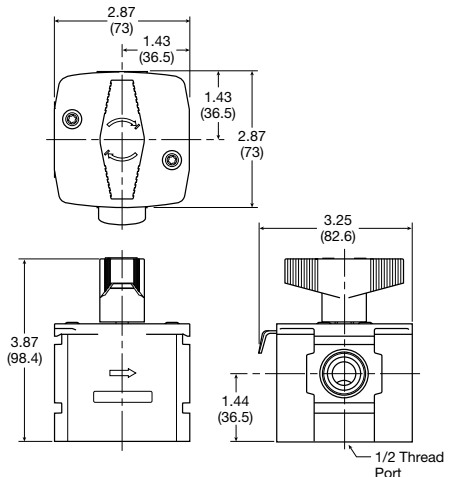

Most popular.

B

Global Air Preparation

Introduction

Filters

Coalescers

Regulators

Filter / Regulators

Lubricators

Combinations

Accessories and Kits



Manifold Blocks

- Available in 1/4" or 3/4" threaded inlet / outlet ports
- Two additional top and bottom auxiliary ports standard
- Can be mounted anywhere in the FRL system

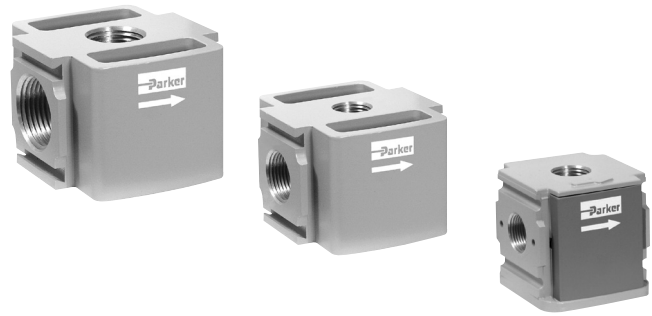
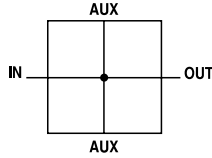

Ordering Information

| Model Type | In / Out Port Size | Auxiliary Port Size Top | Auxiliary Port Size Bottom | Thread Type | Part Number |
|------------|--------------------|-------------------------|----------------------------|-------------|--------------------|
| P31 | 1/4" | 1/4" | 1/4" | NPT | P31MA92022N |
| P32 | 1/2" | 1/4" | 1/2" | NPT | P32MA94024N |
| P33 | 3/4" | 1/4" | 1/2" | NPT | P33MA96024N |

For thread type: BSPP **1**
BSPT **2**
NPT **9**

Operating information

| | |
|------------------------|----------------------------------|
| Operating temperature: | -40°F to 150°F (-40°C to 65.5°C) |
| Pressure supply (max): | 300 psig (20.7 bar) |
| Weight: | P31 0.26 lbs (0.12 kg) |
| | P32 0.45 lbs (0.20 kg) |
| | P33 0.45 lbs (0.20 kg) |

Material Specifications

Body Aluminum

Dimensions inches (mm)

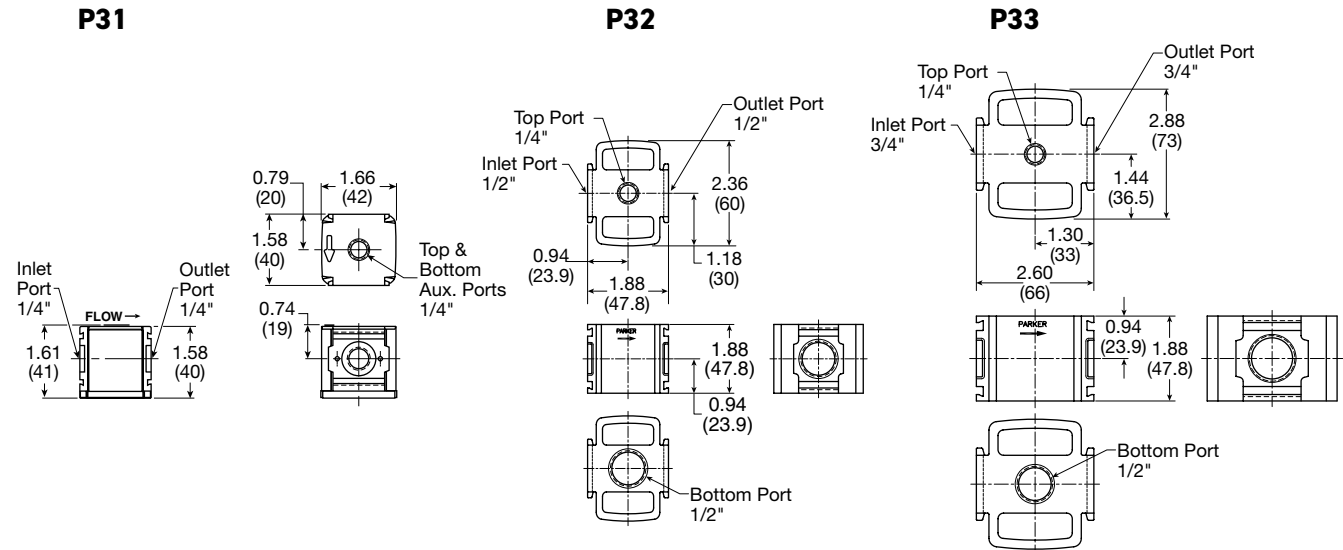

 Most popular.



PPS1 Pressure Switch

- Long life elastomer diaphragm
- High quality snap action switch
- Field adjustable
- Compact design
- Easily customized
- Quick delivery
- NEMA 4, 13

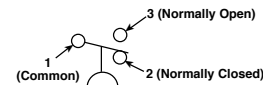

Definitions and Terminology

Repeatability — Accuracy is the maximum allowable set point deviation of a single pressure or temperature switch under one given set of environmental and operational conditions.

Single Pole Double Throw (SPDT) Switching element — A SPDT switching element has one normally open, one normally closed and one common terminal. Three terminals mean that the switch can be wired with the circuit either normally open (NO), or normally closed (NC), or both.

Dead Band — The dead band, sometimes referred to as “differential” or “hysteresis”, is the change in pressure between actuation and deactuation set points.

Operating information

| | |
|---------------------------|--|
| Temperature range: | -40°F to 105°F (-40°C to 220°C) |
| Operating pressure range: | 1, 2, 3 - 250 PSI (17.2 bar) 4 - 2000 PSI (137.9 bar) |
| Set point tolerance | ± 1 PSI or 5% (.07 bar) |
| Deadband | 10 - 20% of set pressure |
| Current rating | 3A @ 125 VAC 2A @ 30 VDC (Resistive) |
| Circuit form | SPDT Standard |
| Cycle life | 1 Million |

Ordering Information:

| PPS1 | - | 1 | C | 3 | - | R | HM | | | | | | | | | | | | | | | | | | | | |
|-----------------------|----------------|---|----------|-------------------------------------|----------|---------------|-----------|---|---|----------------|----|----------------|----------|---|----------|---------------------|------------|----|-------------|---|--|-----------------------|--|----|-----------|----|----------------|
| | | <table border="1"> <thead> <tr><th>Thread</th><th></th></tr> </thead> <tbody> <tr><td>1/4" NPT Male</td><td>1</td></tr> <tr><td>1/8" NPT Male</td><td>2</td></tr> <tr><td>1/4" BSPP Male</td><td>17</td></tr> <tr><td>1/8" BSPP Male</td><td>18</td></tr> </tbody> </table> | | Thread | | 1/4" NPT Male | 1 | 1/8" NPT Male | 2 | 1/4" BSPP Male | 17 | 1/8" BSPP Male | 18 | <table border="1"> <thead> <tr><th>Set Point Direction</th><th></th></tr> </thead> <tbody> <tr><td>R</td><td>Rising</td></tr> </tbody> </table> | | Set Point Direction | | R | Rising | <table border="1"> <thead> <tr><th>Electrical Connection</th><th></th></tr> </thead> <tbody> <tr><td>HM</td><td>DIN 9.4mm</td></tr> <tr><td>WL</td><td>Wire Leads 18"</td></tr> </tbody> </table> | | Electrical Connection | | HM | DIN 9.4mm | WL | Wire Leads 18" |
| Thread | | | | | | | | | | | | | | | | | | | | | | | | | | | |
| 1/4" NPT Male | 1 | | | | | | | | | | | | | | | | | | | | | | | | | | |
| 1/8" NPT Male | 2 | | | | | | | | | | | | | | | | | | | | | | | | | | |
| 1/4" BSPP Male | 17 | | | | | | | | | | | | | | | | | | | | | | | | | | |
| 1/8" BSPP Male | 18 | | | | | | | | | | | | | | | | | | | | | | | | | | |
| Set Point Direction | | | | | | | | | | | | | | | | | | | | | | | | | | | |
| R | Rising | | | | | | | | | | | | | | | | | | | | | | | | | | |
| Electrical Connection | | | | | | | | | | | | | | | | | | | | | | | | | | | |
| HM | DIN 9.4mm | | | | | | | | | | | | | | | | | | | | | | | | | | |
| WL | Wire Leads 18" | | | | | | | | | | | | | | | | | | | | | | | | | | |
| | | <table border="1"> <thead> <tr><th>Circuit</th><th></th></tr> </thead> <tbody> <tr><td>SPDT</td><td>C</td></tr> </tbody> </table> | | Circuit | | SPDT | C | <table border="1"> <thead> <tr><th>Range*</th><th></th></tr> </thead> <tbody> <tr><td>1</td><td>3-10 PSI</td></tr> <tr><td>2</td><td>6-30 PSI</td></tr> <tr><td>3</td><td>20-120 PSI</td></tr> <tr><td>4†</td><td>100-400 PSI</td></tr> </tbody> </table> | | Range* | | 1 | 3-10 PSI | 2 | 6-30 PSI | 3 | 20-120 PSI | 4† | 100-400 PSI | <p>* Factory setting for calibration purposes Range 1 = 6 PSI Range 2 = 18 PSI Range 3 = 70 PSI Range 4 = 250 PSI</p> | | | | | | | |
| Circuit | | | | | | | | | | | | | | | | | | | | | | | | | | | |
| SPDT | C | | | | | | | | | | | | | | | | | | | | | | | | | | |
| Range* | | | | | | | | | | | | | | | | | | | | | | | | | | | |
| 1 | 3-10 PSI | | | | | | | | | | | | | | | | | | | | | | | | | | |
| 2 | 6-30 PSI | | | | | | | | | | | | | | | | | | | | | | | | | | |
| 3 | 20-120 PSI | | | | | | | | | | | | | | | | | | | | | | | | | | |
| 4† | 100-400 PSI | | | | | | | | | | | | | | | | | | | | | | | | | | |
| | | | | <p>† Only available in 1/4" NPT</p> | | | | | | | | | | | | | | | | | | | | | | | |

Note: Switch is field adjustable.

Material Specifications

| | |
|-----------------|-------------------|
| Adjustment knob | Anodized aluminum |
| Body | Brass |
| Diaphragm | Nitrile |

Operation

The pressure switch monitors the air pressure in your pneumatic system. When the pressure in your system either drops below or exceeds the set point pressure, an electrical output is given.

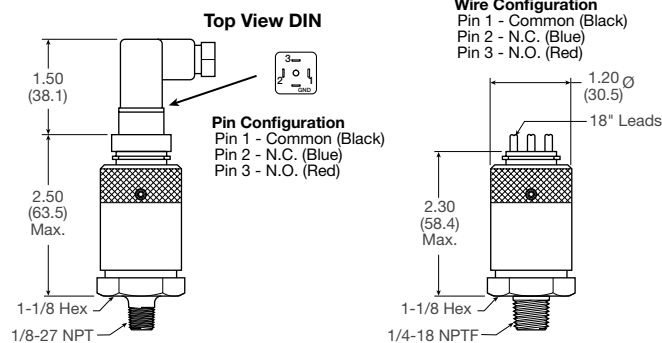
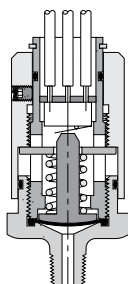

P31 Accessories

C-Bracket
(Fits to filter and lubricator body)
P31KA00MW

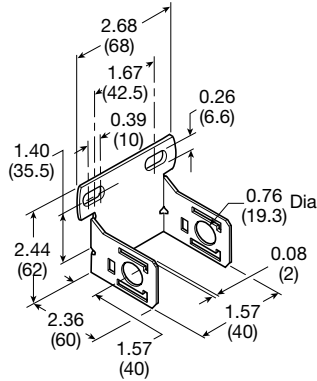

T-Bracket w/ Body Connector
(O-ring not shown)
P31KA00MT

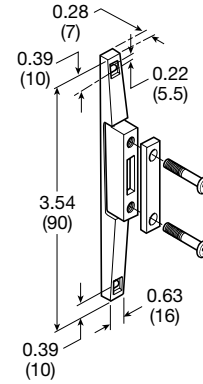

Body Connector
(O-ring not shown)
P31KA00CB

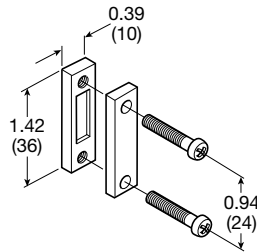
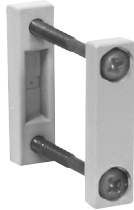

Port Block Kit
(O-ring not shown)

- | | | | |
|----------------|------------------|----------------|------------------|
| 1/8 NPT | P31KA91CP | 1/8 BSPT | P31KA21CP |
| 1/4 NPT | P31KA92CP | 1/4 BSPT | P31KA22CP |
| 3/8 NPT | P31KA93CP | 3/8 BSPT | P31KA23CP |
| 1/8 BSPP | P31KA11CP | | |
| 1/4 BSPP | P31KA12CP | | |
| 3/8 BSPP | P31KA13CP | | |



Port Block Kit w/ T-Bracket
(O-ring not shown)

- | | | | |
|----------------|------------------|----------------|------------------|
| 1/8 NPT | P31KA91CN | 1/8 BSPT | P31KA21CN |
| 1/4 NPT | P31KA92CN | 1/4 BSPT | P31KA22CN |
| 3/8 NPT | P31KA93CN | 3/8 BSPT | P31KA23CN |
| 1/8 BSPP | P31KA11CN | | |
| 1/4 BSPP | P31KA12CN | | |
| 3/8 BSPP | P31KA13CN | | |



Angle Bracket
(Fits to regulator and filter/regulator body)
P31KB00MR

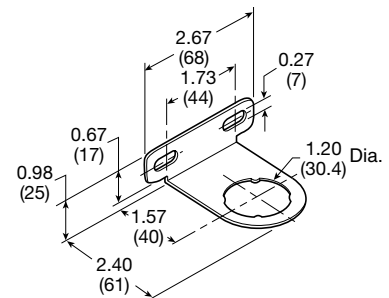

P32 Accessories

T-Bracket w/ Body Connector

P32KA00MT

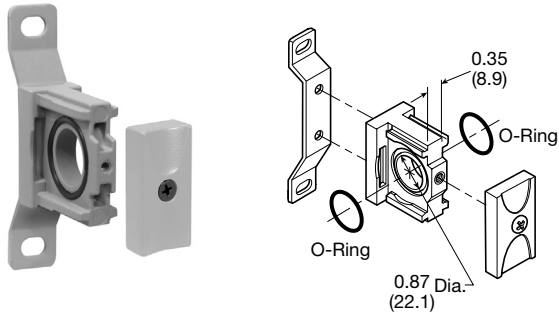

Body Connector

P32KA00CB

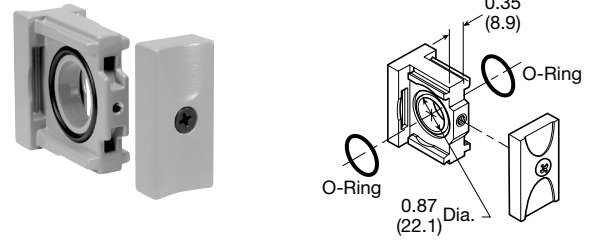

Port Block Kit

| | | | |
|----------------|------------------|----------------|------------------|
| 1/4 NPT | P32KA92CP | 1/4 BSPT | P32KA22CP |
| 3/8 NPT | P32KA93CP | 3/8 BSPT | P32KA23CP |
| 1/2 NPT | P32KA94CP | 1/2 BSPT | P32KA24CP |
| 3/4 NPT | P32KA96CP | 3/4 BSPT | P32KA26CP |
| 1/4 BSPP | P32KA12CP | | |
| 3/8 BSPP | P32KA13CP | | |
| 1/2 BSPP | P32KA14CP | | |
| 3/4 BSPP | P32KA16CP | | |



Angle Bracket

(Fits to regulator and filter/regulator bonnet)

P32KB00MR

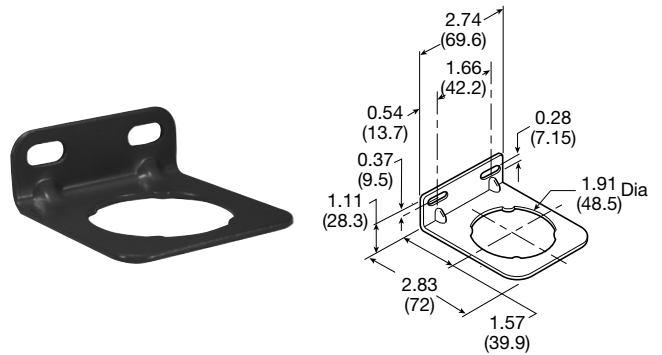

L-Bracket

(Fits to filter and lubricator body)

P32KA00ML

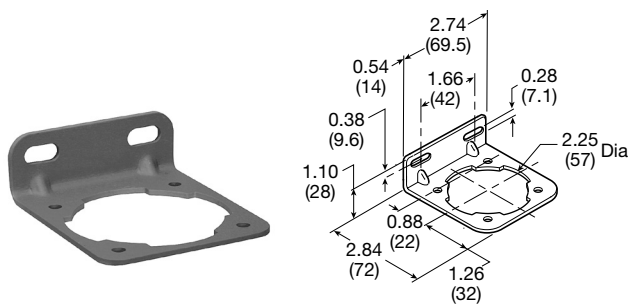

T-Bracket

(fits to body connector or port block)

P32KA00MB

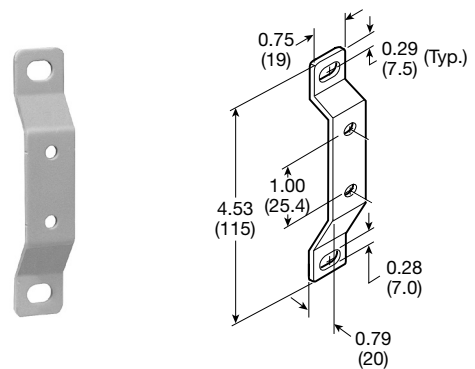

B
Global Air
Preparation

Introduction

Filters

Coalescers

Regulators

Filter /
Regulators

Lubricators

Combinations

Accessories
and Kits



P33 Accessories

T-Bracket w/ Body Connector

P32KA00MT

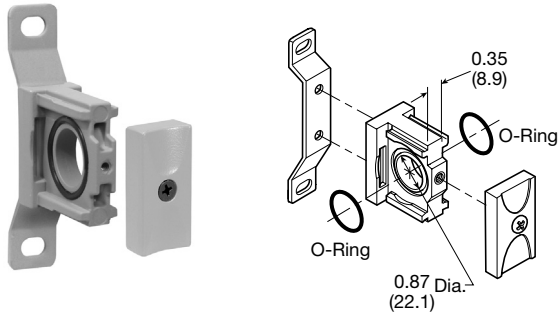

Body Connector

P32KA00CB

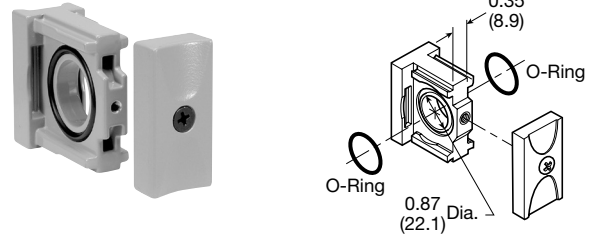

Port Block Kit

- | | | | |
|----------------|------------------|----------------|------------------|
| 1/4 NPT | P32KA92CP | 1/4 BSPT | P32KA22CP |
| 3/8 NPT | P32KA93CP | 3/8 BSPT | P32KA23CP |
| 1/2 NPT | P32KA94CP | 1/2 BSPT | P32KA24CP |
| 3/4 NPT | P32KA96CP | 3/4 BSPT | P32KA26CP |
| 1/4 BSPP | P32KA12CP | | |
| 3/8 BSPP | P32KA13CP | | |
| 1/2 BSPP | P32KA14CP | | |
| 3/4 BSPP | P32KA16CP | | |



Angle Bracket

(Fits to regulator and filter/regulator bonnet)

P33KA00MR

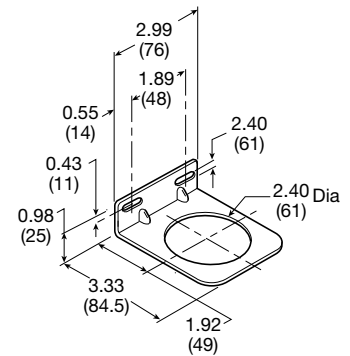

L-Bracket

(Fits to filter and lubricator body)

P33KA00ML

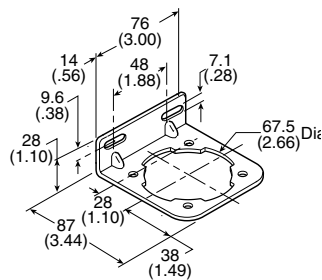

T-Bracket





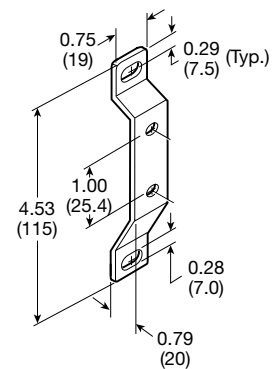





(fits to body connector or port block)

P32KA00MB



Air Preparation Products Global Air Preparation

Accessories

| Series | Description | Part number | |
|-------------------|--|---|---|
| P31 P32 P33 | Panel Mount Nut (Plastic) | P31KA00MP P32KA00MP P33KA00MP |  |
| P31 P32 P33 | Panel Mount Nut (Aluminum) | P31KA00MM P32KA00MM P33KA00MM |  |
| P31 P32 P33 | 5μ Element Kit | P31KA00ESE P32KA00ESE P33KA00ESE |  |
| P31 P32 P33 | 1μ Element Kit | P31KA00ES9 P32KA00ES9 P33KA00ES9 |  |
| P31 P32 P33 | 0.01μ Element Kit | P31KA00ESC P32KA00ESC P33KA00ESC |  |
| P31 P32 P33 | Adsorber Element Kit | P31KA00ESA P32KA00ESA P33KA00ESA |  |
| P32 / P33 | Auto Drain Kit | P32KA00DA |  |
| P31 P32 / P33 | Differential Pressure Indicator Kit | P31KB00RQ P32KA00RQ |  |
| P31 / P32 / P33 | Drip Control Assembly Kit - Nylon Drip Control Assembly Kit - Polycarbonate | P32KA00PH P32KA00PG |  |
| P31 P32 / P33 | Fill Plug Kit | P31KA00PL P32KA00PL |  |
| P31 P32 P33 | Lubricator - Plastic Bowl w/ Bowl Guard No Drain | P31KB00BGN P32KB00BGN P33KA00BGN |  |

B

Global Air
Preparation

Introduction

Filters

Coalescers

Regulators

Filter /
Regulators

Lubricators











Combinations

Accessories
and Kits



Accessories

Air Preparation Products Global Air Preparation

| Series | Description | Part number | |
|-------------------|--|---|---|
| P31 P32 P33 | Lubricator - Metal Bowl w/o Sight Gauge No Drain | P31KB00BMN P32KB00BMN P33KA00BMN |  |
| P32 P33 | Lubricator - Metal Bowl w/ Sight Gauge No Drain | P32KB00BSN P33KA00BSN |  |
| P31 P32 P33 | Metal Bowl w/o Sight Gauge & Manual Drain | P31KB00BMM P32KB00BMM P33KA00BMM |  |
| P31 | Metal Bowl w/o Sight Gauge & Pulse Drain | P31KB00BMB |  |
| P32 P33 | Metal Bowl w/o Sight Gauge & Auto Drain | P32KB00BMA P33KA00BMA |  |
| P32 P33 | Metal Bowl w/ Sight Gauge & Manual Drain | P32KB00BSM P33KA00BSM |  |
| P32 P33 | Metal Bowl w/ Sight Gauge & Auto Drain | P32KB00BSA P33KA00BSA |  |
| P31 P32 P33 | Plastic Bowl w/ Bowl Guard & Manual Drain | P31KB00BGM P32KB00BGM P33KA00BGM |  |
| P31 | Plastic Bowl w/ Bowl Guard & Pulse Drain | P31KB00BGB |  |
| P32 P33 | Plastic Bowl w/ Bowl Guard & Auto Drain | P32KB00BGA P33KA00BGA |  |
| P33 | Regulator - Relieving Repair Kit | P33KA00RB | |
| P33 | Regulator - Non-Relieving Repair Kit | P33KA00RC | |

B

 Global Air
Preparation

Introduction

Filters

Coalescers

Regulators

 Filter /
Regulators



Lubricators

Combinations

 Accessories
and Kits

Air Preparation Products Global Air Preparation

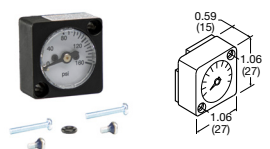
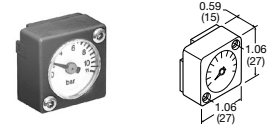
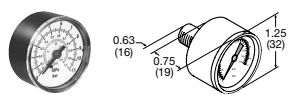
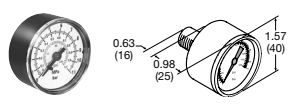
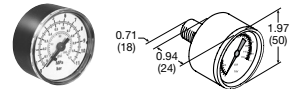
Accessories

| Series | Description | Connection | Part number | | |
|------------------|--|---|---|--|---|
| P33 | Regulator - Main Adjusting Spring 0-30 psig (0-2 bar) Kit | | P33KA00PR | | |
| P33 | Regulator - Main Adjusting Spring 0-60 psig (0-4.1 bar) Kit | | P33KA00PS | | |
| P33 | Regulator - Main Adjusting Spring 0-125 psig (0-8.6 bar) Kit | | P33KA00PT | | |
| P33 | Regulator - Main Adjusting Spring 0-250 psig (0-17 bar) Kit | | P33KA00PV | | |
| P31 | Square Gauge | 0-60 psig 0-160 psig 0-290 psig 0-4 bar 0-11 bar 0-20 bar 0-0.4 MPa 0-1.1 MPa 0-2.0 MPa | P31KA060XB P31KA160KB P31KA290XB P31KA04BXB P31KA11BXB P31KA20BXB P31KA04MXB P31KA11MXB P31KA20MXB |  | |
| P31 | Square Flush Mounting Gauge Kit | 0-60 psig 0-160 psig 0-4 bar 0-11 bar | K4511SCR060 K4511SCR160 K4511SCR04B K4511SCR11B |  | |
| P31 / P32 | Square Mounting Gauge with Adapter Kit | 0-60 psig 0-160 psig 0-4 bar 0-11 bar | P6G-PR90060 P6G-PR90160 P6G-PR10040 P6G-PR10110 | | |
| P31 | 1" Round Gauge | 0-60 psig / 0-4.1 bar 0-160 psig / 0-10 bar | 1/8" 1/8" | K4510N18060 K4510N18160 |  |
| P31 | 40mm Round Gauge | 0-30 psig / 0-2 bar 0-60 psig / 0-4.1 bar 0-160 psig / 0-10 bar | 1/8" 1/8" 1/8" | K4515N18030 K4515N18060 K4515N18160 |  |
| P32 / P33 | 50mm Round Gauge | 0-30 psig / 0-2 bar 0-60 psig / 0-4.1 bar 0-160 psig / 0-10 bar 0-300 psig / 0-20 bar | 1/4" 1/4" 1/4" 1/4" | K4520N14030 K4520N14060 K4520N14160 K4520N14300 |  |
| P31 P32 / P33 | Body Connector O-ring (Replacement kit) (Pack of 10) | | | P31KA00CY P32KA00CY |  |
| P31 P32 | Tamperproof Lockable Kit | | | P31KB00AL P32KB00AL |  |

B

Global Air
Preparation

Introduction

Filters

Coalescers

Regulators

Filter /
Regulators

Lubricators

Combinations

Accessories
and Kits



Solenoid Operators - CNOMO

Solenoid operators, coil combinations

| | NC Normal Operator with 22 x 30 standard coil | NC Normal Operator with 30 x 30 standard coil |
|---------------------|---|---|
| Working pressure | 0 to 10 bar | 0 to 10 bar |
| Ambient temperature | -10°C to 60°C * | -10°C to 60°C * |
| Power (DC) | 4.8W | 2.7W |
| Power (AC) | 8.5VA | 4.9VA |
| Voltage tolerance | +/- 10% | +/- 10% |
| Duty cycle | 100% | 100% |
| Insulation class | F | F |
| Electric connection | B Industrial | DIN 43650A |
| Protection | IP65 | IP65 |
| Approval | | UL/CSA |
| Working media | All neutral media such as compressed air | |

* Limited to 50°C if use with 100% duty cycle

P31 Series only - Solenoid coils 15mm NC

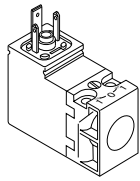

| Voltage | Order code Override, blue, non-locking flush | Weight (kg) |
|------------------------------|--|----------------|
| 24VDC | PS2982B49P | 0.038 |
| 115VAC 50Hz / 120VAC 60Hz | PS2982B53P | 0.038 |

Solenoid Coils with M12 Connection

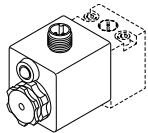

| Voltage | Part number | Weight (kg) |
|----------------|-----------------|----------------|
| Direct current | | |
| 24VDC | P2FC6449 | 0.065 |

Solenoid Coils with DIN A or Industrial B Connection

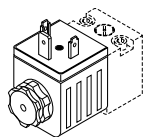

| Voltage | 22mm x 30mm Part number B industrial standard | Weight (kg) | 30mm x 30mm Part number DIN 43650A standard | Weight (kg) |
|----------------------|--|----------------|--|----------------|
| Direct current | | | | |
| 24VDC | P2FCB449 | 0.093 | P2FCA449 | 0.105 |
| Alternative current | | | | |
| 110V 50Hz, 120V 60Hz | P2FCB453 | 0.093 | P2FCA453 | 0.105 |

 Most popular.

Transients

Interrupting the current through the solenoid coil produces momentary voltage peaks which, under unfavorable conditions, can amount to several hundred times the rated operating voltage. Normally, these transients do not cause problems, but to achieve the Maximum life of relays in the circuit (and particularly of transistors, thyristors and integrated circuits) it is desirable to provide protection by means of voltage-dependent resistors (varistors). All connectors/cable plugs EN175301-803 with LED's include this type of circuit protection.

Materials

Pilot Valve

| | |
|-----------------|---------------------------------|
| Body: | Polyamide |
| Armature tube: | Brass |
| Plunger & core: | Corrosion resistant Cr-Ni steel |
| Seals: | Fluorocarbon |
| Screws: | Stainless steel |

Coil

| | |
|-------------------------|---|
| Encapsulation material: | Thermoplastic as standard Duroplast for M12 connection |
|-------------------------|---|

Spare Base Solenoid Pilot Operator CNOMO NC

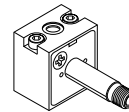

| Description | Part number non-lock manual override | Weight (kg) |
|---------------|---|----------------|
| Standard Duty | P2FP23N4B | 0.065 |
| No Override | P2FP23N4A | 0.065 |

Note: Solenoid pilot operators are fitted to the Global range. Order the above part numbers for spares. The operators are supplied with mounting screws and interface 'O' rings. Coils and connectors must be ordered separately.



Accessories

Solenoid Connectors / Cable Plugs EN175301-803

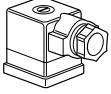
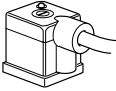
| | Description | Part number | Part number |
|--|---|------------------------|------------------------|
| | | 22mm Form B Industrial | 30mm Form A DIN 43650A |
|  With standard screw | Standard IP65 without flying lead | PS2429BP | PS2028BP |
| | With LED and protection 24VAC/DC | PS243079BP | PS203279BP |
| | With LED and protection 110VAC | PS243083BP | PS203283BP |
|  With cable | Standard with 2m cable IP65 | PS2429JBP | PS2028JCP |
| | 24VAC/DC, 2m cable LED and protection IP65 | PS2430J79BP | PS2032J79CP |
| | 110VAC/DC, 2m cable LED and protection IP65 | PS2430J83BP | PS2032J83CP |

Solenoid coil dimensions inches (mm)

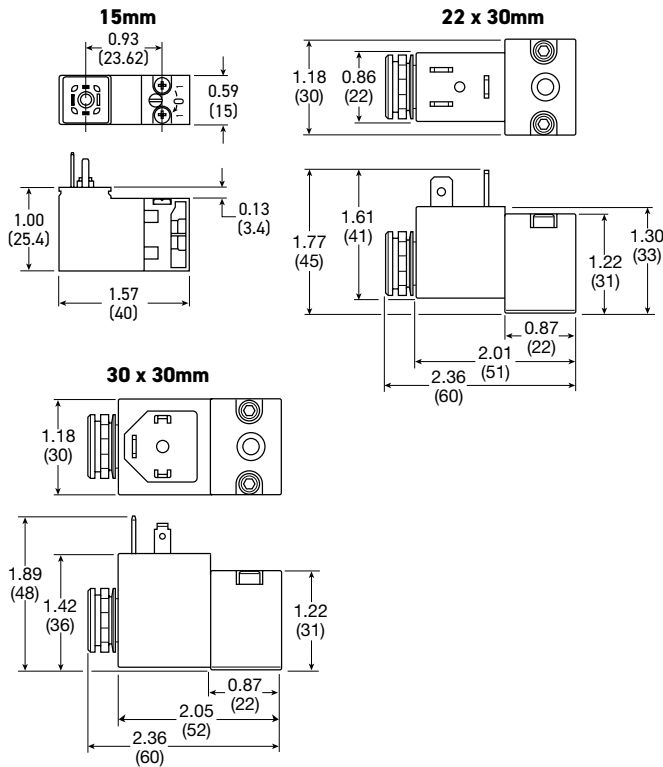

Electrical schematics

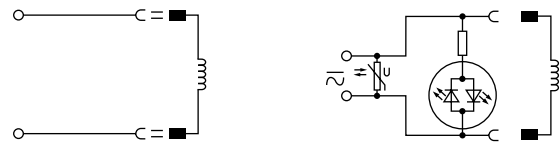

| | | |
|------------------|--------------------|--------------------|
| PS2028BP | PS243079BP | PS203279BP |
| PS2028JBP | PS2430J79BP | PS2032J79CP |
| PS2429BP | PS243083BP | PS203283BP |
| PS2429JBP | PS2430J83BP | PS2032J83CP |
| PS2932BP | PS294679BP | PS294683BP |
| PS2932JBP | PS2946J79BP | PS2946J83BP |

Cable plug dimensions inches (mm)

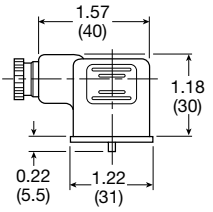
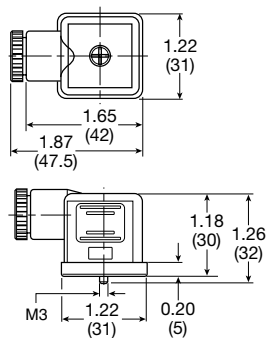
| 22mm Form B Industrial Cable plugs | PS2429BP | 30mm DIN 43650A Cable plugs | PS2028BP |
|---|----------|--|----------|
|  1.57 (40) x 1.18 (30) x 0.22 (5.5) x 1.22 (31) x 0.82 (20.8) | |  1.22 (31) x 1.65 (42) x 1.87 (47.5) x 1.18 (30) x 1.26 (32) x 0.20 (5) x 1.22 (31) | |

Most popular.

