

Series 2

ANGULAR ENCODERS

FAGOR
AUTOMATION



Open
to your
world



FAGOR

AUTOMATION



Open
to your
world

Angular and rotary encoders

Over 40 years of continuous evolution





Fagor Automation has been manufacturing high quality angular and rotary encoders using precision optical technology for more than 40 years.

Over the years Fagor has created, developed and patented systems, components and technologies that allow us to offer best quality and features over the complete range of product utilizing innovative production methods.

Hence making Fagor Automation the most efficient alternative in the world of feedback systems.

Modern facilities and innovative processes

In order to ensure quality and reliability in all its products Fagor Automation utilizes the most advanced technology and testing and manufacturing facilities. From centralized computer control temperature monitoring, cleanliness and relative humidity control, a must for the feedback system manufacturing process, to laboratories for climate, vibration and EMC testing to certify the designs.



With state-of-the-art technology

Fagor Automation's commitment to this technology and quality is evident by creation of **Aotek** in 2002, a dedicated research center providing various technological breakthroughs. This investment has resulted in large number of patents and customized solutions in electrical, optical and mechanical fields.

3Statech
Technology

 PATENTED
BY FAGOR

Optical reading technology

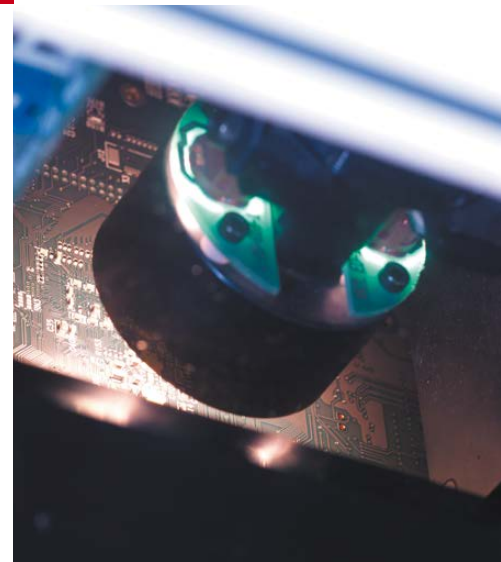

Superior technology and innovative design

Fagor Automation develops with maximum professionalism the three cornerstones in encoder design: optical design, electronic design and mechanical design that result in a state-of-the-art product.

Optical design

At the forefront of measurement technologies, Fagor Automation uses both optical transmission and reflection in its range of encoders.

With new scanning techniques, such as the new single-window scanning technology, more immune to contamination, which is critical for operations in extreme conditions, and contributes to attaining high quality signals that minimize interpolation errors, resulting in improved accuracy of the measurement system.

Electronic design

Fagor Automation uses latest generation integrated electronic components in their design. Thanks to that, it achieves the optimization of the signals at high turning speeds, achieving high accuracy and angular resolution.

Mechanical design

Fagor Automation designs and manufactures the most innovative and reliable measuring systems using its advanced mechanical designs. These advanced designs minimize fluid accumulation while facilitating drainage and provide greater resistance to fluids and better sealing with double-flanged o-rings with the VITON® material in their composition. In addition, aid components, such as the markings indicating the positive and negative counting directions, facilitate installation. These designs, together with the materials used – titanium and stainless steel – provide the products with the necessary robustness to ensure the best performance in different applications.

Enclosed design

The enclosed design protects the graduated glass disc. The o-rings and the specifically designed for harsh environments machining on the encoder body protect the encoder from powder and liquid deposits or splashes. The reader head and the graduated disc make up a balance tandem accurately capturing and transmitting the position movement of the machine. The encoder shaft, bonded to the graduated disc, integrates high quality bearings requiring low starting torque at start or during operation. The air intake option increases the degree of protection against powder and fluids.

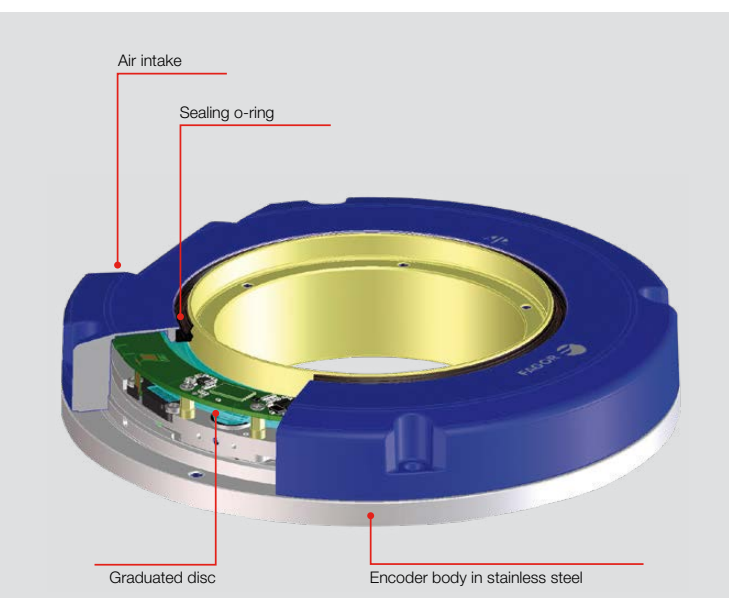
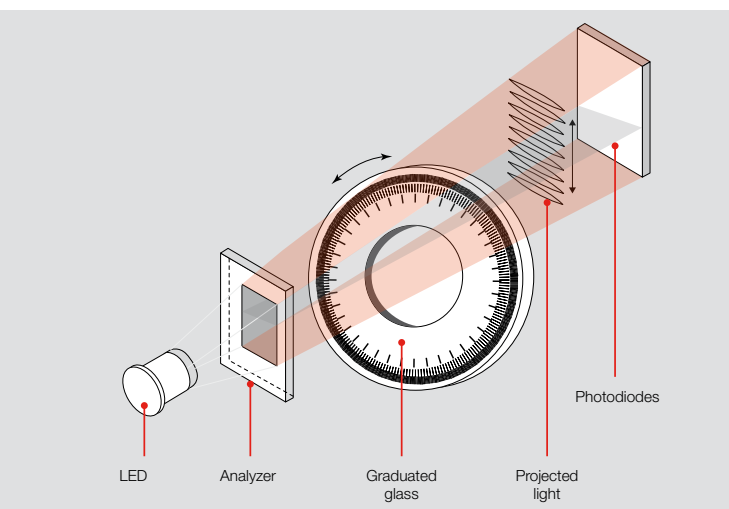

Quality

Accuracy certificate

Every single Fagor encoder is subjected to an extensive final accuracy check. This control is carried out on a computerized measuring bench equipped with a calibrated measuring standard located inside a climate controlled chamber at a temperature of 20°C. The resulting final accuracy graph is supplied with every Fagor encoder.

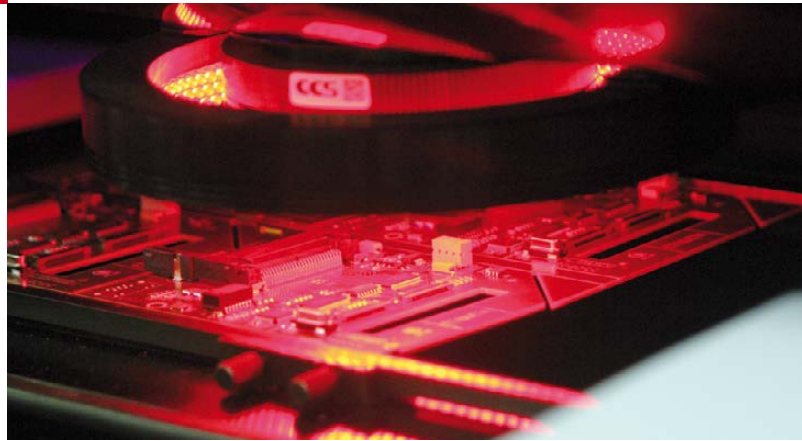

The quality of the measurement is mainly determined by:

- Etching quality
- The quality of the scanning process
- The quality of the electronics that processes the signals



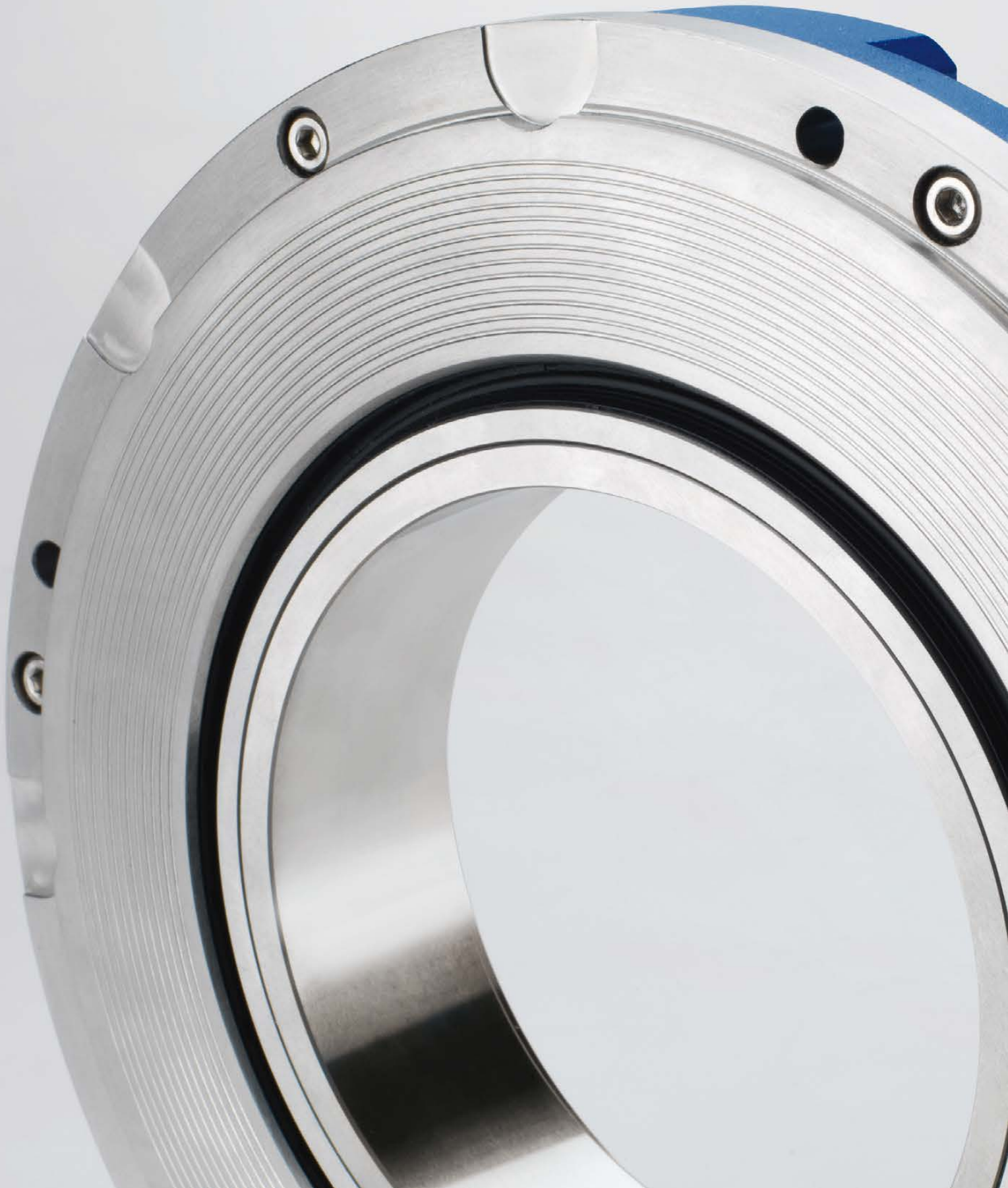

A

ABSOLUTE

Technology and range	10
Signals	12
H2A-D200i100 series	14
H2A-D200 series	16
H2A-D90 series	18
S2A-D170 series	20
S2A-D90 series	22
H2A-D87 series	24
Cables and extension cables	26

I

INCREMENTAL

Technology and range	32
Signals	34
H2-D200 series	36
H2-D90 series	38
S2-D170 series	40
S2-D90 series	42
H series	44
S series	44
Cables and extension cables	46
Accessories	50

Range

Analyze the application to make sure that the proper encoder will be selected for the machine.

To do this, bear in mind the following considerations:

Installation: This point considers the physical dimensions of the installation and the space available for it. It is essential to determine its type of shaft: Hollow or solid.

Accuracy: Each encoder is supplied with a graph showing the accuracy of the angular encoder.

Signal: The signal selection considers the communication protocols compatible with the main CNC and drives manufacturers.

Resolution: The resolution of the control of machine-tools depends on the encoder.

Cable length: The length of the cable depends on the type of signal.

Compatibility: The signal must be compatible with the control system.

Speed: The speed requirements for the application must be analyzed before choosing the encoder.

Shock and Vibration: Fagor's angular encoders can withstand vibrations of up to 100 m/s² and impacts of up to 1000 m/s².

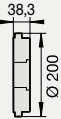
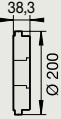
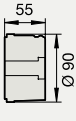
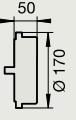
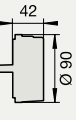
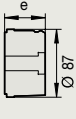
Series	Section
H2A-D200i100	
H2A-D200	
H2A-D90	
S2A-D170	
S2A-D90	
H2A-D87	

e = 49, 55 or 59 depending on the model

Technology

The absolute measurement system is a direct digital measure of machine position. It is fast, accurate and does not require homing of the machine. The position value is available from the moment the machine is turned on and may be requested by the connected device (CNC) at any time.

These encoders provide direct measure of machine position without using any intermediate device. The errors originated in the mechanics of the machine are avoided because the encoder is mounted on the machine axis and sends the real movement data to the controller; some of the potential sources of error, such as those caused by the thermal behavior of the machine, may be minimized using encoders. The graduated glass substrate has two different engravings:

- **Incremental graduation:** Used to generate incremental signals that are counted inside the reader head. The incremental graduation also provides the 1 Vpp analog signals except in systems that only use digital signals.

- **Absolute graduation:** It is a unique code which is imprinted along the measuring length of encoder.

The position in Fagor series 2 absolute encoders is calculated by employing their own patented technology **3Statech Technology**. The working principle is based upon the generation of a third state that can identify contamination in the measurement standard. Overall it means a technological evolution over other developments. The specific characteristics of the engraved code, acquired in a high precision optical sensor and the subsequent decoding in the electronic embedded software allows for the correct position calculation with less information. The **3STATECH** technology provides enhanced resistance to contamination or stains which results in more robust performance of the encoders in hostile working environments.



Type of shaft	Accuracy	Signals	Model	Page
Hollow shaft	± 1" ± 2"	SSI + 1 Vpp FAGOR / SIEMENS® (*)	H2A / H2AS	14
		FANUC® / MITSUBISHI® / PANASONIC® / FAGOR	H2AF / H2AM / H2AP / H2AD	
		SIEMENS® (*)	H2AD + EC-PA-DQ1-M	
		BiSS® C	H2ABC	
Hollow shaft	± 1" ± 2"	SSI + 1 Vpp FAGOR / SIEMENS® (*)	H2A / H2AS	16
		FANUC® / MITSUBISHI® / PANASONIC® / FAGOR	H2AF / H2AM / H2AP / H2AD	
		SIEMENS® (*)	H2AD + EC-PA-DQ1-M	
		BiSS® C	H2ABC	
Hollow shaft	± 2.5" / ± 5"	SSI + 1 Vpp FAGOR / SIEMENS® (*)	H2A / H2AS	18
		FANUC® / MITSUBISHI® / PANASONIC® / FAGOR	H2AF / H2AM / H2AP / H2AD	
	± 2" ± 4"	SIEMENS® (*)	H2AD + EC-PA-DQ1-M	
		BiSS® C	H2ABC	
Solid shaft	± 2"	SSI + 1 Vpp FAGOR / SIEMENS® (*)	S2A / S2AS	20
		FANUC® / MITSUBISHI® / PANASONIC® / FAGOR	S2AF / S2AM / S2AP / S2AD	
		SIEMENS® (*)	S2AD + EC-PA-DQ1-M	
		BiSS® C	S2ABC	
Solid shaft	± 2.5" / ± 5"	SSI + 1 Vpp FAGOR / SIEMENS® (*)	S2A / S2AS	22
		FANUC® / MITSUBISHI® / PANASONIC® / FAGOR	S2AF / S2AM / S2AP / S2AD	
	± 2" ± 4"	SIEMENS® (*)	S2AD + EC-PA-DQ1-M	
		BiSS® C	S2ABC	
Hollow shaft	± 10" ± 20"	SSI + 1 Vpp FAGOR / SIEMENS® (*)	H2A / H2AS	24
		FANUC® / MITSUBISHI® / PANASONIC® / FAGOR	H2AF / H2AM / H2AP / H2AD	
		SIEMENS® (*)	H2AD + XC-C8-PA-DQ-M	
		BiSS® C	H2ABC	

(*) SIEMENS®: valid for family Solution Line and Sinumerik One.

Graduated glass disk

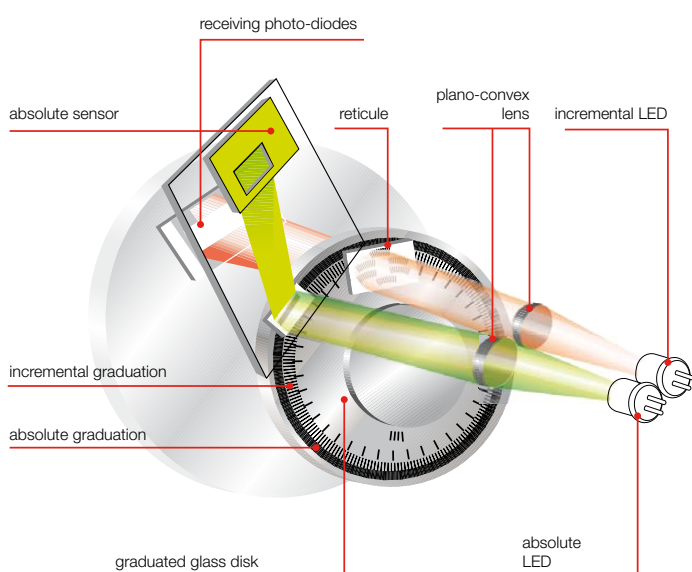

Angular encoders

Angular encoders are used as angular movement sensors on machines that require high resolution and high accuracy.

Fagor angular encoders reach 29-bit angular resolution equivalent to 536 870 912 positions and accuracy levels of ± 5", ± 2.5", ± 2" and ± 1" depending on the model. In them, the graduated disk of the measuring system is attached directly to the shaft. They have bearings and couplings that serve as guide and adjustment.

Couplings, besides minimizing the static and dynamic deviations, compensate for axial movements of the shaft providing easier mounting, smaller size and the possibility of hollow shafts.

Electrical output signals

They are defined according to the communication protocol. Protocols are specific communication languages used by linear encoders to communicate with the machine controller (CNC, drive, PLC, etc.). There are different communication protocols depending on the CNC manufacturer. Fagor Automation offers absolute encoders with different communication protocols compatible with the main CNC manufacturers on the market such as FAGOR, FANUC®, SIEMENS®, MITSUBISHI®, PANASONIC® and others.

absolute

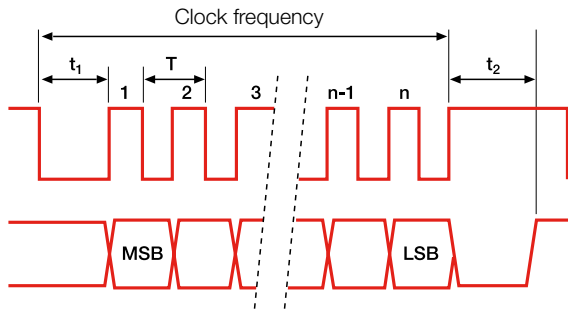

1 Vpp differential

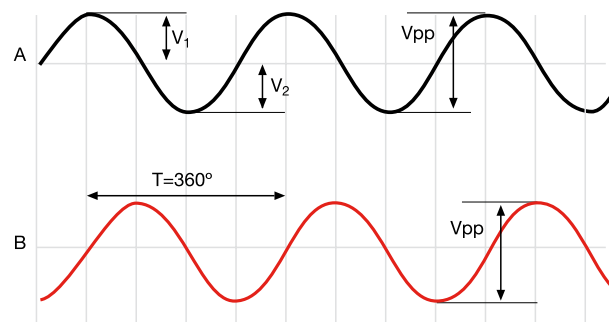

FAGOR systems

Fagor FeeDat® Serial Interface

These systems only use digital signals.

The absolute encoder is connected through QUERCUS drive system.

A high communication speed of 10 MHz provides a loop time of 10 microseconds. Communication also includes alarms, analog signal values and other encoder parameters.

Fagor FeeDat® is an open communication protocol that is also used to communicate with other CNC system manufacturers.

SIEMENS® systems

DRIVE-CLiQ® Interface

These systems only use digital signals.

The absolute encoder is connected through a cable having the electronics integrated into the connector and it is connected to the "Solution Line and Sinumerik One" family without the need for intermediate modules.



Sistemas FANUC®

Serial Interface for position feedback encoder

These systems only use digital signals. The absolute encoder is connected through the SDU (Separate Detector Unit) device and is valid for communication protocol versions FANUC® α and αi serial interface.

MITSUBISHI® systems

High Speed Serial Interface - HSSI

These systems only use digital signals. The absolute encoder is connected through the MDS Series drive and it is valid for MITSUBISHI® communication protocol versions Mit 03-2/4.

PANASONIC® systems

Serial Communication

These systems only use digital signals. These systems only use digital signals. The absolute encoder is connected through the MINAS series drive.

- The systems can be connected to linear motors, rotary motors and DD motors.
- Automatic drive/motor matching software available.
- Vibration, resonance suppression filters available with setting done automatically / manually.
- Drive range from 50 W to 15 kW at AC 100 V / 200 V / 400 V.
- Safety Torque Off feature available.

PANASONIC® systems
A5 series



Systems with SSI or BiSS® C

The SSI or BiSS® C communication interfaces are widely implemented among manufacturers of drive and control systems (FAGOR, SIEMENS®, etc.). These systems and the absolute encoders with SSI or BiSS® C interfaces can be connected as long as they are compatible.

1. Systems with Serial Synchronous Interface - SSI

These systems synchronize the SSI interface with the sinusoidal 1 Vpp signals. Once the absolute position has been obtained through the SSI interface, the encoders keep operating with incremental 1 Vpp signals.

A. FAGOR systems

ABSOLUTE signals

Transmission	SSI synchronous serial transfer via RS 485
Levels	EIA RS 485
Clock frequency	100 kHz - 500 kHz
Max. bit (n)	32
T	1 μs + 10 μs
t ₁	> 1 μs
t ₂	20 μs - 35 μs
SSI	Binary
Parity	No

1 Vpp DIFFERENTIAL signals

Signals	A, /A, B, /B
V _{App}	1 V +20%, -40%
V _{Bpp}	1 V +20%, -40%
DC offset	2.5 V ± 0.5 V
Signal period	360/2048°, 360/16384°, 360/32768°
Supply V	5 V ± 10%
Max. cable length	75 meters
A, B centered: $ V_1 - V_2 / 2 V_{pp}$	< 0.065
A&B relationship V _{App} / V _{Bpp}	0.8 ÷ 1.25
A&B phase shift	90° ± 10°

B. SIEMENS® Systems

The connection of absolute encoders to SIEMENS® systems is made through the SME 25 or SMC 20 modules of the Solution Line and Sinumerik One family.

ABSOLUTE signals

Transmission	SSI synchronous serial transfer via RS 485
Levels	EIA RS 485
Clock frequency	100 kHz - 500 kHz
Max. bit (n)	28
T	1 μs + 10 μs
t ₁	> 1 μs
t ₂	20 μs - 35 μs
SSI	Gray
Parity	Yes, odd

1 Vpp DIFFERENTIAL signals

Signals	A, /A, B, /B
V _{App}	1 V +20%, -40%
V _{Bpp}	1 V +20%, -40%
DC offset	2.5 V ± 0.5 V
Signal period	360/2048°, 360/16384°, 360/32768°
Supply V	5 V ± 10%
Max. cable length	100 meters
A, B centered: $ V_1 - V_2 / 2 V_{pp}$	< 0.065
A&B relationship V _{App} / V _{Bpp}	0.8 ÷ 1.25
A&B phase shift	90° ± 10°

C. Other systems

Please contact FAGOR for information on compatibility of the encoders with other systems.

2. Systems with BiSS® C interface

These systems use digital signals.

The absolute encoder with BiSS® C BP3 protocol is compatible with BiSS® C Unidirectional.

The absolute encoder is connected to the drive or system with BiSS® C BP3 or BiSS® C unidirectional interface. Please contact FAGOR for information on compatibility of the encoders with these systems.

H2A-D200i100 series



Model description:

- H2A: Absolute angular encoders with SSI protocol for FAGOR and others.
- H2AS: Absolute angular encoders with SSI protocol for SIEMENS® (Solution Line).
- H2AF: Absolute angular encoders with FANUC® (α and αi) protocol.
- H2AM: Absolute angular encoders with MITSUBISHI® CNC protocol.
- H2AP: Absolute angular encoders with PANASONIC® (Matsushita) protocol.
- H2AD: Absolute angular encoders with FeeDat® protocol for FAGOR and others.
- H2AD + EC-PA-DQ1-M: Absolute angular encoders with DRIVE-CLiQ® protocol, for SIEMENS® (Solution Line and Sinumerik One).
- H2ABC: Absolute angular encoders with BiSS® C protocol.

Characteristics

	H2A	H2AS	H2AF
Measurement	By means of graduated glass disk		
Accuracy	± 1 arc-second ± 2 arc-seconds		
Output signals	~ 1 Vpp	~ 1 Vpp	-
Resolution / Maximum number of positions per turn	27 bits (134 217 728 positions) 1 Vpp: 32 768 pulses/turn	27 bits (134 217 728 positions) 1 Vpp: 32 768 pulses/turn	α : 29 bits (536 870 912 positions) α : 27 bits (134 217 728 positions)
Maximum frequency	180 kHz for 1 Vpp signal	180 kHz for 1 Vpp signal	-
Maximum electrical speed	< 300 min ⁻¹	< 300 min ⁻¹	< 750 min ⁻¹
Natural frequency	> 500 Hz		
Supply	3.8 to 14 V DC; < 250 mA (at 5V without load)		
Maximum cable length	75 m (1)	100 m	30 m
Maximum mechanical speed	1000 min ⁻¹ non-mechanical fault exclusion		
Inertia	10 ⁻³ kgm ²		
Starting torque	< 0.5 Nm		
Vibration	100 m/s ² (55...2000 Hz) IEC 60068-2-6		
Shock	1000 m/s ² (6 ms) IEC 60068-2-27		
Operating temperature	0 °C...50 °C		
Storage temperature (in its packaging)	-20 °C...60 °C		
Weight	3.2 kg		
Protection	IP 64 DIN 40050 (standard) > IP 64 (DIN 40050) using pressurized air at 0.8 ±0.2 bar in angular encoders (3)		
Connection	With built-in connector		

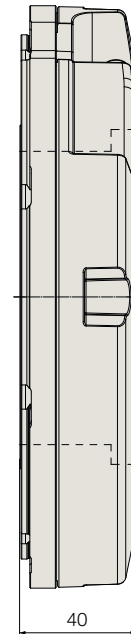
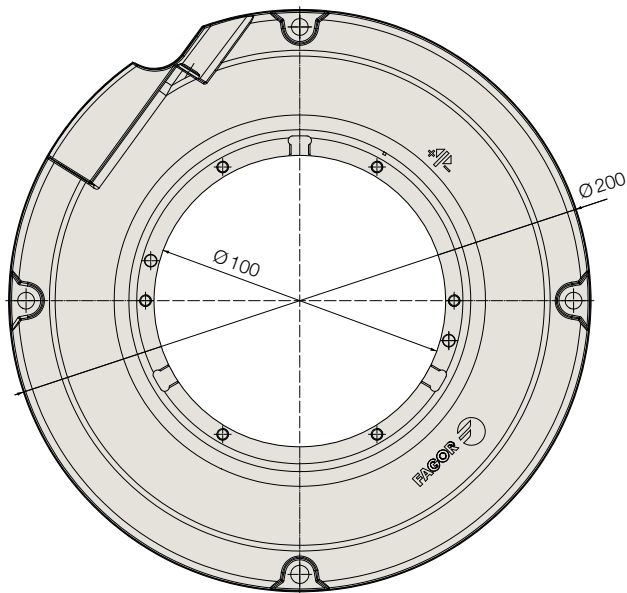

Dimensions in mm

Additional information can be found in the technical documentation and installation manual available on the website www.fagorautomation.com

Order identification

Example of Angular Encoder: **H2AF-29-D200i100-1**

H2	A	F	29	D200	i100	1
Type of shaft: • H2: Hollow shaft	Letter identifying the absolute encoder	Type of communications protocol: • Blank space: SSI protocol (FAGOR) • D: FeeDat® protocol (FAGOR) (1) • S: SSI SIEMENS® (SL) protocol • F: FANUC® (α and αi) protocol • M: MITSUBISHI® CNC protocol • P: PANASONIC® (Matsushita) protocol • BC: BiSS® C protocol	Absolute positions per turn: • 29 bits (536 870 912 positions) • 27 bits (134 217 728 positions)	Outside diameter: • D200: 200 mm	Inside diameter: • i100: 100 mm	Accuracy: • 2: ±2 arc-seconds • 1: ±1 arc-second

(1) Plus EC-PA-DQ1-M with DRIVE-CLiQ® protocol for SIEMENS® (Solution Line and Sinumerik One).

Notes: Not all protocol, positions per turn and accuracy combinations are possible. Please consult with Fagor Automation for a list models.

H2AM	H2AP	H2AD	H2AD + EC-PA-DQ1-M	H2ABC
By means of graduated glass disk				
±1 arc-second ±2 arc-seconds				
-	-	-	-	(2)
29 bits (536 870 912 positions)	29 bits (536 870 912 positions)	29 bits (536 870 912 positions)	29 bits (536 870 912 positions)	29 bits (536 870 912 positions)
-	-	-	-	-
< 750 min ⁻¹	< 750 min ⁻¹	< 750 min ⁻¹	< 750 min ⁻¹	< 750 min ⁻¹
> 500 Hz				
3.8 to 14 V DC; < 250 mA (at 5V without load)				
30 m	30 m	100 m	30 m	(1)
1000 min ⁻¹ non-mechanical fault exclusion				
10 ⁻³ kgm ²				
< 0.5 Nm				
100 m/s ² (55...2000 Hz) IEC 60068-2-6				
1000 m/s ² (6 ms) IEC 60068-2-27				
0 °C...50 °C				
-20 °C...60 °C				
3.2 kg				
IP 64 DIN 40050 (standard)				
> IP 64 (DIN 40050) using pressurized air at 0.8 ±0.2 bar in angular encoders (3)				
With built-in connector				

(1) Contact Fagor Automation for maximum cable length.

(2) Consult Fagor Automation for analog output signals.

(3) For more information consult the AI-1000 Filter Unit catalog.

H2A-D200 series

**Model description:**

- H2A: Absolute angular encoders with SSI protocol for FAGOR and others.
 H2AS: Absolute angular encoders with SSI protocol for SIEMENS® (Solution Line).
 H2AF: Absolute angular encoders with FANUC® (α and αi) protocol.
 H2AM: Absolute angular encoders with MITSUBISHI® CNC protocol.
 H2AP: Absolute angular encoders with PANASONIC® (Matsushita) protocol.
 H2AD: Absolute angular encoders with FeeDat® protocol for FAGOR and others.
 H2AD + EC-PA-DQ1-M: Absolute angular encoders with DRIVE-CLiQ® protocol, for SIEMENS® (Solution Line and Sinumerik One).
 H2ABC: Absolute angular encoders with BiSS® C protocol.

Characteristics

	H2A	H2AS	H2AF
Measurement	By means of graduated glass disk		
Accuracy	± 1 arc-second ± 2 arc-seconds		
Output signals	~ 1 Vpp	~ 1 Vpp	–
Resolution / Maximum number of positions per turn	27 bits (134 217 728 positions) 1 Vpp: 32 768 pulses/turn	27 bits (134 217 728 positions) 1 Vpp: 32 768 pulses/turn	αi : 29 bits (536 870 912 positions) α : 27 bits (134 217 728 positions)
Maximum frequency	180 kHz for 1 Vpp signal	180 kHz for 1 Vpp signal	–
Maximum electrical speed	< 300 min ⁻¹	< 300 min ⁻¹	< 750 min ⁻¹
Natural frequency	> 1000 Hz		
Supply	3.8 to 14 V DC; < 250 mA (at 5V without load)		
Maximum cable length	75 m (1)	100 m	30 m
Maximum mechanical speed	1000 min ⁻¹ non-mechanical fault exclusion		
Inertia	10 ⁻³ kgm ²		
Starting torque	< 0.5 Nm		
Vibration	100 m/s ² (55...2000 Hz) IEC 60068-2-6		
Shock	1000 m/s ² (6 ms) IEC 60068-2-27		
Operating temperature	0 °C...50 °C		
Storage temperature (in its packaging)	-20 °C...60 °C		
Weight	3.2 kg		
Protection	IP 64 DIN 40050 (standard) > IP 64 (DIN 40050) using pressurized air at 0.8 ± 0.2 bar in angular encoders (3)		
Connection	With built-in connector		

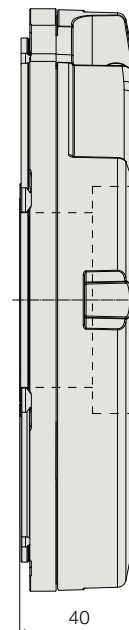
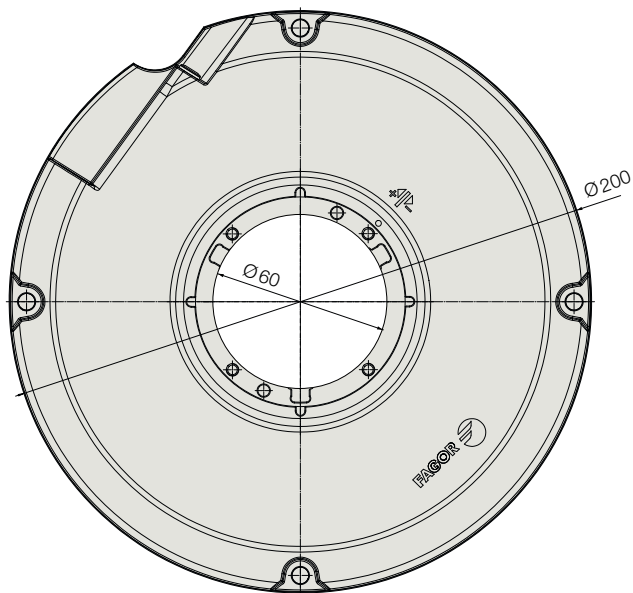

Dimensions in mm

Additional information can be found in the technical documentation and installation manual available on the website www.fagorautomation.com

Order identification

Example of Angular Encoder: **H2AF-29-D200-1**

H2	A	F	29	D200	1
Type of shaft: • H2: Hollow shaft	Letter identifying the absolute encoder	Type of communications protocol: • Blank space: SSI protocol (FAGOR) • D: FeeDat® protocol (FAGOR) (1) • S: SSI SIEMENS® (SL) protocol • F: FANUC® (α and αi) protocol • M: MITSUBISHI® CNC protocol • P: PANASONIC® (Matsushita) protocol • BC: BiSS® C protocol	Absolute positions per turn: • 29 bits (536 870 912 positions) • 27 bits (134 217 728 positions)	Outside diameter: • D200: 200 mm	Accuracy: • 2: ±2 arc-seconds • 1: ±1 arc-second

(1) Plus EC-PA-DQ1-M with DRIVE-CLiQ® protocol for SIEMENS® (Solution Line and Sinumerik One).

Notes: Not all protocol, positions per turn and accuracy combinations are possible. Please consult with Fagor Automation for a list models.

H2AM	H2AP	H2AD	H2AD + EC-PA-DQ1-M	H2ABC
By means of graduated glass disk				
±1 arc-second ±2 arc-seconds				
-	-	-	-	(2)
29 bits (536 870 912 positions)	29 bits (536 870 912 positions)	29 bits (536 870 912 positions)	29 bits (536 870 912 positions)	29 bits (536 870 912 positions)
-	-	-	-	-
< 750 min ⁻¹	< 750 min ⁻¹	< 750 min ⁻¹	< 750 min ⁻¹	< 750 min ⁻¹
> 1000 Hz				
3.8 to 14 V DC; < 250 mA (at 5V without load)				
30 m	30 m	100 m	30 m	(1)
1000 min ⁻¹ non-mechanical fault exclusion				
10 ⁻³ kgm ²				
< 0.5 Nm				
100 m/s ² (55...2000 Hz) IEC 60068-2-6				
1000 m/s ² (6 ms) IEC 60068-2-27				
0 °C...50 °C				
-20 °C...60 °C				
3.2 kg				
IP 64 DIN 40050 (standard)				
> IP 64 (DIN 40050) using pressurized air at 0.8 ±0.2 bar in angular encoders (3)				
With built-in connector				

(1) Contact Fagor Automation for maximum cable length.

(2) Consult Fagor Automation for analog output signals.

(3) For more information consult the AI-1000 Filter Unit catalog.

H2A-D90 series

**Model description:**

- H2A: Absolute angular encoders with SSI protocol for FAGOR and others.
 H2AS: Absolute angular encoders with SSI protocol for SIEMENS® (Solution Line).
 H2AF: Absolute angular encoders with FANUC® (α and αi) protocol.
 H2AM: Absolute angular encoders with MITSUBISHI® CNC protocol.
 H2AP: Absolute angular encoders with PANASONIC® (Matsushita) protocol.
 H2AD: Absolute angular encoders with FeeDat® protocol for FAGOR and others.
 H2AD + EC-PA-DQ1-M: Absolute angular encoders with DRIVE-CLiQ® protocol, for SIEMENS® (Solution Line and Sinumerik One).
 H2ABC: Absolute angular encoders with BiSS® C protocol.

Characteristics

	H2A	H2AS	H2AF
Measurement	By means of graduated glass disk		
Accuracy	± 2.5 arc-seconds ± 5 arc-seconds		± 2 arc-seconds ± 4 arc-seconds
Output signals	\sim 1 Vpp	\sim 1 Vpp	–
Resolution / Maximum number of positions per turn	23 bits (8 388 608 positions) 1 Vpp: 16 384 pulses/turn	23 bits (8 388 608 positions) 1 Vpp: 16 384 pulses/turn	αi : 28 bits (268 435 456 positions) α : 27 bits (134 217 728 positions)
Maximum frequency	400 kHz for 1 Vpp signal	400 kHz for 1 Vpp signal	–
Maximum electrical speed	< 1500 min ⁻¹		
Natural frequency	> 1000 Hz		
Supply	3.8 to 14 V DC; < 250 mA (at 5V without load)		
Maximum cable length	75 m (1)	100 m	30 m
Maximum mechanical speed	3000 min ⁻¹ non-mechanical fault exclusion		
Inertia	65 · 10 ⁻⁶ kgm ²		
Starting torque	< 0.08 Nm		
Vibration	100 m/s ² (55...2000 Hz) IEC 60068-2-6		
Shock	1000 m/s ² (6 ms) IEC 60068-2-27		
Operating temperature	0 °C...60 °C (5") o -20 °C...60 °C (5") non-mechanical fault exclusion; 0 °C...50 °C (2.5")		
Storage temperature (in its packaging)	-20 °C...60 °C		
Weight	1 kg		
Protection	IP 64 DIN 40050 (standard) > IP 64 (DIN 40050) using pressurized air at 0.8 ±0.2 bar in angular encoders (3)		
Connection	With built-in connector		

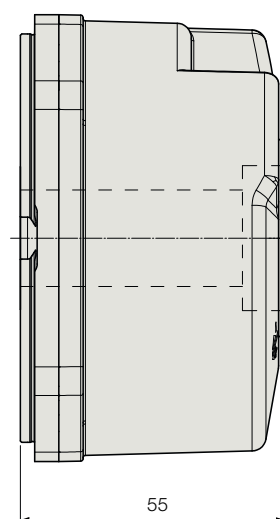
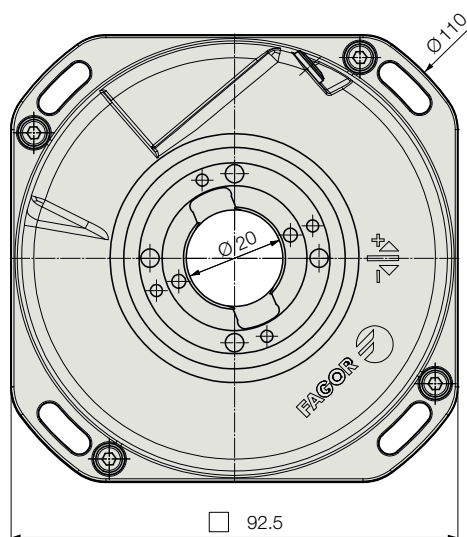

Additional information can be found in the technical documentation and installation manual available on the website www.fagorautomation.com

Order identification

Example of Angular Encoder: **H2AF-28-D90-2**

H2	A	F	28	D90	2
Type of shaft: • H2: Hollow shaft	Letter identifying the absolute encoder	Type of communications protocol: • Blank space: SSI protocol (FAGOR) • D: FeeDat® protocol (FAGOR) (1) • S: SSI SIEMENS® (SL) protocol • F: FANUC® (α and αi) protocol • M: MITSUBISHI® CNC protocol • P: PANASONIC® (Matsushita) protocol • BC: BiSS® C protocol	Absolute positions per turn: • 23 bits (8 388 608 positions) • 26 bits (67 108 864 positions) • 27 bits (134 217 728 positions) • 28 bits (268 435 456 positions)	Outside diameter: • D90: 90 mm	Accuracy: • Blank space: ±5 arc-seconds • 2: ±2.5 arc-seconds

(1) Plus EC-PA-DQ1-M with DRIVE-CLIQ® protocol for SIEMENS® (Solution Line and Sinumerik One).

Notes: Not all protocol, positions per turn and accuracy combinations are possible. Please consult with Fagor Automation for a list models.

H2AM	H2AP	H2AD	H2AD + EC-PA-DQ1-M	H2ABC
By means of graduated glass disk				
±2 arc-seconds ±4 arc-seconds				
-	-	-	-	(2)
28 bits (268 435 456 positions)	28 bits (268 435 456 positions)	28 bits (268 435 456 positions)	28 bits (268 435 456 positions)	26 bits (67 108 864 positions)
-	-	-	-	-
< 1500 min ⁻¹ > 1000 Hz				
3.8 to 14 V DC; < 250 mA (at 5V without load)				
30 m	30 m	100 m	30 m	(1)
3000 min ⁻¹ non-mechanical fault exclusion				
65 · 10 ⁻⁶ kgm ² < 0.08 Nm				
100 m/s ² (55...2000 Hz) IEC 60068-2-6 1000 m/s ² (6 ms) IEC 60068-2-27				
0 °C...60 °C (5") o -20 °C...60 °C (5") non-mechanical fault exclusion; 0 °C...50 °C (2.5") -20 °C...60 °C				
1 kg				
IP 64 DIN 40050 (standard) > IP 64 (DIN 40050) using pressurized air at 0.8 ±0.2 bar in angular encoders (3)				
With built-in connector				

(1) Contact Fagor Automation for maximum cable length.

(2) Consult Fagor Automation for analog output signals.

(3) For more information consult the AI-1000 Filter Unit catalog.



S2A-D170 series

**Model description:**

- S2A: Absolute angular encoders with SSI protocol for FAGOR and others.
- S2AS: Absolute angular encoders with SSI protocol for SIEMENS® (Solution Line).
- S2AF: Absolute angular encoders with FANUC® (α and αi) protocol.
- S2AM: Absolute angular encoders with MITSUBISHI® CNC protocol.
- S2AP: Absolute angular encoders with PANASONIC® (Matsushita) protocol.
- S2AD: Absolute angular encoders with FeeDat® protocol for FAGOR and others.
- S2AD + EC-PA-DQ1-M: Absolute angular encoders with DRIVE-CLiQ® protocol, for SIEMENS® (Solution Line and Sinumerik One).
- S2ABC: Absolute angular encoders with BiSS® C protocol.

Characteristics

	S2A	S2AS	S2AF
Measurement	By means of graduated glass disk		
Accuracy	± 2 arc-seconds		
Output signals	~ 1 Vpp	~ 1 Vpp	–
Resolution / Maximum number of positions per turn	23 bits (8 388 608 positions) 1 Vpp: 16 384 pulses/turn	23 bits (8 388 608 positions) 1 Vpp: 16 384 pulses/turn	αi : 28 bits (268 435 456 positions) α : 27 bits (134 217 728 positions)
Maximum frequency	400 kHz for 1 Vpp signal	400 kHz for 1 Vpp signal	–
Maximum electrical speed	< 1500 min ⁻¹		
Supply	3.8 to 14 V DC; < 250 mA (at 5V without load)		
Maximum cable length	75 m (1)	100 m	30 m
Maximum mechanical speed	3000 min ⁻¹		
Inertia	35 · 10 ⁻⁶ kgm ²		
Starting torque	< 0.01 Nm		
Load on the shaft	Axial: 1 kg Radial: 1 kg		
Vibration	100 m/s ² (55...2000 Hz) IEC 60068-2-6		
Shock	1000 m/s ² (6 ms) IEC 60068-2-27		
Operating temperature	0 °C...50 °C		
Storage temperature (in its packaging)	-20 °C...60 °C		
Weight	2.65 kg		
Protection	IP 64 DIN 40050 (standard) > IP 64 (DIN 40050) using pressurized air at 0.8 ± 0.2 bar in angular encoders (3)		
Connection	With built-in connector		

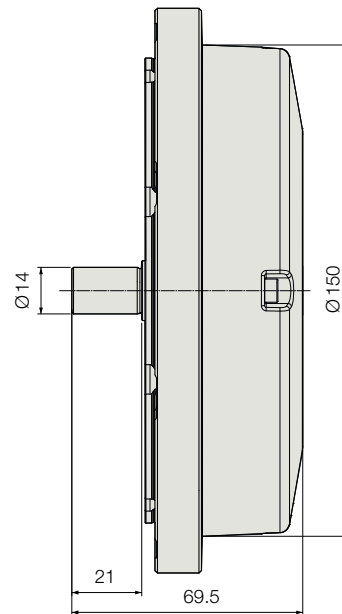
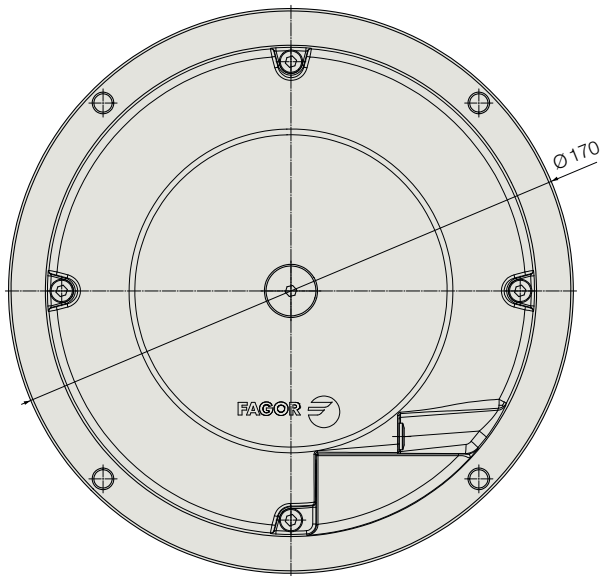

Additional information can be found in the technical documentation and installation manual available on the website www.fagorautomation.com

Order identification

Example of Angular Encoder: **S2AF-28-D170-2**

S2	A	F	28	D170	2
Type of shaft: • S2: Solid shaft	Letter identifying the absolute encoder	Type of communications protocol: • Blank space: SSI protocol (FAGOR) • D: FeeDat® protocol (FAGOR) (1) • S: SSI SIEMENS® (SL) protocol • F: FANUC® (α and αi) protocol • M: MITSUBISHI® CNC protocol • P: PANASONIC® (Matsushita) protocol • BC: BiSS® C protocol	Absolute positions per turn: • 23 bits (8 388 608 positions) • 26 bits (67 108 864 positions) • 27 bits (134 217 728 positions) • 28 bits (268 435 456 positions)	Outside diameter: • D170: 170 mm	Accuracy: • 2: ±2 arc-seconds

(1) Plus EC-PA-DQ1-M with DRIVE-CLiQ® protocol for SIEMENS® (Solution Line and Sinumerik One).

Notes: Not all protocol, positions per turn and accuracy combinations are possible. Please consult with Fagor Automation for a list models.

S2AM	S2AP	S2AD	S2AD + EC-PA-DQ1-M	S2ABC
By means of graduated glass disk				
±2 arc-seconds				
-	-	-	-	(2)
28 bits (268 435 456 positions)	28 bits (268 435 456 positions)	28 bits (268 435 456 positions)	28 bits (268 435 456 positions)	26 bits (67 108 864 positions)
-	-	-	-	-
< 1500 min ⁻¹				
3.8 to 14 V DC; < 250 mA (at 5V without load)				
30 m	30 m	100 m	30 m	(1)
3000 min ⁻¹				
35 · 10 ⁻⁶ kgm ²				
< 0.01 Nm				
Axial: 1 kg Radial: 1 kg				
100 m/s ² (55...2000 Hz) IEC 60068-2-6				
1000 m/s ² (6 ms) IEC 60068-2-27				
0 °C...50 °C				
-20 °C...60 °C				
2.65 kg				
IP 64 DIN 40050 (standard)				
> IP 64 (DIN 40050) using pressurized air at 0.8 ±0.2 bar in angular encoders (3)				
With built-in connector				

(1) Contact Fagor Automation for maximum cable length.

(2) Consult Fagor Automation for analog output signals.

(3) For more information consult the AI-1000 Filter Unit catalog.

S2A-D90 series

**Model description:**

S2A: Absolute angular encoders with SSI protocol for FAGOR and others.

S2AS: Absolute angular encoders with SSI protocol for SIEMENS® (Solution Line).

S2AF: Absolute angular encoders with FANUC® (α and αi) protocol.

S2AM: Absolute angular encoders with MITSUBISHI® CNC.

S2AP: Absolute angular encoders with PANASONIC® (Matsushita) protocol.

S2AD: Absolute angular encoders with FeeDat® protocol for FAGOR and others.

S2AD + EC-PA-DQ1-M: Absolute angular encoders with DRIVE-CLiQ® protocol, for SIEMENS® (Solution Line and Sinumerik One).

S2ABC: Absolute angular encoders with BiSS® C protocol.

Characteristics

	S2A	S2AS	S2AF
Measurement	By means of graduated glass disk		
Accuracy	± 2.5 arc-seconds ± 5 arc-seconds		± 2 arc-seconds ± 4 arc-seconds
Output signals	~ 1 Vpp	~ 1 Vpp	–
Resolution / Maximum number of positions per turn	23 bits (8 388 608 positions) 1 Vpp: 16 384 pulses/turn	23 bits (8 388 608 positions) 1 Vpp: 16 384 pulses/turn	αi : 28 bits (268 435 456 positions) α : 27 bits (134 217 728 positions)
Maximum frequency	400 kHz for 1 Vpp signal	400 kHz for 1 Vpp signal	–
Maximum electrical speed	< 1500 min ⁻¹		
Supply	3.8 to 14 V DC; < 250 mA (at 5V without load)		
Maximum cable length	75 m (1)	100 m	30 m
Maximum mechanical speed	10000 min ⁻¹		
Inertia	25 · 10 ⁻⁶ kgm ²		
Starting torque	< 0.01 Nm		
Load on the shaft	Axial: 1 kg Radial: 1 kg		
Vibration	100 m/s ² (55...2000 Hz) IEC 60068-2-6		
Shock	1000 m/s ² (6 ms) IEC 60068-2-27		
Operating temperature	-20 °C...60 °C (5"); 0 °C...50 °C (2.5")		
Storage temperature (in its packaging)	-20 °C...60 °C		
Weight	0.8 kg		
Protection	IP 64 DIN 40050 (standard) > IP 64 (DIN 40050) using pressurized air at 0.8 ± 0.2 bar in angular encoders (3)		
Connection	With built-in connector		

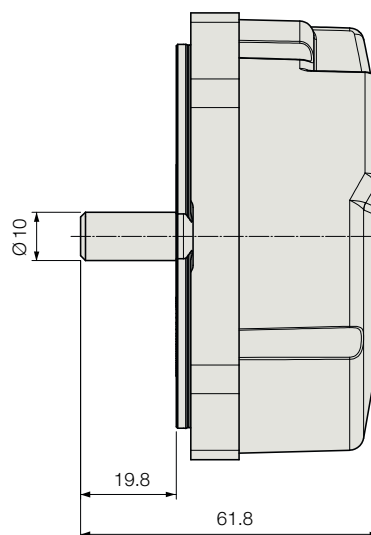
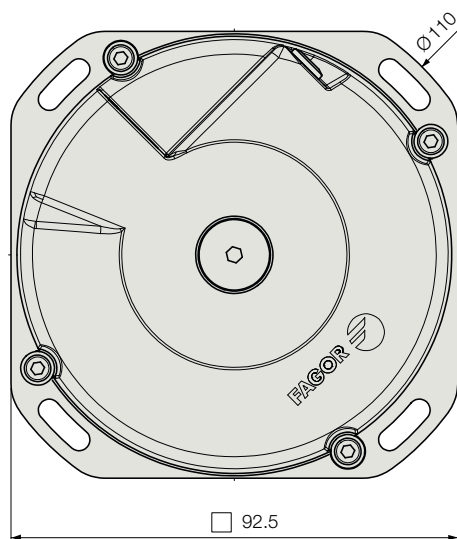

Additional information can be found in the technical documentation and installation manual available on the website www.fagorautomation.com

Order identification

Example of Angular Encoder: **S2AF-28-D90-2**

S2	A	F	28	D90	2
Type of shaft: • S2: Solid shaft	Letter identifying the absolute encoder	Type of communications protocol: • Blank space: SSI protocol (FAGOR) • D: FeeDat® protocol (FAGOR) (1) • S: SSI SIEMENS® (SL) protocol • F: FANUC® (α and αi) protocol • M: MITSUBISHI® CNC protocol • P: PANASONIC® (Matsushita) protocol • BC: BISS® C protocol	Absolute positions per turn: • 23 bits (8 388 608 positions) • 26 bits (67 108 864 positions) • 27 bits (134 217 728 positions) • 28 bits (268 435 456 positions)	Outside diameter: • D90: 90 mm	Accuracy: • Blank space: ± 5 arc-seconds • 2: ± 2.5 arc-seconds

(1) Plus EC-PA-DQ1-M with DRIVE-CLiQ® protocol for SIEMENS® (Solution Line and Sinumerik One).

Notes: Not all protocol, positions per turn and accuracy combinations are possible. Please consult with Fagor Automation for a list models. For a different number of positions per turn, please contact Fagor Automation.

S2AM	S2AP	S2AD	S2AD + EC-PA-DQ1-M	S2ABC
By means of graduated glass disk				
± 2 arc-seconds				
± 4 arc-seconds				
-	-	-	-	(2)
28 bits (268 435 456 positions)	28 bits (268 435 456 positions)	28 bits (268 435 456 positions)	28 bits (268 435 456 positions)	26 bits (67 108 864 positions)
-	-	-	-	-
< 1500 min ⁻¹				
3.8 to 14 V DC; < 250 mA (at 5V without load)				
30 m	30 m	100 m	30 m	(1)
10000 min ⁻¹				
25 · 10 ⁻⁶ kgm ²				
< 0.01 Nm				
Axial: 1 kg				
Radial: 1 kg				
100 m/s ² (55...2000 Hz) IEC 60068-2-6				
1000 m/s ² (6 ms) IEC 60068-2-27				
-20°C...60°C (5"); 0°C...50°C (2.5")				
-20°C...60°C				
0.8 kg				
IP 64 DIN 40050 (standard)				
> IP 64 (DIN 40050) using pressurized air at 0.8 ± 0.2 bar in angular encoders (3)				
With built-in connector				

(1) Contact Fagor Automation for maximum cable length.

(2) Consult Fagor Automation for analog output signals.

(3) For more information consult the AI-1000 Filter Unit catalog.



H2A-D87 series



Model description:

- H2A: Absolute angular encoders with SSI protocol for FAGOR and others.
- H2AS: Absolute angular encoders with SSI protocol for SIEMENS® (Solution Line).
- H2AF: Absolute angular encoders with FANUC® (α and αi) protocol.
- H2AM: Absolute angular encoders with MITSUBISHI® CNC.
- H2AP: Absolute angular encoders with PANASONIC® (Matsushita) protocol.
- H2AD: Absolute angular encoders with FeeDat® protocol for FAGOR and others.
- H2AD + XC-C8-PA-DQ-M: Absolute angular encoders with DRIVE-CLiQ® protocol, for SIEMENS® (Solution Line and Sinumerik One).
- H2ABC: Absolute angular encoders with BiSS® C protocol.

Order identification

Example of Angular Encoder: **H2AD-23-D87i50-F-1C9D**

H2	A	D	23	D87	i50	F	
Type of shaft: • H2: Hollow shaft	Letter identifying the absolute encoder	Type of communications protocol: • Blank space: SSI protocol (FAGOR) • D: FeeDat® protocol (FAGOR) (1) • S: SSI SIEMENS® (SL) protocol • F: FANUC® (α and αi) protocol • M: MITSUBISHI® CNC protocol (2) • P: PANASONIC® (Matsushita) protocol • BC: BiSS® C protocol	Absolute positions per turn: • 23 bits (8 388 608 positions) • 25 bits (33 554 432 positions) • 26 bits (67 108 864 positions)	Outside diameter: • D87: 87 mm	Inside diameter: • i20: 20 mm • i50: 50 mm	Coupling type: • C: External coupling (3) • F: Mounting flange	Accuracy: • Blank space: ± 10 arc-seconds (4) • ± 20 arc-seconds (5)

(1) Plus XC-C8-PA-DQ-M with DRIVE-CLiQ® protocol for SIEMENS® (Solution Line and Sinumerik One).

(2) Only Full Duplex type.

(3) Only 50 mm internal diameter.

(4) With F type coupling.

(5) With external coupling.

(6) Mitsubishi® models with ferrite. Description C9D-F.

Notes: Not all protocol, positions per turn and accuracy combinations are possible. Please consult with Fagor Automation for a list models. For a different number of positions per turn, please contact Fagor Automation.

Characteristics

	H2A	H2AS	H2AF
Measurement	By means of graduated glass disk		
Coupling	External coupling or mounting flange		
Shaft	Hollow through shaft: • Diameter 20 mm (flange coupling only) • Diameter 50 mm		
Accuracy	External coupling: ± 20 arc-seconds; Mounting flange: ± 10 arc-seconds		
Output signals	~ 1 Vpp	~ 1 Vpp	-
Resolution / Maximum number of positions per turn	23 bits (8 388 608 positions) 1 Vpp: 2 048 pulses/turn	23 bits (8 388 608 positions) 1 Vpp: 2 048 pulses/turn	α : 25 bits (33 554 432 positions) α : 23 bits (8 388 608 positions)
Maximum frequency	100 kHz for 1 Vpp signal	100 kHz for 1 Vpp signal	-
Maximum electrical speed	3000 min ⁻¹		
Natural frequency	≥ 1000 Hz		
Supply	3.8 to 14 V DC; < 100 mA (at 5V without load)		
Maximum cable length	75 m (1)	100 m	30 m
Maximum mechanical speed	3000 min ⁻¹		
Inertia	D _{int} = 20 mm: 0.125 10-3 kgm ² D _{int} = 50 mm: 0.215 10-3 kgm ²		
Starting torque	D _{int} = 20 mm: ≤ 0.15 Nm; D _{int} = 50 mm: ≤ 0.20 Nm		
Vibration	100 m/s ² (55...2000 Hz) IEC 60068-2-6		
Shock	Flange coupling: 200 m/s ² (6 ms) IEC 60068-2-27; External coupling: 1000 m/s ² (6 ms) IEC 60068-2-27		
Operating temperature	Flexing cable: -10 °C to 60 °C Fixed cable: -20 °C to 60 °C		
Storage temperature (in its packaging)	-20 °C...60 °C		
Weight	D _{int} = 20 mm: 0.8 kg; D _{int} = 50 mm: 0.7 kg		
Protection	IP 64 DIN 40050		
Connection	With cable included		

External coupling $D_{int} = 50$ mm

Dimensions in mm

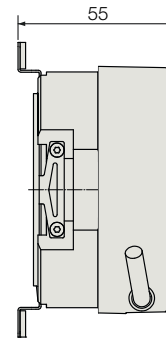
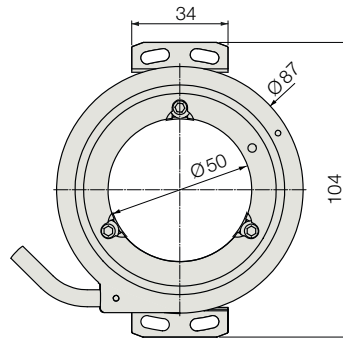

Mounting flange $D_{int} = 20$ mm

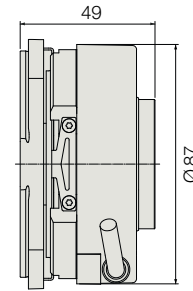
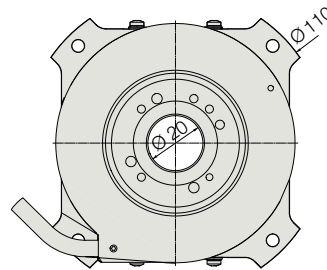

Mounting flange $D_{int} = 50$ mm

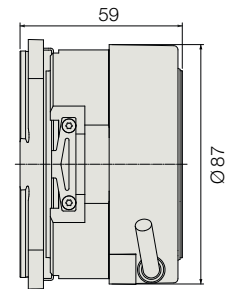
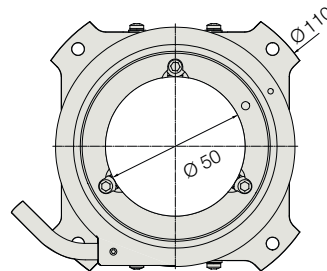

1	C9D
Cable length: 1: 1 meter 3: 3 meters	Terminal connector: • FN: FANUC® • MB: MITSUBISHI® • PN5: PANASONIC® • C9: M23 17 M pin connector digital connection + 1 Vpp • C9D: M23 17 M pin connector digital connection only (6)

Additional information can be found in the technical documentation and installation manual available on the website www.fagorautomation.com

H2AM	H2AP	H2AD	H2AD + XC-C8-PA-DQ-M	H2ABC
By means of graduated glass disk				
External coupling or mounting flange				
Hollow through shaft: • Diameter 20 mm (flange coupling only) • Diameter 50 mm				
External coupling: ± 20 arc-seconds; Mounting flange: ± 10 arc-seconds				
–	–	–	–	(2)
25 bits (33 554 432 positions)	23 bits (8 388 608 positions)	23 bits (8 388 608 positions)	23 bits (8 388 608 positions)	26 bits (67 108 864 positions)
–	–	–	–	–
$< 3000 \text{ min}^{-1}$				
$\geq 1000 \text{ Hz}$				
3.8 to 14 V DC; $< 100 \text{ mA}$ (at 5V without load)				
30 m	30 m	100 m	30 m	(1)
3000 min^{-1}				
$D_{int} = 20 \text{ mm}$: $0.125 \cdot 10^{-3} \text{ kgm}^2$ $D_{int} = 50 \text{ mm}$: $0.215 \cdot 10^{-3} \text{ kgm}^2$				
$D_{int} = 20 \text{ mm}$: $\leq 0.15 \text{ Nm}$; $D_{int} = 50 \text{ mm}$: $\leq 0.20 \text{ Nm}$				
100 m/s^2 (55...2000 Hz) IEC 60068-2-6				
Flange coupling: 200 m/s^2 (6 ms) IEC 60068-2-27; External coupling: 1000 m/s^2 (6 ms) IEC 60068-2-27				
Flexing cable: $-10 \text{ }^\circ\text{C}$ to $60 \text{ }^\circ\text{C}$ Fixed cable: $-20 \text{ }^\circ\text{C}$ to $60 \text{ }^\circ\text{C}$ $-20 \text{ }^\circ\text{C}$... $60 \text{ }^\circ\text{C}$				
$D_{int} = 20 \text{ mm}$: 0.8 kg; $D_{int} = 50 \text{ mm}$: 0.7 kg				
IP 64 DIN 40050				
With cable included				

(1) Contact Fagor Automation for maximum cable length.
(2) Consult Fagor Automation for analog output signals.

direct connection cables

FAGOR FeeDat[®] and SSI connections

UP TO 9 METERS (except D87 family with cable and terminal connector included)

For direct connection to FAGOR AXD

EC-...B-D

Lengths: 1, 3, 6 and 9 meters

SUB D 15 HD connector (male Pin )

Pin	Signal	Color
1	A	Green
2	/A	Yellow
3	B	Blue
4	/B	Red
5	Data	Grey
6	/Data	Pink
7	Clock	Black
8	/Clock	Purple
9	+5 V	Brown
10	+5 V sensor	Light green
11	0 V	White
12	0 V sensor	Orange
15	Ground	Internal shield
Housing	Ground	External shield

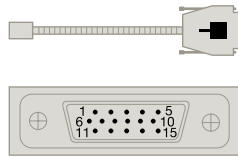

For direct connection to FAGOR QUERCUS

EC-...B-DA

Lengths: 1, 3, 6 and 9 meters

SUB D 15 HD connector (male Pin )

Pin	Signal	Color
1	A	Green
2	/A	Yellow
3	B	Blue
4	/B	Red
5	Data	Grey
6	/Data	Pink
7	Clock	Black
8	/Clock	Purple
9	+5 V	Brown
10	+5 V sensor	Light green
11	0 V	White
12	0 V sensor	Orange
Housing	Ground	Shields

For direct connection to SIEMENS[®] SME25 or for extension cable

EC-...B-C9

Lengths: 1, 3, 6 and 9 meters
(only 1 or 3 meters with extension cable)

M23 17 connector (male Pin )

Pin	Signal	Color
15	A	Green
16	/A	Yellow
12	B	Blue
13	/B	Red
14	Data	Grey
17	/Data	Pink
8	Clock	Black
9	/Clock	Purple
7	+5 V	Brown
1	+5 V sensor	Light green
10	0 V	White
4	0 V sensor	Orange
11	Ground	Internal shield
Housing	Ground	External shield

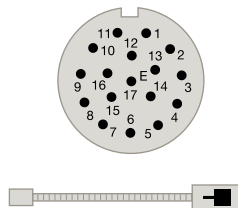

For direct connection to SIEMENS[®] SMC20

EC-...B-S1

Lengths: 1, 3, 6 and 9 meters

SUB D 25 connector (female Pin )

Pin	Signal	Color
3	A	Green
4	/A	Yellow
6	B	Blue
7	/B	Red
15	Data	Grey
23	/Data	Pink
10	Clock	Black
12	/Clock	Purple
1	+5 V	Brown
14	+5 V sensor	Light green
2	0 V	White
16	0 V sensor	Orange
5	Ground	Internal shield
Housing	Ground	External shield

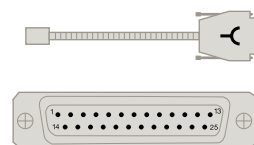

FROM 9 METERS ON

For connection to FAGOR AXD: EC-...B-C9 cable + XC-C8-...F-D extension cable

For connection to FAGOR QUERCUS: EC-...B-C9 cable + XC-C8-...F-DA extension cable

For connection to SIEMENS® SMC20: EC-...B-C9 cable + XC-C8-...F-S1 extension cable

For connection to SIEMENS® SME25: EC-...B-C9 cable + XC-C8-...F-C9 extension cable

D87 models:

H2A-D87-C9. For connection to FAGOR AXD: XC-C8-...F-D extension cable

H2AD-D87-C9. For connection to FAGOR QUERCUS: XC-C8-...F-DA extension cable

H2AS-D87-C9. For connection to SIEMENS® SMC20: XC-C8-...F-S1 extension cable



SME25: XC-C8-...F-C9 extension cable

XC-C8-...F-D extension cable

Lengths: 5, 10, 15, 20 and 25 meters

M23 17 connector (female Pin )

SUB D 15 HD connector (male Pin )

 Pin	 Pin	Signal	Color
15	1	A	Green/Black
16	2	/A	Yellow/Black
12	3	B	Blue/Black
13	4	/B	Red/Black
14	5	Data	Grey
17	6	/Data	Pink
8	7	Clock	Purple
9	8	/Clock	Yellow
7	9	+5 V	Brown/Green
1	10	+5 V sensor	Blue
10	11	0 V	White/Green
4	12	0 V sensor	White
11	15	Ground	Internal shield
Housing	Housing	Ground	External shield

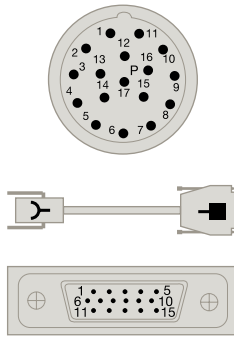



XC-C8-...F-DA extension cable

Lengths: 5, 10, 15, 20 and 25 meters

M23 17 connector (female Pin )

SUB D 15 HD connector (male Pin )



 Pin	 Pin	Signal	Color
15	1	A	Green/Black
16	2	/A	Yellow/Black
12	3	B	Blue/Black
13	4	/B	Red/Black
14	5	Data	Grey
17	6	/Data	Pink
8	7	Clock	Purple
9	8	/Clock	Yellow
7	9	+5 V	Brown/Green
1	10	+5 V sensor	Blue
10	11	0 V	White/Green
4	12	0 V sensor	White
Housing	Housing	Ground	Shields

XC-C8-...F-S1 extension cable

Lengths: 5, 10, 15, 20 and 25 meters

M23 17 connector (female Pin )

SUB D25 connector (female Pin )

 Pin	 Pin	Signal	Color
15	3	A	Green/Black
16	4	/A	Yellow/Black
12	6	B	Blue/Black
13	7	/B	Red/Black
14	15	Data	Grey
17	23	/Data	Pink
8	10	Clock	Purple
9	12	/Clock	Yellow
7	1	+5 V	Brown/Green
1	14	+5 V sensor	Blue
10	2	0 V	White/Green
4	16	0 V sensor	White
11	5	Ground	Internal shield
Housing	Housing	Ground	External shield

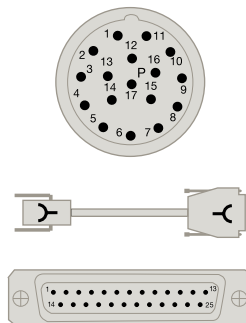

XC-C8-...F-C9 extension cable

Lengths: 5, 10, 15, 20 and 25 meters

M23 17 connector (female Pin )

M23 17 connector (male Pin )

 Pin	 Pin	Signal	Color
15	15	A	Green/Black
16	16	/A	Yellow/Black
12	12	B	Blue/Black
13	13	/B	Red/Black
14	14	Data	Grey
17	17	/Data	Pink
8	8	Clock	Purple
9	9	/Clock	Yellow
7	7	+5 V	Brown/Green
1	1	+5 V sensor	Blue
10	10	0 V	White/Green
4	4	0 V sensor	White
11	11	Ground	Internal shield
Housing	Housing	Ground	External shield

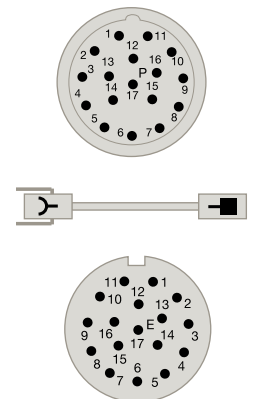

direct connection cables

Connection to other CNC's

UP TO 9 METERS (except D87 family with cable and terminal connector included)

For direct connection to FANUC®

EC-...PA-FN

Lengths: 1, 3, 6 and 9 meters

HONDA / HIROSE connector (female Pin )

Pin	Signal	Color
1	Data	Green
2	/Data	Yellow
5	Request	Blue
6	/Request	Red
9	+5 V	Brown
18-20	+5 V sensor	Grey
12	0 V	White
14	0 V sensor	Pink
16	Ground	Shield

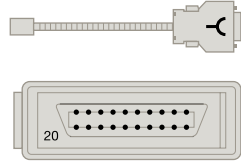

For direct connection to MITSUBISHI®

EC-...AM-MB

Lengths: 1, 3, 6 and 9 meters

10-pin MOLEX/3M RECTANGULAR connector (female Pin )

Pin	Signal	Color
7	SD (MD)	Green
8	/SD (MD)	Yellow
3	RQ (MR)	Grey
4	/RQ (MR)	Pink
1	+5 V	Brown + purple
2	0 V	White + black + blue
Housing	Ground	Shield

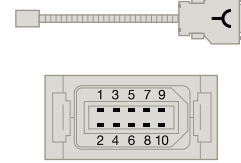

For direct connection to PANASONIC® MINAS A5

EC-...PA-PN5

Lengths: 1, 3, 6 and 9 meters

PANASONIC 10 pin connector (female Pin )

Pin	Signal	Color
3	Data	Green
4	/Data	Yellow
1	+5 V	Brown + grey
2	0 V	White + pink
Housing	Ground	Shield

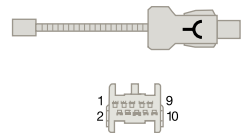

For connection with extension cable (M12 H-RJ45) to SIEMENS® Sinamics/Sinumerik

EC-...PA-DQ1-M

Lengths: 1, 3, 6 and 9 meters

Pin	Signal
3	RXP
4	RXN
6	TXN
7	TXP
1	Vcc (24 V)
5	0 V



H2AD-D87-C9D (1 or 3 meters cable included):

For connection with extension cable (M12 H-RJ45) to SIEMENS® Sinamics/Sinumerik®

XC-C8-...PA-DQ-M

Lengths: 1, 3 and 6 meters

Pin	Signal
3	RXP
4	RXN
6	TXN
7	TXP
1	Vcc (24 V)
5	0 V



FROM 9 METERS ON

For connection to FANUC®:

EC-... B-C9 cable + XC-C8-... -FN extension cable

EC-... PA-M1-N cable + XC-M2-...D- FN extension cable

For connection to MITSUBISHI®: EC-... B-C9-F cable + XC-C8-... -MB extension cable

For connection to PANASONIC® MINAS A5: EC-...B-C9 cable + XC-C8-...A-PN5 extension cable

For connection to SIEMENS®:

RJ 45 connector with IP 20: EC-...PA-DQ1-M cable + XC- M2-...S-RJ2 extension cable

RJ 45 connector with IP 67: EC-...PA-DQ1-M cable + XC- M2-...S-RJ6 extension cable

D87 models:

H2AF-D87-C9D. For connection to FANUC®: XC-C8-... -FN extension cable

H2AM-D87-C9D-F. For connection to MITSUBISHI®: XC-C8-... -MB extension cable

H2AP-D87-C9D. For connection to PANASONIC® MINAS A5: XC-C8-...A-PN5 extension cable

H2AD-D87-C9D: For connection to SIEMENS®:

RJ 45 connector with IP 20: XC-C8-...PA-DQ-M cable + XC- M2-...S-RJ2 extension cable

RJ 45 connector with IP 67: XC-C8-...PA-DQ-M cable + XC- M2-...S-RJ6 extension cable

EC-...B-C9

Lengths: 1 and 3 meters

(consult Fagor Automation for others)

M23 17 connector (male Pin )

Pin	Signal	Color
14	Data	Grey
17	/Data	Pink
8	Request	Black
9	/Request	Purple
7	+5 V	Brown
1	+5 V sensor	Light green
10	0 V	White
4	0 V sensor	Orange
Housing	Ground	Shield

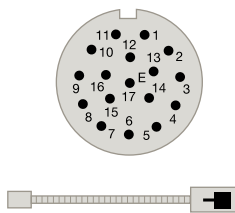

EC-...B-C9-F

Lengths: 1 and 3 m with Ferrite

(consult Fagor Automation for others)

M23 17 connector (male Pin )

Pin	Signal	Color
14	Data	Grey
17	/Data	Pink
8	Request	Black
9	/Request	Purple
7	+5 V	Brown
1	+5 V sensor	Light green
10	0 V	White
4	0 V sensor	Orange
Housing	Ground	Shield

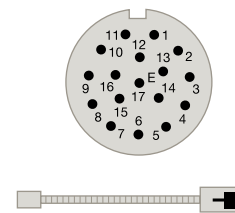

EC-...PA-M1-N

Lengths: 1 and 3 meters

(consult Fagor Automation for others)

M12 8 pin connector (male Pin )

Pin	Signal	Color
8 & 2	+5V	Brown + Grey
5 & 1	0 V	White + Pink
3	Data	Green
4	/Data	Yellow
7	Clock (REQ)	Blue
6	/Clock (/REQ)	Red
Housing	Ground	Shield

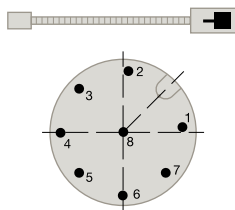

direct connection cables

Connection to other CNC's

FROM 9 METERS ON

XC-C8...-FN extension cable

Lengths: 5, 10, 15, 20 and 25 meters

M23 17 connector (female Pin ⤴)

HONDA / HIROSE connector (female Pin ⤵)

Pin	Pin	Signal	Color
14	1	Data	Grey
17	2	/Data	Pink
8	5	Request	Purple
9	6	/Request	Yellow
7	9	+5 V	Brown/Green
1	18-20	+5 V sensor	Blue
10	12	0 V	White/Green
4	14	0 V sensor	White
Housing	16	Ground	Shield

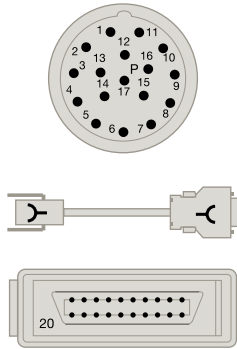

XC-C8...-MB extension cable

Lengths: 5, 10, 15, 20 and 25 meters

M23 17 connector (female Pin ⤴)

10-pin MOLEX/3M RECTANGULAR connector (female Pin ⤵)

Pin	Pin	Signal	Color
8	7	SD (MD)	Purple
9	8	/SD (MD)	Yellow
14	3	RQ (MR)	Grey
17	4	/RQ (MR)	Pink
7	1	+5 V	Brown/Green
1	1	+5 V sensor	Blue
10	2	GND	White/Green
4	2	0 V sensor	White
12	2	SEL	Black
Housing	Housing	Ground	Shield

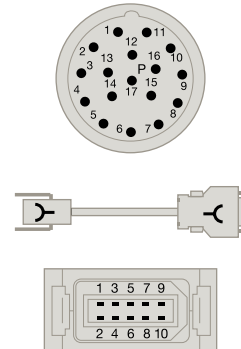

XC-C8...A-PN5 extension cable

Lengths: 5, 10, 15, 20 and 25 meters

M23 17 connector (female Pin ⤴)

PANASONIC 10 pin connector (female Pin ⤵)

Pin	Pin	Signal	Color
14	3	Data	Grey
17	4	/Data	Pink
7	1	+5 V	Brown+Black
1	1	+5 V sensor	Green +Yellow
10	2	GND	White+Purple
4	2	GND sensor	Blue+Red
Housing	Housing	Ground	Shield

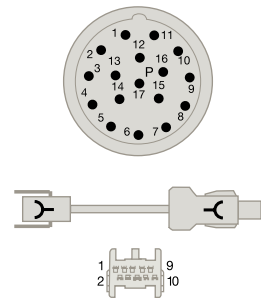

XC-M2...D-FN extension cable

Lengths: 5, 10, 15, 20 and 25 meters

M12 8 pin connector (female Pin ⤴)

HONDA / HIROSE connector (female Pin ⤵)

Pin	Pin	Signal	Color
2	18, 20	+5V sensor	White
1	14	0 V sensor	Blue
8	9	+5V	White-Green
7	5	REQ	Purple
6	6	/REQ	Pink
5	12	0 V	Brown-Green
3	1	Data	Yellow
4	2	/Data	Grey
Housing	16	Ground	Shield

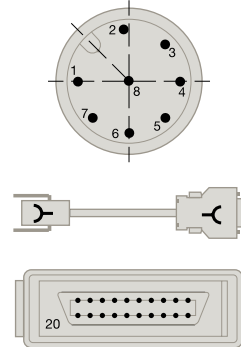

XC-M2...S-RJ2 extension cable

Lengths: 5, 10, 15, 20 and 25 meters

M12 8 pin connector (female Pin ⤴)

RJ45 (IP 20) connector

Pin	Pin	Signal	Color
3	1	RXP	Pink
4	2	RXN	Blue
7	3	TXP	Green
6	6	TXN	Yellow
1	a	Vcc (24V)	Red
5	b	0 V	Black
Housing	Housing	Ground	Shield

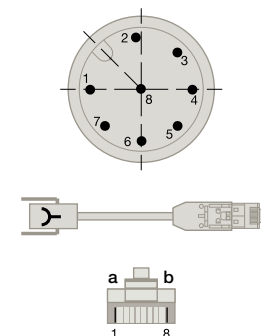

XC-M2...S-RJ6 extension cable

Lengths: 5, 10, 15, 20 and 25 meters

M12 8 pin connector (female Pin ⤴)

RJ45 (IP 67) connector

Pin	Pin	Signal	Color
3	1	RXP	Pink
4	2	RXN	Blue
7	3	TXP	Green
6	6	TXN	Yellow
1	a	Vcc (24V)	Red
5	b	0 V	Black
Housing	Housing	Ground	Shield

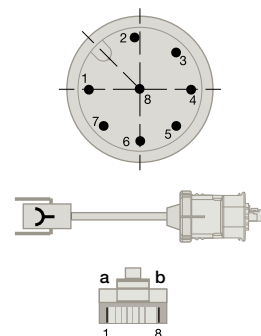



Range

Analyze the application to make sure that the proper encoder will be selected for the machine.

To do this, bear in mind the following considerations:

Installation: Consider the physical length of the installation and the space available for it. It is essential to determine its type of shaft: Hollow or solid.

Accuracy: Each angular encoder comes with a graph showing its accuracy along its measuring length.

Signal: La selección de la señal considera las siguientes variables: Resolución, longitud de cable y compatibilidad.

Resolution: The resolution of the control of machine-tools depends on the angular encoder.



Cable length: The length of the cable depends on the type of signal.

Speed: The speed requirements for the application must be analyzed before choosing the linear encoder.

Shock and Vibration: Fagor angular encoders withstand vibrations of up to 100 m/s² and shocks of up to 1000 m/s².

Alarm signal: Models H2-D200, H2-D90, S2-D170 and S2-D90 offer the alarm signal AL.

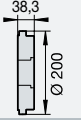
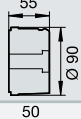
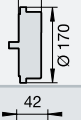
Angular

Series	Section
H2-D200	
H2-D90	
S2-D170	
S2-D90	

Rotary

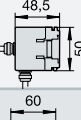
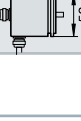
Series	Section
H	
S	

Tecnología

The incremental encoders provide direct measure of machine position without using any intermediate device.

The errors originated in the mechanics of the machine are avoided because the encoder is mounted on the machine axis and sends the real movement data to the controller; some of the potential sources of error, such as those caused by the thermal behavior of the machine, may be minimized using encoders.

Measuring Methods

Fagor Automation uses the graduated glass measuring method in its incremental angular and rotary encoders

The light from the LED goes through an engraved glass and a reticule before reaching the receiving photo diodes. The measurement is made based on the pitch determined by the number of pulses/turn.

Types of incremental encoders

- **Angular encoder:** Used as an angular movement sensor on machines/devices requiring high resolution and accuracy. Fagor Angular encoders offer from 18000 to 360000 pulses/turn and accuracy levels of ±5", ±2.5", ±2" and ±1" depending on the model.
- **Rotary encoder:** Used as a measuring sensor for rotary movements, angular speeds and also linear movement when connected to a mechanical device like ball screw. They are also used on various types of machine tools and robotic applications.

In them, the graduated disk of the measuring system is attached directly to the shaft. They have bearings and couplings that serve as guide and adjustment.

Couplings, besides minimizing the static and dynamic deviations, compensate for axial movements of the shaft providing easier mounting, smaller size and the possibility of hollow shafts.

Type of shaft	Accuracy	Signals	Model	Page
Hollow shaft	$\pm 1''$ $\pm 2''$	~ 1 Vpp	H2P-D200 / H2OP-D200	36
	$\pm 2''$	\square TTL	H2-D200 / H2O-D200	
Hollow shaft	$\pm 2.5''$ $\pm 5''$	~ 1 Vpp	H2P-D90 / H2OP-D90	38
		\square TTL	H2-D90 / H2O-D90	
Solid shaft	$\pm 2''$	~ 1 Vpp	S2P-D170 / S2OP-D170	40
		\square TTL	S2-D170 / S2O-D170	
Solid shaft	$\pm 2.5''$ $\pm 5''$	~ 1 Vpp	S2P-D90 / S2OP-D90	42
		\square TTL	S2-D90 / S2O-D90	

Type of shaft	Accuracy	Signals	Model	Page
Hollow shaft	$\pm 1/10$ of the pitch	~ 1 Vpp	HP	44
		\square TTL	H / HA	
Solid shaft	$\pm 1/10$ of the pitch	~ 1 Vpp	SP	44
		\square TTL	S	

Graduated glass disk

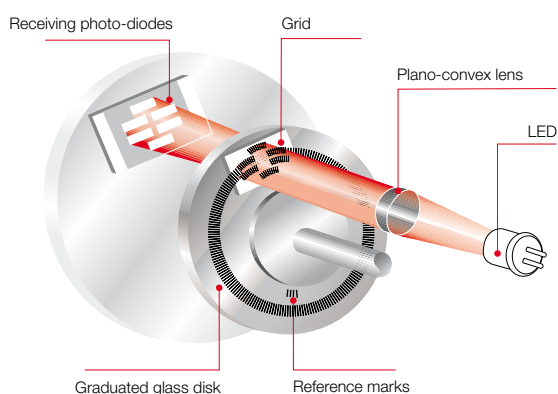

Angular encoder

Incremental

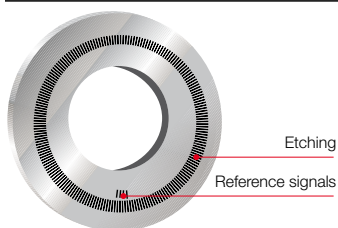

Distance-coded

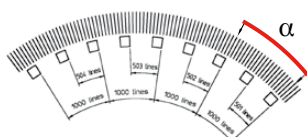

Reference signals (I_0)

It is a reference signal etched on a graduation and when scanned by the measuring system generates a pulse. Reference marks are used to validate and restore the machine zero position specially after turning on the machine power.

Fagor Automation encoders have three types of reference marks I_0 :

- **Incremental:** The reference signal obtained is synchronized with the feedback signals to ensure perfect measuring repeatability.
- **Distance-coded:** Both on linear and angular encoders each distance coded reference signal is graduated in a non linear way based on the predefined mathematical function. The machine position value can be restored by moving through two consecutive reference signals. The machine movement needed to know the real position is always very small and this is a very useful feature for large travel machines.

Series	Nr. of lines	Nr. of references	Angle α
H2-D90	18000	36	20°
S2-D90			
S2-D170			
H2-D200	36000	72	10°
H2-D200			

Electrical output signals

Differential TTL

These are complementary signals in compliance with the EIA standard RS-422. This characteristic together with a line termination of 120 Ω, twisted pair, and an overall shield provide greater immunity to electromagnetic noise caused by their environment.

Characteristics

Signals	A, /A, B, /B, I ₀ , / I ₀
Signal level	V _H ≥ 2.5V I _H = 20 mA V _L ≤ 0.5V I _L = 20 mA With 1 m cable
90° reference signal (I ₀)	Synchronized with A and B
Switching time	t ₊ /t ₋ < 30 ns With 1 m cable
Supply voltage and consumption	5 V ± 5%, 100 mA
T period	0.02°, 0.01°, 0.004°, 0.002°, 0.001°
Max. cable length	50 meters
Load impedance	Z ₀ = 120 Ω between differential

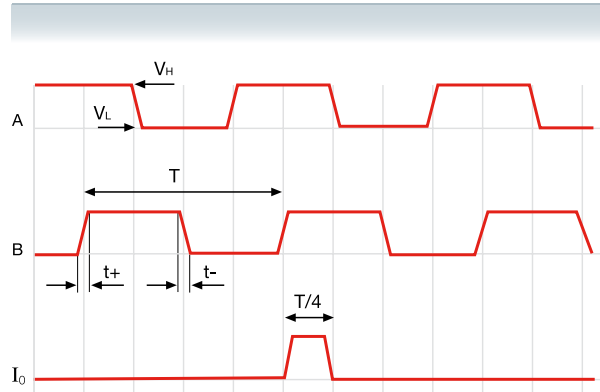

Voltage drop across cable

The voltage required for a TTL encoder must be 5V ± 5%. A simple formula may be used to calculate the maximum cable length depending on the section of the supply cables.

$$L_{max} = (V_{CC} - 4.5) * 500 / (Z_{CABLE/Km} * I_{MAX})$$

Example

V_{CC} = 5V, I_{MAX}=0.2 Amp (With 120 Ω load)

Z (1 mm ²)	=	16.6 Ω/Km	(L_{max}= 75 m)
Z (0.5 mm ²)	=	32 Ω/Km	(L_{max}= 39 m)
Z (0.25 mm ²)	=	66 Ω/Km	(L_{max}=19 m)
Z (0.14 mm ²)	=	132 Ω/Km	(L_{max}= 9 m)
Z (0.09 mm ²)	=	232 Ω/Km	(L_{max}= 5 m)

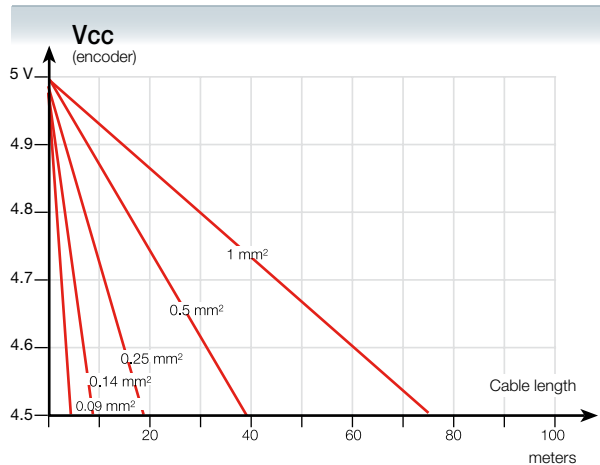

Differential 1 Vpp

They are complementary sinusoidal signals whose differential value is 1 Vpp centered on $V_{CC/2}$. This characteristic together with a line termination of 120Ω , twisted pair, and an overall shield provide greater immunity to electromagnetic noise caused by their environment.

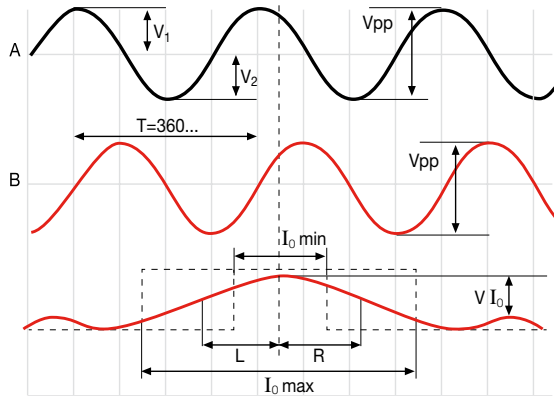

Characteristics

Signals	A, /A, B, /B, I ₀ / I ₀
V _{App}	1 V +20%, -40%
V _{Bpp}	1 V +20%, -40%
DC offset	2.5 V ± 0.5 V
Signal period	0.02°, 0.01°
Supply V	5 V ± 10%
Max. cable length	150 meters
A, B centered: $[V_1 - V_2] / 2 V_{pp}$	≤ 0.065
A&B relationship: V_{App} / V_{Bpp}	0.8 ÷ 1.25
A&B phase shift:	90° ± 10°
I ₀ amplitude: V _{I₀}	0.2 ÷ 0.8 V
I ₀ width: L + R	I _{0_min} : 180° I _{0_typ} : 360° I _{0_max} : 540°
I ₀ synchronism: L, R	180° ± 90°

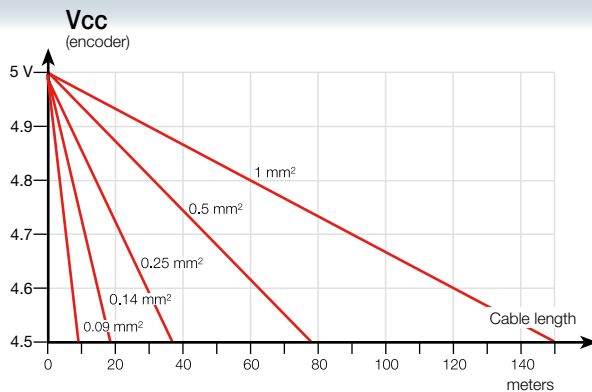

Voltage drop across cable

The voltage required for a 1 Vpp encoder must be $5 V \pm 10\%$. A simple formula may be used to calculate the maximum cable length depending on the section of the supply cables:

$$L_{max} = (V_{CC} - 4.5) \cdot 500 / (Z_{CABLE/Km} \cdot I_{MAX})$$

Example

V_{CC} = 5V, I_{MAX} = 0.1 Amp

Z (1 mm ²)	=	16.6 Ω/Km	(L _{max} = 150 m)
Z (0.5 mm ²)	=	32 Ω/Km	(L _{max} = 78 m)
Z (0.25 mm ²)	=	66 Ω/Km	(L _{max} = 37 m)
Z (0.14 mm ²)	=	132 Ω/Km	(L _{max} = 18 m)
Z (0.09 mm ²)	=	232 Ω/Km	(L _{max} = 10 m)

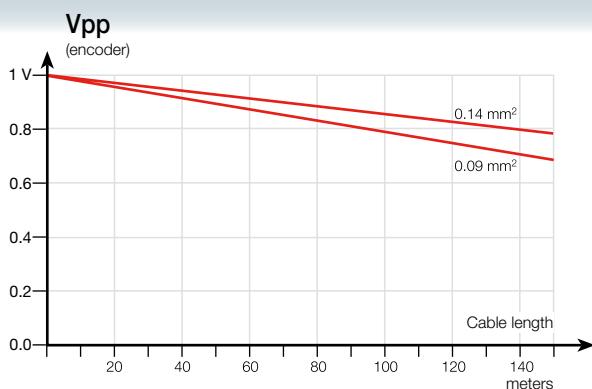

1 Vpp signal damping due to the cable section

Besides attenuation due to signal frequency, there is another signal attenuation caused by the section of the cable connected to the encoder.

H2-D200 series



Characteristics

	H2-18000	H2-36000	H2-90000
Measurement	By means of graduated glass disk		
Accuracy	± 2 arc-seconds		
Output signals	□□ TTL differential	□□ TTL differential	□□ TTL differential
Number of pulses/turn	18000 pulses/turn	36000 pulses/turn	90000 pulses/turn
Maximum frequency	200 KHz	200 KHz	1 MHz
Maximum electrical speed	< 666 min ⁻¹	< 333 min ⁻¹	< 666 min ⁻¹
Natural frequency	> 1000 Hz		
Supply	5 V ± 5%; < 150 mA (without load)	5 V ± 5%; < 150 mA (without load)	5 V ± 5%; < 150 mA (without load)
Maximum cable length	50 m	50 m	50 m
Maximum mechanical speed	1000 min ⁻¹ non-mechanical fault exclusion		
Inertia	10 ⁻³ kgm ²		
Starting torque	< 0.5 Nm		
Vibration	100 m/s ² (55...2000 Hz) IEC 60068-2-6		
Shock	1000 m/s ² (6 ms) IEC 60068-2-27		
Reference signal I ₀	One reference signal per encoder turn or distance-coded I ₀		
Operating temperature	0 °C...50 °C		
Storage temperature (in its packaging)	-20 °C...60 °C		
Weight	3.2 kg		
Protection	IP 64 DIN 40050 (standard) > IP 64 (DIN 40050) using pressurized air at 0.8 ± 0.2 bar in angular encoders (1)		
Connection	With built-in connector		

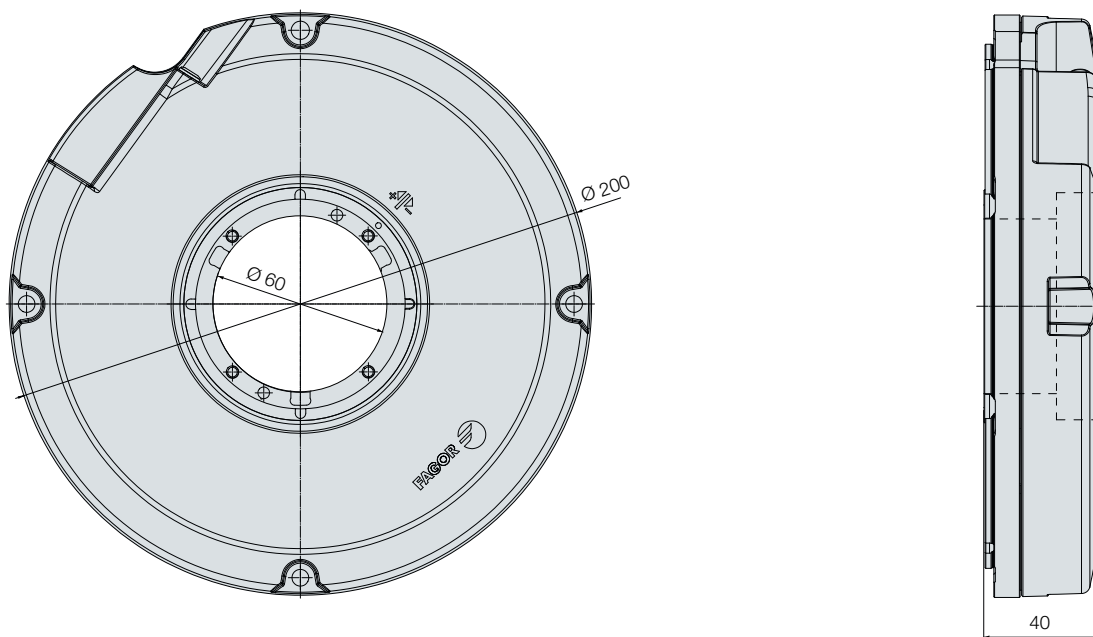

Additional information can be found in the technical documentation and installation manual available on the website www.fagorautomation.com

Order identification

Example of Angular Encoder: **H2OP-18000-D200-2**

H2	O	P	18000	D200	2
Type of shaft: • H2: Hollow shaft	Type of reference mark I₀: • Blank space: Incremental, one per revolution • O: Distance-coded marks	Type of signal: • Blank space: Differential TTL • P: 1 Vpp sinusoidal	Number of pulses/turn of the first feedback: • 18000: on 1 Vpp and TTL models • 36000: on 1 Vpp and TTL models • 90000: only on TTL models • 180000: only on TTL models • 360000: sonly on TTL models	Outside diameter: • D200: 200 mm	Accuracy: • 1: ±1 arc-second (only on 1 Vpp models) • 2: ±2 arc-seconds

H2-180000	H2-360000	H2P-18000	H2P-36000
By means of graduated glass disk			
± 2 arc-seconds		± 1 arc-second ± 2 arc-seconds	
□ □ TTL differential	□ □ TTL differential	~ 1 Vpp	~ 1 Vpp
180000 pulses/turn	360000 pulses/turn	18000 pulses/turn	36000 pulses/turn
1 MHz	1 MHz	180 kHz	180 kHz
< 333 min ⁻¹	< 166 min ⁻¹	< 600 min ⁻¹	< 300 min ⁻¹
> 1000 Hz			
5 V ± 5%; < 150 mA (without load)	5 V ± 5%; < 150 mA (without load)	5 V ± 10%; < 150 mA (without load)	5 V ± 10%; < 150 mA (without load)
50 m	50 m	150 m	150 m
1000 min ⁻¹ non-mechanical fault exclusion			
10 ⁻³ kgm ²			
< 0.5 Nm			
100 m/s ² (55...2000 Hz) IEC 60068-2-6			
1000 m/s ² (6 ms) IEC 60068-2-27			
One reference signal per encoder turn or distance-coded I ₀			
0 °C...50 °C			
-20 °C...60 °C			
3.2 kg			
IP 64 DIN 40050 (standard)			
> IP 64 (DIN 40050) using pressurized air at 0.8 ± 0.2 bar in angular encoders (1)			
With built-in connector			

(1) For more information consult the AI-1000 Filter Unit catalog.

H2-D90 series



Characteristics

	H2-18000	H2-36000	H2-90000	H2-180000	H2P-18000
Measurement	By means of graduated glass disk				
Accuracy	±2.5 arc-seconds ±5 arc-seconds				
Output signals	□□ TTL differential	□□ TTL differential	□□ TTL differential	□□ TTL differential	~ 1 Vpp
Number of pulses/turn	18000 pulses/turn	36000 pulses/turn	90000 pulses/turn	180000 pulses/turn	18000 pulses/turn
Maximum frequency	200 KHz	400 KHz	1 MHz	1 MHz	180 kHz
Maximum electrical speed	< 666 min ⁻¹	< 666 min ⁻¹	< 666 min ⁻¹	< 333 min ⁻¹	< 600 min ⁻¹
Natural frequency	> 1000 Hz				
Supply	5 V ± 5%; < 150 mA (without load)	5 V ± 5%; < 150 mA (without load)	5 V ± 5%; < 150 mA (without load)	5 V ± 5%; < 150 mA (without load)	5 V ± 10%; < 150 mA (without load)
Maximum cable length	50 m	50 m	50 m	50 m	150 m
Maximum mechanical speed	3000 min ⁻¹ non-mechanical fault exclusion				
Inertia	65 · 10 ⁻⁶ kgm ²				
Starting torque	< 0.08 Nm				
Vibration	100 m/s ² (55...2000 Hz) IEC 60068-2-6				
Shock	1000 m/s ² (6 ms) IEC 60068-2-27				
Reference signal I ₀	One reference signal per encoder turn or distance-coded I ₀				
Operating temperature	-20 °C...70 °C (5"); 0 °C...50 °C (2.5")				
Storage temperature (in its packaging)	-20 °C...60 °C				
Weight	1 kg				
Protection	IP 64 DIN 40050 (standard) > IP 64 (DIN 40050) using pressurized air at 0.8 ± 0.2 bar in angular encoders (1)				
Connection	With built-in connector				

(1) For more information consult the AI-1000 Filter Unit catalog.

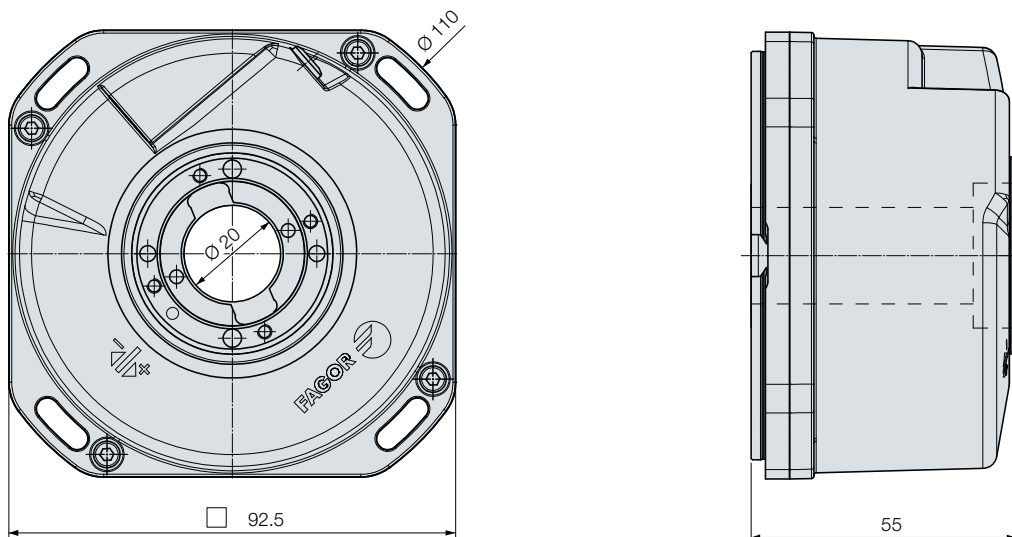

■ Additional information can be found in the technical documentation and installation manual available on the website www.fagorautomation.com

Order identification

Example of Angular Encoder: **H2OP-18000-D90-2**

H2	O	P	18000	D90	2
Type of shaft: • H2: Hollow shaft	Type of reference mark I₀: • Blank space: Incremental, one per revolution • O: Distance-coded marks	Type of signal: • Blank space: Differential TTL • P: 1 Vpp sinusoidal	Number of pulses/turn of the first feedback: • 18000: on 1 Vpp and TTL models • 36000: only on TTL models • 90000: only on TTL models • 180000: only on TTL models	Outside diameter: • D90: 90 mm	Accuracy: • 2: ± 2.5 arc-seconds • 5: ± 5 arc-seconds

S2-D170 series



Characteristics

	S2-18000	S2-90000	S2-180000	S2P-18000
Measurement	By means of graduated glass disk			
Accuracy	±2 arc-seconds			
Output signals	□□ TTL differential	□□ TTL differential	□□ TTL differential	~ 1 Vpp
Number of pulses/turn	18000 pulses/turn	90000 pulses/turn	180000 pulses/turn	18000 pulses/turn
Maximum frequency	200 KHz	1 MHz	1 MHz	180 kHz
Maximum electrical speed	< 666 min ⁻¹	< 666 min ⁻¹	< 333 min ⁻¹	< 600 min ⁻¹
Supply	5 V ± 5%; < 150 mA (without load)	5 V ± 5%; < 150 mA (without load)	5 V ± 5%; < 150 mA (without load)	5 V ± 10%; < 150 mA (without load)
Maximum cable length	50 m	50 m	50 m	150 m
Maximum mechanical speed	3000 min ⁻¹			
Inertia	35 · 10 ⁻⁶ kgm ²			
Starting torque	< 0.01 Nm			
Load of shaft	Axial: 1 kg Radial: 1 kg			
Vibration	100 m/s ² (55...2000 Hz) IEC 60068-2-6			
Shock	1000 m/s ² (6 ms) IEC 60068-2-27			
Reference signal I ₀	One reference signal per encoder turn or distance-coded I ₀			
Operating temperature	0 °C...50 °C			
Storage temperature (in its packaging)	-20 °C...60 °C			
Weight	2.65 kg			
Protection	IP 64 DIN 40050 (standard) > IP 64 (DIN 40050) using pressurized air at 0.8 ±0.2 bar in angular encoders (1)			
Connection	With built-in connector			

(1) For more information consult the AI-1000 Filter Unit catalog.

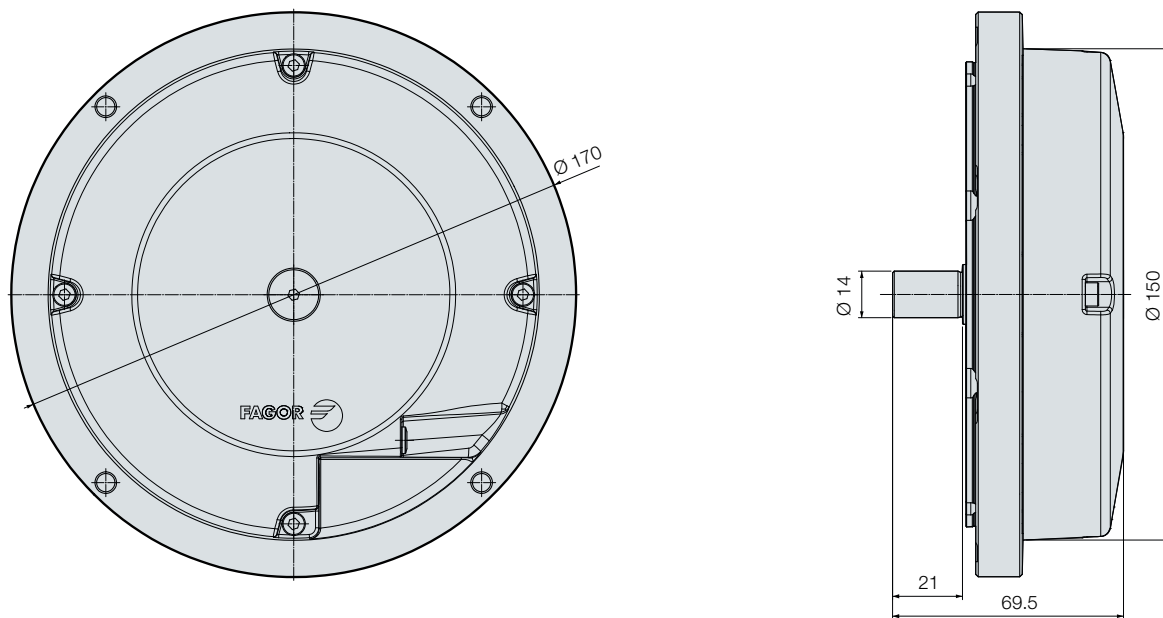

■ Additional information can be found in the technical documentation and installation manual available on the website www.fagorautomation.com

Order identification

Example of Angular Encoder: **S20P-18000-D170-2**

S2	O	P	18000	D170	2
Type of shaft: • S2: Solid shaft	Type of reference mark I₀: • Blank space: Incremental, one per revolution • O: Distance-coded marks	Type of signal: • Blank space: Differential TTL • P: 1 Vpp sinusoidal	Number of pulses/turn of the first feedback: • 18000: on 1 Vpp and TTL models • 90000: only on TTL models • 180000: only on TTL models	Outside diameter: • D170: 170 mm	Accuracy: • 2: ±2 arc-seconds

S2-D90 series



Characteristics

	S2-18000	S2-36000	S2-90000	S2-180000	S2P-18000
Measurement	By means of graduated glass disk				
Accuracy	±2.5 arc-seconds ±5 arc-seconds				
Output signals	□□ TTL differential	□□ TTL differential	□□ TTL differential	□□ TTL differential	~ 1 Vpp
Number of pulses/turn	18000 pulses/turn	36000 pulses/turn	90000 pulses/turn	180000 pulses/turn	18000 pulses/turn
Maximum frequency	200 KHz	400 KHz	1 MHz	1 MHz	180 kHz
Maximum electrical speed	< 666 min ⁻¹	< 666 min ⁻¹	< 666 min ⁻¹	< 333 min ⁻¹	< 600 min ⁻¹
Supply	5 V ± 5%; < 150 mA (without load)	5 V ± 5%; < 150 mA (without load)	5 V ± 5%; < 150 mA (without load)	5 V ± 5%; < 150 mA (without load)	5 V ± 10%; < 150 mA (without load)
Maximum cable length	50 m	50 m	50 m	50 m	150 m
Maximum mechanical speed	10 000 min ⁻¹				
Inertia	25 · 10 ⁻⁶ kgm ²				
Starting torque	< 0.01 Nm				
Load of shaft	Axial: 1 kg Radial: 1 kg				
Vibration	100 m/s ² (55...2000 Hz) IEC 60068-2-6				
Shock	1000 m/s ² (6 ms) IEC 60068-2-27				
Reference signal I₀	One reference signal per encoder turn or distance-coded I ₀				
Operating temperature	-20 °C...70 °C (5"); 0 °C...50 °C (2.5")				
Storage temperature (in its packaging)	-20 °C...60 °C				
Weight	0.8 kg				
Protection	IP 64 DIN 40050 (standard) > IP 64 (DIN 40050) using pressurized air at 0.8 ±0.2 bar in angular encoders (1)				
Connection	With built-in connector				

(1) For more information consult the AI-1000 Filter Unit catalog.

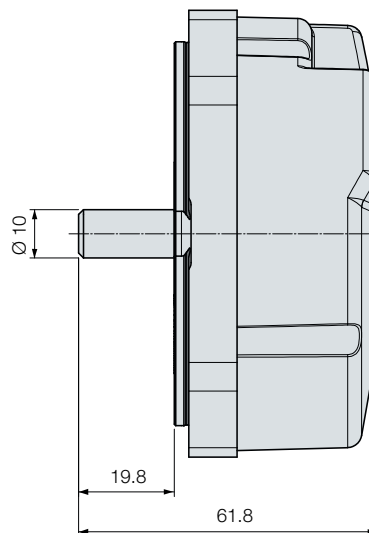
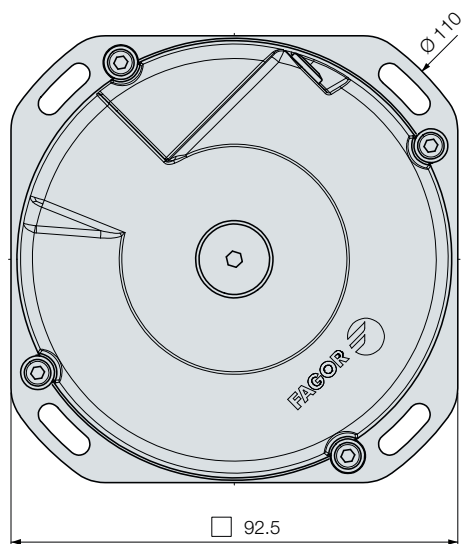

Additional information can be found in the technical documentation and installation manual available on the website www.fagorautomation.com

Order identification

Example of Angular Encoder: **S2OP-18000-D90-2**

S2	O	P	18000	D90	2
Type of shaft: • S2: Solid shaft	Type of reference mark I_Q: • Blank space: Incremental, one per revolution • O: Distance-coded marks	Type of signal: • Blank space: Differential TTL • P: 1 Vpp sinusoidal	Number of pulses/turn of the first feedback: • 18000: on 1 Vpp and TTL models • 36000: only on TTL models • 90000: only on TTL models • 180000: only on TTL models	Outside diameter: • D90: 90 mm	Accuracy: • 2: ±2.5 arc-seconds • 5: ±5 arc-seconds

H, S series



General characteristics

	S	SP	H	HP	HA
Measurement	Up to 625 pulses/turn: By means of perforated metallic disk From 625 pulses/turn on: By means of graduated glass disk				
Accuracy	± 1/10 of the pitch				
Maximum speed	12000 rpm				6000 rpm
Vibration	100 m/seg ² (10 ÷ 2000 Hz)				
Shock	300 m/seg ² (11 m/seg)				
Inertia	1.6 · 10 ⁻⁶ kgm ²				3 · 10 ⁻⁶ kgm ²
Starting torque	0.003 Nm (30 gr/cm) max. at 20 °C				0.02 Nm (200 gr/cm)
Type of shaft	Solid shaft		Hollow shaft		Hollow shaft
Maximum load on the shaft	Axial: 10 N Radial: 20 N		-		-
Weight	0.3 kg				0.5 kg
Ambient characteristics:					
Running temperature	0 °C...+70 °C				
Storage temperature	-30 °C...+80 °C				
Relative humidity	98 % non-condensing				
Protection	IP 64 (DIN 40050). On S and SP models: Optional IP 66				IP 65
Light source	IRED (InfraRed Emitting Diode)				
Maximum frequency	200 kHz				300 kHz
Reference signal I₀	One reference signal per encoder turn				
Supply voltage	5 V ± 5% (TTL)	5 V ± 10% (1 Vpp)	5 V ± 5% (TTL)	5 V ± 10% (1 Vpp)	5 V ± 5% (TTL)
Consumption	70 mA typical, 100 mA max. (without load)				
Output signals	□ TTL differential	~ 1 Vpp	□ TTL differential	~ 1 Vpp	□ TTL differential
Maximum cable length	50 m	150 m	50 m	150 m	50 m

Number of pulses/turn

S	SP	H	HP	HA
100	-	100	-	-
200	-	200	-	-
250	-	250	-	-
400	-	400	-	-
500	-	500	-	-
600	-	600	-	-
635	-	635	-	-
1000	1000	1000	1000	-
1024	1024	1024	1024	1024
1250	1250	1250	1250	1800
1270	1270	1270	1270	2000
1500	1500	1500	1500	2048
2000	2000	2000	2000	2500
2500	2500	2500	2500	3000
3000	3000	3000	3000	3600
-	3600	-	-	4000
-	4320	-	-	4096
5000	5000	5000	5000	5000
-	-	-	-	10000

S, SP models

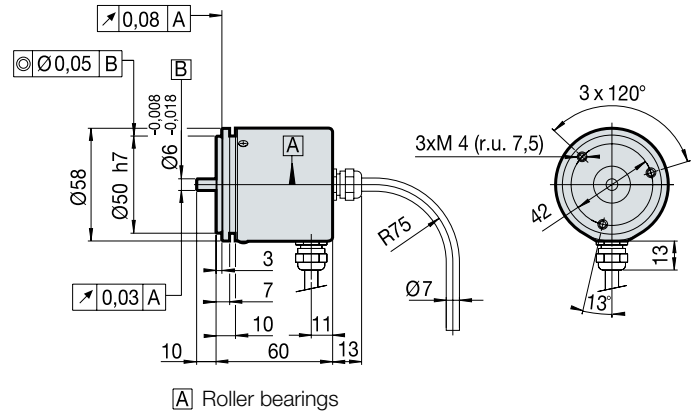

H, HP models



L: Min. 9 mm, max. 16 mm

$\textcircled{\text{O}} D$ g7 mm
3
4
6
6.35
7
8
9.53
10

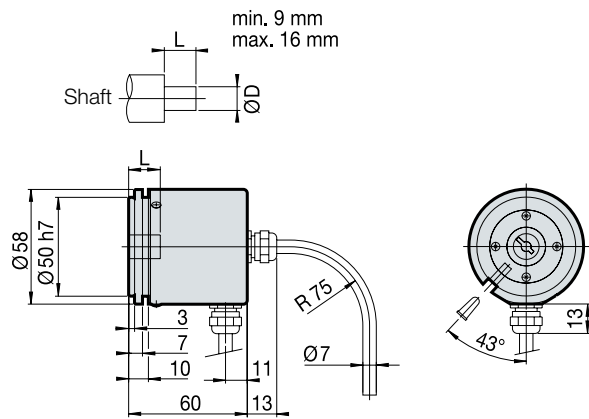

HA model

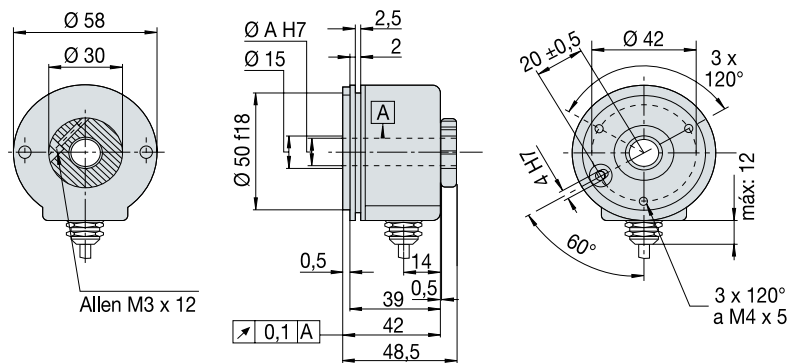

Note: more detailed information on the installation in the manual

Order identification - models H, HP, S and SP

Example for a Rotary Encoder: **SP-1024-R-C5-IP 66**

S	P	1024	R	C5	IP 66
Model: • S: Solid shaft • H: Hollow shaft	Type of signal: • Blank space: square signal (TTL or HTL) • P: 1 Vpp sinusoidal signal	Number of pulses/turn (See table page 44)	Cable exit (not needed for C type of connector, it can be only radial): • R: Radial • Blank space: Axial	Type of connector: • Blank space: 1 m cable without connector • C: Flange socket CONNEI 12 • C5: 1 m cable with CONNEI 12 connector	Protection: • Blank space: Standard protection (IP 64) • Protection IP 66 (only S model)

Order identification - HA model

Example for a Rotary Encoder: **HA - 22132 - 250**

HA	2	2	1	3	2	2500
Model: • H: Hollow shaft	Type of clamp: • 1: Rear clamp • 2: Front clamp	Size of the hollow shaft ($\textcircled{\text{O}} A$): • 2: 12 mm	Output signals: • 1: A, B, I_0 plus their inverted	Type of connection: • 3: Radial cable (1 m) with CONNEI 12 connector	Supply voltage: • 2: RS-422 (5 V)	Number of pulses/turn (See table page 44)

direct connection cables

Connection to FAGOR CNC

UP TO 12 METERS

For direct connection to FAGOR AXD

EC-...P-D

Lengths: 1, 3, 6, 9 and 12 meters

SUB D 15 HD connector (male Pin )

Pin	Signal	Color
1	A	Green
2	/A	Yellow
3	B	Blue
4	/B	Red
5	I ₀	Grey
6	/I ₀	Pink
9	+5 V	Brown
11	0 V	White
15	Ground	Shield
Housing	Ground	Shield

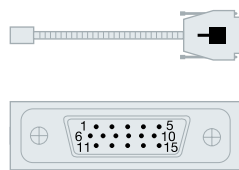

For direct connection to FAGOR QUERCUS

EC-...P-QD

Lengths: 1, 3, 6, 9 and 12 meters

SUB D 15 HD connector (male Pin )

Pin	Signal	Color
1	A	Green
2	/A	Yellow
3	B	Blue
4	/B	Red
5	I ₀	Grey
6	/I ₀	Pink
9	+5 V	Brown
11	0 V	White
Housing	Ground	Shield

FROM 12 METERS ON

Cable EC-...A-C1 + alargadera XC-C2-...-D

EC-...A-C1 / EC-...A-C5

Lengths: 1 and 3 meters

M23 12 connector (male Pin )

Pin	Signal	Color
5	A	Green
6	/A	Yellow
8	B	Blue
1	/B	Red
3	I ₀	Grey
4	/I ₀	Pink
7	/Alarm	Purple
12	+5 V	Brown
2	+5 V sensor	
10	0 V	White
11	0 V sensor	
Housing	Ground	Shield

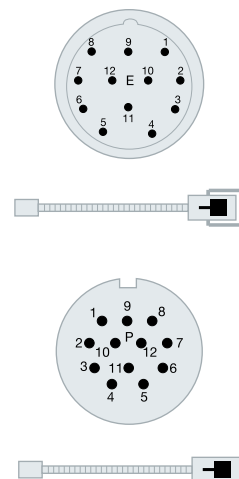

XC-C2-...-D extension cable

Lengths: 5, 10, 15, 20 and 25 meters

M23 12 connector (female Pin )

SUB D 15 HD connector (male Pin )

Pin	Pin	Signal	Color
5	1	A	Brown
6	2	/A	Green
8	3	B	Grey
1	4	/B	Pink
3	5	I ₀	Red
4	6	/I ₀	Black
7	8	/Alarm	Purple
12	9	5 V	Brown/ Green
2	9	+5 V sensor	Blue
10	11	0 V	White/ Green
11	11	0 V sensor	White
Housing	Housing	Ground	Shield

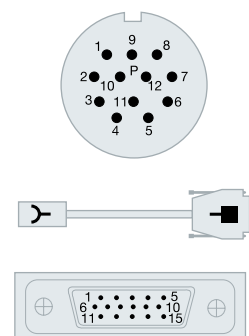

Connection to other CNC's

UP TO 12 METERS

For direct connection to FANUC® (second feedback)

EC-...C-FN1

Lengths: 1, 3, 6, 9 and 12 meters

HONDA / HIROSE connector (female Pin )

Pin	Signal	Color
1	A	Green
2	/A	Yellow
3	B	Blue
4	/B	Red
5	I ₀	Grey
6	/I ₀	Pink
9	+5 V	Brown
18-20	+5 V sensor	
12	0 V	White
14	0 V sensor	
16	Ground	Internal shield
Housing	Ground	External shield

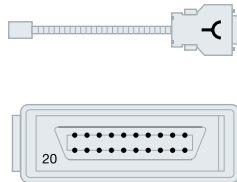

For direct connection to SIEMENS® (Solution Line and Sinumerik One).

SME20 (1 Vpp only)

EC-...A-C5

SMC20 (1 Vpp only)

EC-...P-S3

Lengths: 1, 3, 6, 9 and 12 meters

SUB D25 connector (female Pin )

Pin	Signal	Color
3	A	Green
4	/A	Yellow
6	B	Blue
7	/B	Red
17	I ₀	Grey
18	/I ₀	Pink
1	+5 V	Brown
14	+5 V sensor	
2	0 V	White
16	0 V sensor	
Housing	Ground	Shield

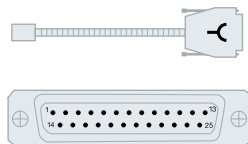

SMC30 (differential TTL only)

EC-...P-S2

Lengths: 1, 3, 6, 9 and 12 meters

SUB D 15 connector (male Pin )

Pin	Signal	Color
15	A	Green
14	/A	Yellow
13	B	Blue
12	/B	Red
10	I ₀	Grey
11	/I ₀	Pink
4	+5 V	Brown
5	+5 V	
7	0 V	White
Housing	Ground	Shield

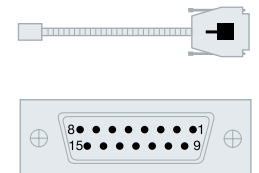

Without a connector at one end; for other applications.

EC-...AS-O

Lengths: 1, 3, 6, 9 and 12 meters

Signal	Color
A	Green
/A	Yellow
B	Blue
/B	Red
I ₀	Grey
/I ₀	Pink
+5 V	Brown
+5 V sensor	Purple
0 V	White
0 V sensor	Black
Ground	Shield



direct connection cables

Connection to other CNC's

FROM 12 METERS ON

- EC-...A-C1 cable + XC-C2-...-FN1 extension cable
- EC-...A-C5 cable + XC-C4-...-C5 extension cable (1 Vpp only)
- EC-...A-C5 cable + XC-C4-...-S3 extension cable (1 Vpp only)
- EC-...A-C5 cable + XC-C4-...-S2 extension cable (differential TTL only)

XC-C2-...-FN1 extension cable

Lengths: 5, 10, 15, 20 and 25 meters

M23 12 connector (female Pin )

HONDA / HIROSE connector (female Pin )

 Pin	 Pin	Signal	Color
5	1	A	Brown
6	2	/A	Green
8	3	B	Grey
1	4	/B	Pink
3	5	I ₀	Red
4	6	/I ₀	Black
12	9	+5 V	Brown/ Green
2	18-20	+5 V sensor	Blue
10	12	GND	White/ Green
11	14	GND sensor	White
Housing	16	Ground	Shield

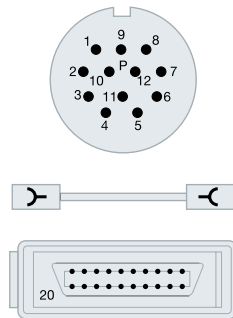

XC-C4-...-C5 extension cable

Lengths: 5, 10, 15, 20 and 25 meters

M23 12 connector (female Pin )

M23 12 connector (male Pin )

 Pin	 Pin	Signal	Color
5	5	A	Brown
6	6	/A	Green
8	8	B	Grey
1	1	/B	Pink
3	3	I ₀	Red
4	4	/I ₀	Black
12	12	+5 V	Brown/ Green
2	2	+5 V sensor	Blue
10	10	0 V	White/ Green
11	11	0 V sensor	White
7	7	/Alarm	Purple
Housing	Housing	Ground	Shield

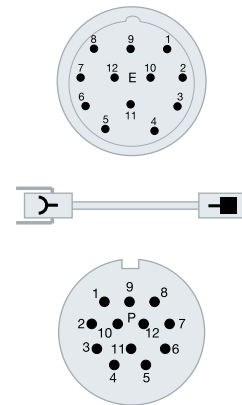

XC-C4-...-S3 extension cable

Lengths: 5, 10, 15, 20 and 25 meters

M23 12 connector (female Pin )

SUB D25 connector (female Pin )

 Pin	 Pin	Signal	Color
5	3	A	Brown
6	4	/A	Green
8	6	B	Grey
1	7	/B	Pink
3	17	I ₀	Red
4	18	/I ₀	Black
12	1	+5 V	Brown/ Green
2	14	+5 V sensor	Blue
10	2	0 V	White/ Green
11	16	0 V sensor	White
Housing	Housing	Ground	Shield

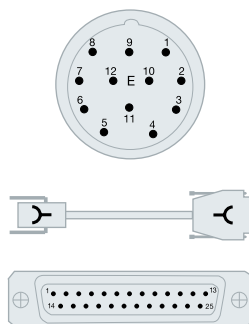

XC-C4-...-S2 extension cable

Lengths: 5, 10, 15, 20 and 25 meters

M23 12 connector (female Pin )

SUB D15 connector (male Pin )

 Pin	 Pin	Signal	Color
5	15	A	Brown
6	14	/A	Green
8	13	B	Grey
1	12	/B	Pink
3	10	I ₀	Red
4	11	/I ₀	Black
12	4	+5 V	Brown/ Green
	5	+5 V	
2	6	+5 V sensor	Blue
10	7	0 V	White/ Green
11	9	0 V sensor	White
Housing	Housing	Ground	Shield

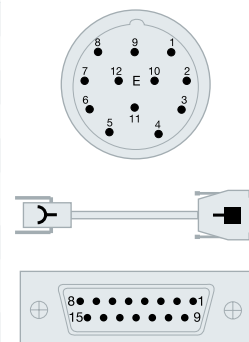

mechanical fault exclusion

Shaft coupling with nut and mechanical fault exclusion washer

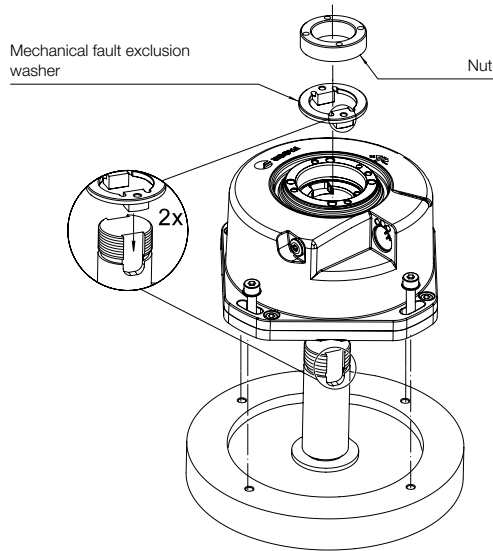

For the H2-D90, H2-D200 and H2-D200i100 angular encoders, a mechanical connection between the measuring system and the drive can be made, which excludes failures due to the possibility of loosening and undoing of the connection. To make a mechanical fault exclusion connection, it is essential that the assembly be made by either using an additional washer (mechanical fault exclusion washer) or alternatively with additional elastic pins.

It must also be taken into account that there are limitations with the following aspects:

- The materials used: it is essential that the shaft of the machine and the fastening components are made of steel
- The maximum turning speed
- The operating temperature

Specific information is indicated in the product characteristics tables.

The part numbers and characteristics for the various models of mechanical fault exclusion washer and nut are:

Model	Washer code	Nut code	Moment of Inertia Nut and washer
H2-D90	82620140	82620150	$4.8 \cdot 10^{-6} \text{ kgm}^2$
H2-D200 (Ø 60 mm)	82620141	82620151	$87 \cdot 10^{-6} \text{ kgm}^2$
H2-D200i100	82620142	82620152	$550 \cdot 10^{-6} \text{ kgm}^2$

Front end shaft coupling with pins

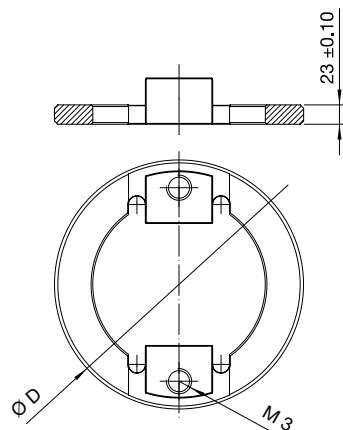
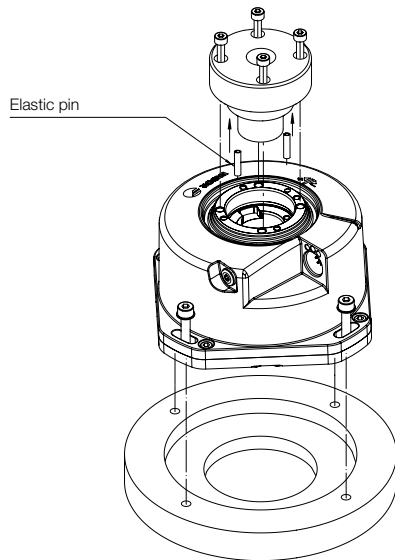

Model	Diameter Ø (mm)
H2-D90	29,6
H2-D200 (Ø 60 mm)	70
H2-D200i100	114

Drawings representing the hollow shaft angular encoder of 90 mm diameter (H2-D90).

ANGULAR ENCODERS accessories

Couplings for solid-shaft encoders

In order to ensure the accuracy of the solid-shaft angular encoder, it is a must to use couplings that provide them with long lasting stability. Fagor Automation recommends using our AA and AP couplings that have been designed for our encoders and provide a guarantee that other couplings cannot.

The selection of the coupling model depends on the encoder, the available space and the required characteristics.

AA Model

The AA model comes in three versions depending on the diameter of the coupling as shown in the table below:

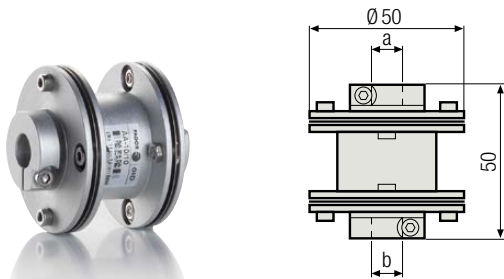

Model	a mm	b mm
AA 10/10	10	10
AA 10/14	10	14
AA 14/14	14	14

AP model

The AP model comprise two versions for different shaft diameters.

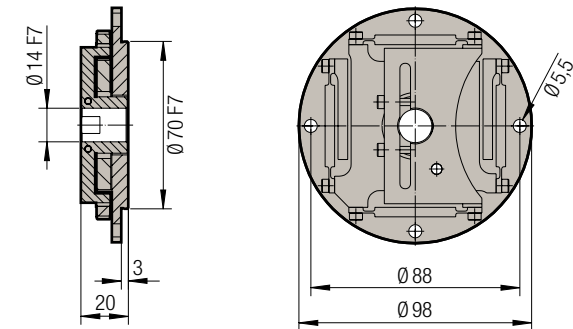

AP 14 model

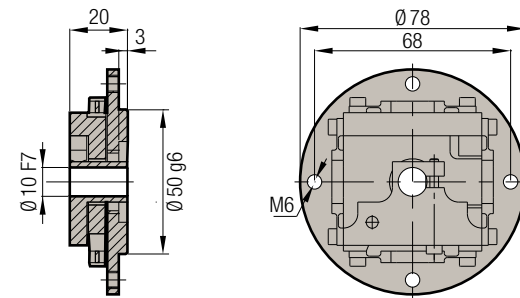

AP 10 model



Specific characteristics

	AA 10/10 AA 10/14 AA 14/14	AP 10	AP 14
Maximum radial misalignment permitted 	0.3 mm	0.3 mm	0.3 mm
Maximum angular misalignment permitted 	0.5°	0.5°	0.2°
Maximum axial misalignment permitted 	0.2 mm	0.2 mm	0.1 mm
Kinematic transfer error	± 2" if $\lambda \leq 0.1$ mm and $\alpha \leq 0.09^\circ$	± 3" if $\lambda \leq 0.1$ mm and $\alpha \leq 0.09^\circ$	± 2" if $\lambda \leq 0.1$ mm and $\alpha \leq 0.09^\circ$
Maximum torque that may be transmitted	0.2 Nm	0.5 Nm	0.5 Nm
Torsion rigidity	1,500 Nm/rad.	1,400 Nm/rad.	6,000 Nm/rad.
Maximum rotating speed	10,000 rpm	1,000 rpm	1,000 rpm
Weight	93 gr	128 gr	222 gr
Inertia	20×10^{-6} kgm ²	100×10^{-6} kgm ²	200×10^{-6} kgm ²

ROTARY ENCODERS

accessories

Coupling caps (solid shaft)

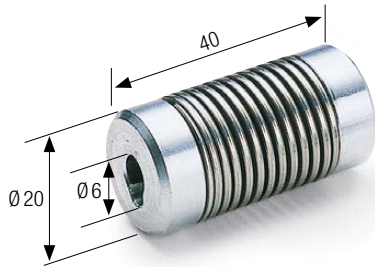

AF model

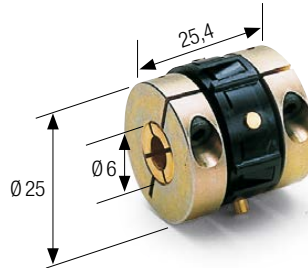

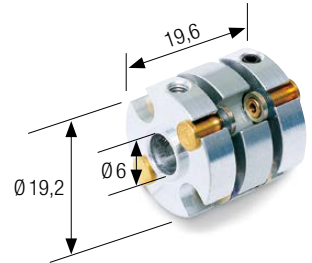

AC model



AL model

Specific characteristics

	AF	AC	AL
Maximum radial misalignment permitted 	2 mm	1 mm	0.2 mm
Maximum angular misalignment permitted 	8°	5°	4°
Maximum axial misalignment permitted 	± 1.5 mm	—	± 0.2 mm
Maximum torque that may be transmitted	2 Nm	1.7 Nm	0.9 Nm
Torsion rigidity	1.7 Nm/rad.	50 Nm/rad.	150 Nm/rad.
Maximum rotating speed	12,000 rpm		

AH coupling caps

Rotary encoders: coupling caps (hollow shaft)

The hollow shaft encoders are accompanied by a standard 6 mm cap diameter (Ø 6).

Can also be supplied in the following diameters: Ø 3, Ø 4, Ø 6, Ø 7, Ø 8 and Ø 10 mm, 1/4" and 3/8".



AD-M washer

Washer for mounting rotary encoder models H, HP, S, SP.

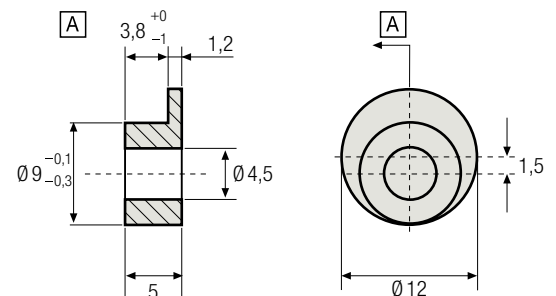

FeeDat® is a registered trademark of Fagor Automation,
 DRIVE-CLIQ® is a registered trademark of SIEMENS® Aktiengesellschaft,
 SIEMENS® is a registered trademark of SIEMENS® Aktiengesellschaft,
 FANUC® is a registered trademark of FANUC® Ltd.,
 MITSUBISHI® is a registered trademark of MITSUBISHI® Shoji Kaisha, Ltd.,
 PANASONIC® is a registered trademark of PANASONIC® Corporation,
 BISS® is a registered trademark of IC-Haus GmbH, and
 VITON® is a registered trademark of E. I. du Pont de Nemours and Company.

Other languages are available in the Downloads section from Fagor Automation's website.

Fagor Automation shall not be held responsible for any printing or transcribing errors in the catalog and reserves the right to make any changes to the characteristics of its products without prior notice.



Fagor Automation holds the ISO 9001 Quality System Certificate and the CE Certificate for all products manufactured.



Fagor Automation, S. Coop.
 B° San Andrés, 19
 E-20500 Arrasate - Mondragón
 SPAIN
 Tel.: +34 943 039 800
 Fax: +34 943 791 712
 E-mail: contact@fagorautomation.es

www.fagorautomation.com

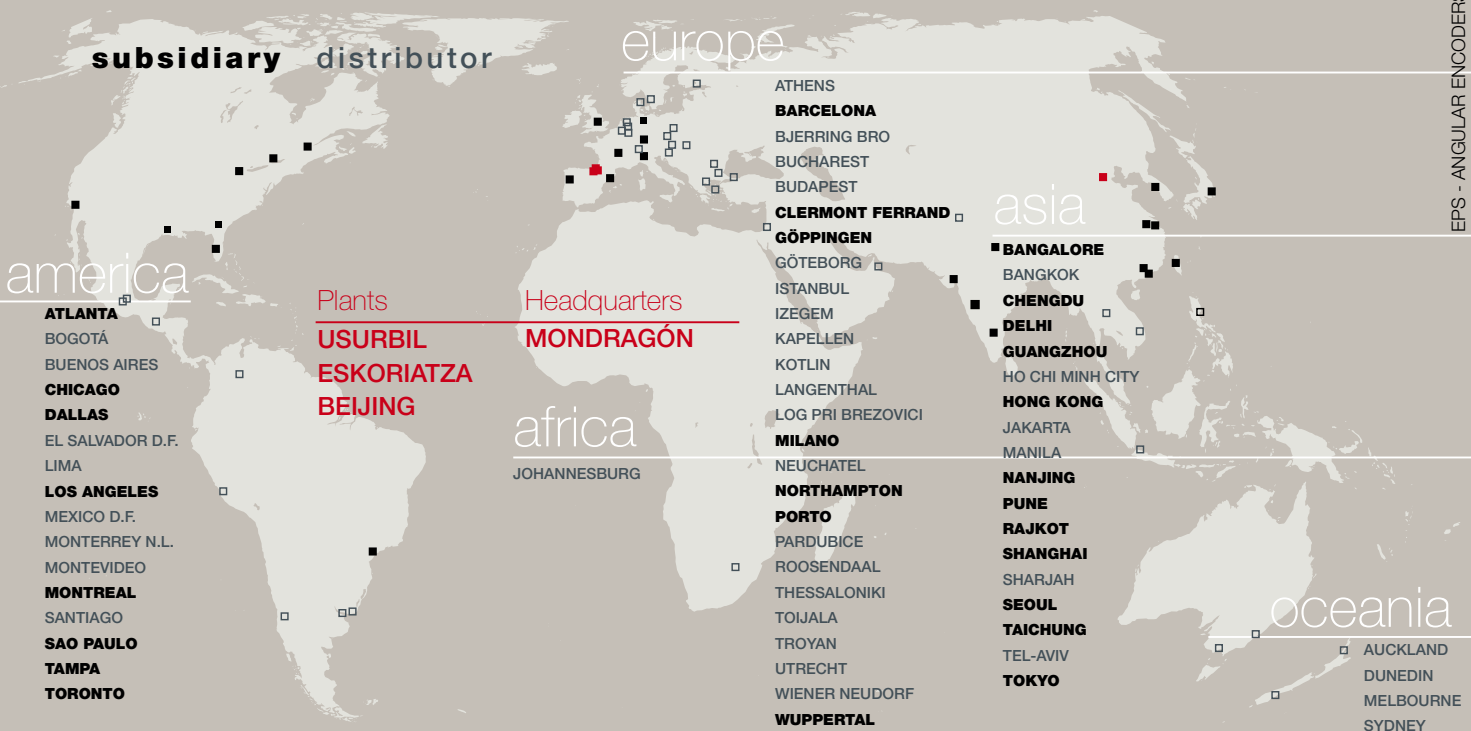

worldwide automation